

# 4" to 18" Sentry Series Turbine Meters

Specification SS02001 Issue/Rev. 1.8 (11/25)



## Smith Meter® Turbine Meters

The Smith Meter Sentry Series Turbine Meters are rimmed, rotor-type meters with helical blades. These meters use both an upstream and downstream stator and have tungsten carbide bearings with a hydrodynamic thrust balance system. They provide highly accurate measurements required for custody transfer of petroleum liquids, such as crude oil and refined products, in larger pipelines.

The model specifications provided in this document is the Sentry Series 4 inch (") to 18" turbine meter.

**NOTE:** Different features and requirements are available based on where the meter is manufactured. Throughout this document, manufacturing locations are denoted with either Erie, Pennsylvania, USA, or Ellerbek, Germany. Orders must be placed with the noted location to receive a unit with the specific feature.

## Features

- Rimmed rotor for durability and high resolution pulse output
- Helical blades for a streamlined flow pattern that is less susceptible to cavitation
- All stainless-steel, wetted parts for corrosion-free service
- Tungsten carbide bearings that provide long life on low-lubricity liquids
- Hydrodynamic thrust balance system, which minimizes friction and wear on thrust bearings and facilitates long service life and high accuracy

## Options

- Bidirectional flow, which enables the meter to accurately register flow in either direction
- Multiple pickup coils, used when direction sensing or pulse security is required; a third pickup coil is available to drive auxiliary equipment, such as a back-up counter or prover
- $\pm 0.10$  percent (%) and  $\pm 0.07\%$  linearity available
- For a high resolution (HR) option, the K-factor will be 1.5x the nominal for the 4" meter and 2x the nominal for the 6", 6" LF, and 8" meters.
- National Association of Corrosion Engineers (NACE) compliance to MR0175/ISO 15156-1
- Turbine meter diagnostics (available when used with AccuLERT; refer to AccuLERT specifications ([SS02015](#)))
- PA-6 preamplifiers

## Operating Specifications

### Materials of Construction

Body	316 series stainless steel
Flanges (Not Wetted)	Carbon steel Optional: 304 series stainless steel
Internals	300 series stainless steel, except 430 stainless steel rotor buttons
Bearings and Thrust Washers	Tungsten carbide

### Flow Range

Meter Sizes	Units	Normal Flow Range		Nominal K-Factor (Pulses/Unit) ±5%
		Minimum Rate	Maximum Rate	
4"	bph	150	1,500	2,100
	m <sup>3</sup> /h	24	240	13,210
6" low flow (LF)	bph	250	2,500	1,050
	m <sup>3</sup> /h	40	400	6,615
6"	bph	400	4,000	1,050
	m <sup>3</sup> /h	64	635	6,615
8"	bph	750	7,500	525
	m <sup>3</sup> /h	120	1,195	3,300
10"	bph	1,200	12,000	525
	m <sup>3</sup> /h	191	1,910	3,300
12"	bph	1,800	18,000	265
	m <sup>3</sup> /h	286	2,860	1,670
16"	bph	2,700	27,000	105
	m <sup>3</sup> /h	430	4,295	662
18"	bph	3,500	35,000	105
	m <sup>3</sup> /h	557	5,565	662

**NOTE:** Units are measured in barrels per hour (bph) and cubic meters per hour (m<sup>3</sup>h).

**NOTE:** Metric units are nominal and may not convert precisely.

**NOTE:** For bidirectional flow, the minimum flow rate is 20% of the normal maximum rate.

**NOTE:** For a high resolution (HR) option, the K-factor will be 1.5x the nominal for the 4" meter and 2x the nominal for the 6", 6" LF, and 8" meters.

### Linearity

- ±0.15% linearity over normal flow range
- ±0.10% linearity over 5.1 flow range
- ±0.07% linearity over 5.1 flow range

**NOTE:** Linearities and pressure drops are based on 0.82 specific gravity (SG), 1 millipascal-second (mPa·s) (1.5 centipoise (cP)) liquid.

### Repeatability

See repeatability information in the American Petroleum Institute (API) Manual of Petroleum Measurement Standards (MPMS) or International Organization of Legal Metrology (OIML) R-117-1.

### Overspeed

Overspeed is 130% of maximum flow rate for 5% duty cycle.

### End Connections

- Class 150, 300, 600, and 900 American Society of Mechanical Engineers (ASME) B16.5, 125-250 arithmetic average roughness height (AARH) finish raised-face (RF) flanges
- Consult factory for higher working pressure or other types of flanges

Maximum Working Pressure (pounds per square inch (psi) (kilopascal (kPa))		
ASME	Carbon-Steel Flange	Stainless-Steel Flange
150	285 (1,965)	275 (1,896)
300	740 (5,102)	720 (4,964)
600	1,480 (10,205)	1,440 (9,929)

Operating Temperature Range		
Meter with	Carbon-Steel Flanges	Stainless-Steel Flange
Pickup coils and preamps	-20 °F to 158 °F (-29 °C to 70 °C)	-50 °F to 158 °F (-46 °C to 70 °C)
Pickup coils and preamps with 24-inch standoff	-20 °F to 225 °F (-29 °C to 107 °C)	-50 °F to 225 °F (-46 °C to 107 °C)

**NOTE:** Consult factory for temperatures outside noted ranges.

## Approvals

Electrical safety for hazardous locations are as follows:

### North American and countries following the United States National Electrical Code (US NEC)

- Underwriters Laboratories (UL/CUL) File E23545; must be manufactured in the Erie, Pennsylvania, USA, plant
- Class I, Division 1, Groups C & D
- Class I, Zone 1, Tamb = -50 °C to 70 °C, IP66
- UNL-UL ENCL 4, CNL ENCL 4

### International

- IECEx PTB 08.0040X (meter); may be manufactured in the Erie, Pennsylvania, USA, or Ellerbek, Germany, plant  
Exd IIC T3-T6 Tamb = -40 °C to +70 °C, IP66

- IECEx PTB 10.0052X (GP junction box); may be manufactured in the Erie, Pennsylvania, USA, or Ellerbek, Germany, plant  
Exd IIC T4-T6 Gb Tamb = -40 °C to +70 °C, IP66

### Brazil

- UL BR 25.1036X (meter); must be manufactured in the Erie, Pennsylvania, USA, plant  
Ex d IIC (T3-T6) Gb Tamb = -40 °C to +70 °C, IP66
- UL BR 25.1042X (GP junction box); must be manufactured in the Erie, Pennsylvania, USA, plant  
Ex d IIC (T4-T6) Gb Tamb = -40 °C to +70 °C, IP66

### Russia

- Eurasian Conformity (EAC); must be manufactured in the Ellerbek, Germany, plant
- Consult factory for others

### European Union

- Explosive Atmospheres (ATEX) Directive, ATEX 2014/34/EU
- PTB 08 ATEX 1034X (meter); must be manufactured in the Erie, Pennsylvania, USA, plant  
PTB 11 ATEX 1001X (meter); must be manufactured in the Ellerbek, Germany, plant  
Exd IIC T3-T6 Gb Tamb = -40 °C to +70 °C, IP66
- PTB 10 ATEX 1039X (GP junction box); must be manufactured in the Erie, Pennsylvania, USA, plant  
PTB 10 ATEX 1031X (GP junction box); must be manufactured in the Ellerbek, Germany, plant  
Exd IIC T4-T6 Gb Tamb = -40 °C to +70 °C, IP66

## Weights and Measures

- Canadian NOA AV-2451; 8" model ONLY, must be manufactured in the Erie, Pennsylvania, USA, plant
- PTB Issued OIML R117-1 Test Report; may be manufactured in the Erie, Pennsylvania, USA, or Ellerbek, Germany, plant
- European Union (EU): Measuring Instrument Directive (MID), MID 2014/32/EU; must be manufactured in the Ellerbek, Germany, plant
- Brazil: INMETRO/DIMEL; must be manufactured in the Erie, Pennsylvania, USA, plant
- Russia: EAC; must be manufactured in the Ellerbek, Germany, plant
- Consult factory for others

## Pressure Safety Requirements

- EU: Pressure Equipment Directive (PED), PED 2014/68/EU; must be manufactured in the Ellerbek, Germany, plant
- Canadian Registration Number (CRN) consult factory; must be manufactured in the Erie, Pennsylvania, USA, plant
- Consult factory for others

## Electromagnetic Compatibility (EMC)

- EU: EMC Compliance by Council Directive EMC Directive 2014/30/EU; may be manufactured in the Erie, Pennsylvania, USA, or Ellerbek, Germany, plant
- EN 61326-1: Electrical equipment for measurement, control, and laboratory use; may be manufactured in the Erie, Pennsylvania, USA, or Ellerbek, Germany, plant

## Installation

The meter must be mounted in a horizontal attitude ( $\pm 5^\circ$ ) within a suitable flow conditioning assembly and it is recommended that the meter be installed

downstream of a strainer for protection and upstream of the flow control valve in the system.

Refer to the Smith Meter Turbine Meters Models 4" through 24" Sentry Installation/Operation Manual ([MNO2003](#)) for detailed instructions.

## Applications

### High Viscosity

The flow range of turbine meters is reduced considerably when metering viscous liquids. The minimum flow rate must be increased as the viscosity increases. The following formulas can be used to approximate the increase (reduction in range) to maintain the stated linearity:

$$\frac{\text{Viscous Minimum Rate}}{\text{Normal Minimum Rate}} = \frac{\text{Normal Minimum Rate}}{\text{Normal Minimum Rate}} \times \frac{\text{Viscosity (cP)}}{\text{Meter Size (in)}}$$

where viscosity (cP) > meter size (in).

**NOTE:** Use caution when dealing with liquids that result in a viscous minimum rate greater than one time the normal because variations in operating temperature can result in substantial meter factor shifts.

### Low Density

When metering light hydrocarbons, such as liquefied petroleum gas (LPG) or other liquids with specific gravity less than 0.8, the minimum flow rate should be shifted up. The amount of shift can be approximated by multiplying the normal minimum flow rate by the following factor:

$$\text{Rate Increasing Factor} = \frac{0.9}{\text{SG}}$$

where SG is the specific gravity of the liquid being metered.

## Minimum Back Pressure

In order to prevent cavitation, API MPMS Chapter 5 recommends a minimum back pressure according to the following formula:

$$BP = (2 \times \Delta P) + 1.25 VP$$

where:

- BP = minimum back pressure
- $\Delta P$  = pressure drop at maximum flow rate
- VP = absolute vapor pressure at operating temperature

For example, a 6" Sentry at 4,000 BPH -  $\Delta P = 6$  psi. Absolute vapor pressure of butane at operating temperature - VP = 50 psia.

$$\begin{aligned} \text{Minimum BP} &= (2 \times 6) + 1.25 (50) \\ &= 74.5 \text{ psi} \end{aligned}$$

## Pressure Drop

Linearities and pressure drops are based on 0.82 specific gravity, 1 mPa·s (1.5 cP) liquid.

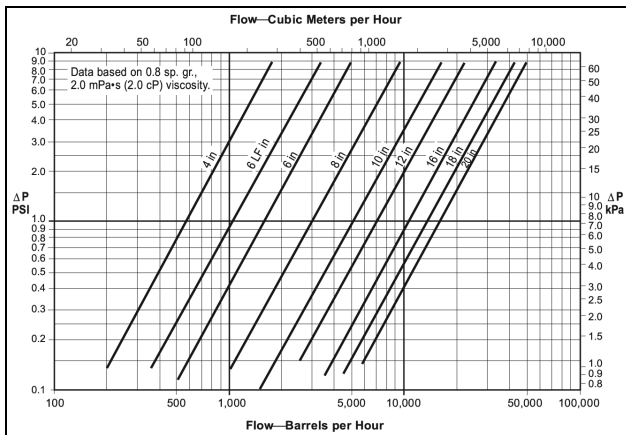

## Pickup Coil Specifications

The coil type is variable reluctance.

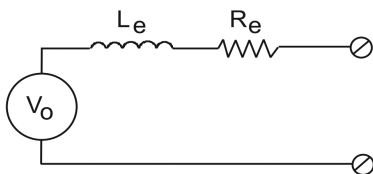

## Electrical Characteristics

- Effective series resistance ( $R_e$ ): 1,020 ohms ( $\pm 20\%$ )
- Effective series inductance ( $L_e$ ): 450 megahertz (mH) @ 1,000 hertz (Hz)
- Minimum open circuit voltage ( $V_o$ ): 300 millivolts peak to peak (mVpp) at minimum flow rate
- Maximum transmission distance: 2,000 feet (ft) (610 meters (m)) using #20 American Wire Gauge (AWG) two-conductor, shielded cable

**NOTE:** A preamplifier is recommended for remote instrumentation that does not have common-mode noise rejection. See the PA-6 specifications ([SS02012](#)) for details.

## Preamplifiers

### PA-6

Preamplifiers, optional with all Sentry model turbine meters, are recommended for remote instrumentation that does not have common mode noise rejection. See the PA-6 specifications ([SS02012](#)) for more information.

### AccuLERT™

The AccuLERT smart preamplifier is available in lieu of the standard PA-6 preamplifier. See the Smith Meter AccuLERT Smart Pre-Amp ID 2000 specifications ([SS02015](#)) for more information.

### PA-IS-1

The PA-IS-1 is an intrinsically-safe preamplifier available in lieu of a standard preamplifier. This model is only Ex certified for areas accepting ATEX certifications.

### MMRT-II

The MMRT-II local rate/totalizer is available in lieu of a standard preamplifier. See the MMRT-II Rate

Totalizer specifications ([SS09045](#)) for hazardous location certification details.

**NOTE:** The MMRT-II is intended as a reference-only local indication device. It does not have weights and measures approvals to be used for indications in legal-for-trade transactions.

## Catalog Code

The following guide defines the correct turbine meter for a given application and its respective catalog code. This code is part of the ordering information and should be included on the purchase order.

1	2	3	4	5	6	7	8	9	10	11
K	2	D	G	A	0	A	3	0	0	0

### Position 1: Code

K—Catalog code

### Position 2: Product Line

2—Turbine meter

### Positions 3: Model and Size

D—Sentry Series, ASME end connections

### Position 4: Size and Type

R—4"

V—4" high resolution

G—6"

F—6" low flow

W—6" low flow, high resolution

S—6" high resolution

H—8"

T—8" high resolution

J—10"

K—12"

L—16"

M—18"

## Position 5: Pressure Class

ASME End Connections (ASME B16.5)

A—Class 150

B—Class 300

D—Class 600

## Position 6: End Connections

**NOTE:** Low temperature (below -20 °F) requires stainless-steel end connections.

0—Carbon-steel RF flanges

F—304 Stainless-steel RF flanges

## Position 7: Internal Configuration

A—Unidirectional flow, 430 stainless-steel buttons

B—Bidirectional flow, 430 stainless-steel buttons

## Position 8: Pickup Coils and Preamplifiers

### Meter-Mounted Junction Boxes with Pickup Coils

3—Two pickup coils and two preamplifiers

E—Two PA-IS-1 with pickup coils and two PA-IS-1 preamplifiers; must be manufactured in the Ellerbek, Germany, plant

### Pickup Coils with Explosion-Proof Totalizer/Flow Rate Indicator

9—MMRT-II with one PA-6 preamplifier and two pickup coils

### Pickup Coils with Online Diagnostics

T—Two pickup coils and AccuLERT XU

### Extended Temperature Range with Online Diagnostics on 24" Standoff

J—Two pickup coils and two preamplifiers

### Extended Temperature Range with Explosion-Proof Totalizer/Flow Rate Indicator on 24" Standoff

K—Two pickup coils and AccuLERT XU

### Extended Temperature Range with Explosion-Proof Totalizer/Flow Rate Indicator on 24" Standoff

L—MMRT-II with one PA-6 preamplifier and two pickup coils

### Position 9: Testing/Linearity

0— $\pm 0.15\%$

1— $\pm 0.10\%$  (5:1 flow turndown)

2— $\pm 0.07\%$  (5:1 flow turndown)

3—Special testing

### Position 10: Compliance with Standards

0—UL/CUL listed; must be manufactured in the Erie, Pennsylvania, USA, plant

3—ATEX/IECEX certified; must be manufactured in the Erie, Pennsylvania, USA, plant

4—ATEX/IECEX/PED certified; must be manufactured in the Ellerbek, Germany, plant

5—UL/CUL/CRN; must be manufactured in the Erie, Pennsylvania, USA, plant

6—UL Brazil/INMETRO; must be manufactured in the Erie, Pennsylvania, USA, plant

### Position 11: Specials

0—None

X—Special, specify

## Dimensions and Weight

The dimensions in the drawing below are shown in inches to the nearest tenth (millimeters to the nearest whole mm), each independently dimensioned from respective engineering drawings.

Consult the factory for the dimensions of meters with AccuLERT and MMRT-II options.

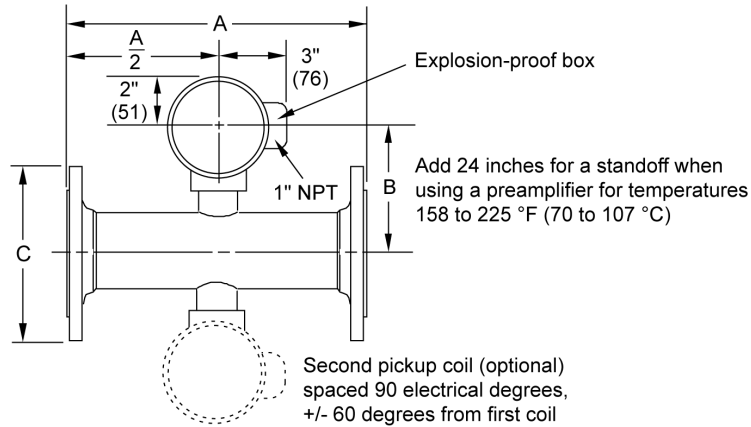

Size	A	B	Class 150 ASME		Class 300 ASME		Class 600 ASME	
			C	Weight	C	Weight	C	Weight
4"	12.0" (305 mm)	5.8" (149 mm)	9.0" (228 mm)	65 lb (30 kg)	10.0" (254 mm)	85 lb (38 kg)	10.8" (273 mm)	110 lb (50 kg)
6" LF	14.0" (356 mm)	6.9" (175 mm)	11.0" (279 mm)	135 lb (61 kg)	12.5" (318 mm)	185 lb (84 kg)	14.0" (356 mm)	295 lb (134 kg)
6"	14.0" (356 mm)	6.9" (175 mm)	11.0" (279 mm)	100 lb (kg)	12.5" (318 mm)	145 lb (66 kg)	14.0" (356 mm)	245 lb (111 kg)
8"	16.0" (406 mm)	7.9" (201 mm)	13.5" (343 mm)	155 lb (70 kg)	15.0" (381 mm)	230 lb (104 kg)	16.5" (419 mm)	320 lb (114 kg)
10"	24.0" (610 mm)	9.0" (228 mm)	16.0" (406 mm)	265 lb (120 kg)	17.5" (445 mm)	350 lb (159 kg)	20.0" (508 mm)	560 lb (294 kg)
12"	30.0" (762 mm)	10.0" (253 mm)	19.0" (483 mm)	385 lb (175 kg)	20.5" (521 mm)	575 lb (261 kg)	22.0" (559 mm)	750 lb (340 kg)
16"	40.0" (1,016 mm)	11.6" (294 mm)	23.5" (597 mm)	835 lb (379 kg)	25.5" (648 mm)	1,080 lb (490 kg)	-	-
18"	45.0" (1,143 mm)	12.6" (320 mm)	25.0" (635 mm)	1,060 lb (481 kg)	28.0" (711 mm)	1,405 lb (638 kg)	Consult the factory	-

**NOTE:** Meter weights are by flange class with one pickup coil and an explosion-proof box. Add 5 pounds (2.3 kilograms) for each additional pickup coil and explosion-proof box.



---

The specifications contained herein are subject to change without notice and any user of said specifications should verify from the manufacture that the specifications are currently in effect. Otherwise, the manufacturer assumes no responsibility for the use of specifications which may have been changed and are no longer in effect.

USA  
1602 Wagner Avenue  
Erie, PA 16510 USA  
+1 814.898.5000

Corporate Headquarters  
5825 North Sam Parkway West  
Suite 120  
Houston, TX 77086 USA

Germany  
Regentstrasse 1  
25474 Ellerbek, Germany  
+49 4101 304.0

[GuidantMeasurement.com](https://www.GuidantMeasurement.com)  
© 2025 Guidant Corporation  
All rights reserved.