

PRIME 4

SS01096 Issue/Rev. 2.4 (11/25)



Smith Meter[®] PD Meter

The Smith Meter PRIME 4 meter is a 4-inch, single-case, positive-displacement meter designed for maximum accuracy and reliability. The PRIME 4 meter is ideal for loading-rack service and custody transfer of petroleum products.

Applications include gasolines and oxygenates, ethanol, kerosene, diesel fuel, jet fuels, and fuel oils.

Features

- Minimal slippage for outstanding linearity and maximum accuracy
- Unique flow pattern minimizes pressure drop to less than 3.2 pounds-force per square inch (psi) at extended maximum flow

Features

- Unique and reliable design with only three moving parts results in low initial cost and minimum maintenance; direct pulse output eliminates the mechanical drive train resulting in fewer parts to fail and no need for a packing gland
- Horizontal rotor and specially designed journal bearings minimize wear for long service life
- Polyketone blades show decreased wear over time and keep the meter stable between proving intervals, resulting in time and cost savings

Specifications

Flow Range

Units	Extended Minimum	Normal Flow Range		Extended Maximum
		Minimum	Maximum	
GPM	45	75	750	900
l/min	190	285	2,850	3,400

Operating Temperature Range

- Standard: Low temperature fluoroelastomer (FKM) seals -20 to 200 °F (-29 to 93 °C)
- Nonstandard: Consult the factory

NOTE: The low-temperature FKM seals are suitable for all loading rack fuels, blends, and additives. Consult the factory regarding nonstandard seals.

End Connections	Housing/ Cover Material	Maximum Working Pressure at 100 °F			
		psig	kPa	bar	Pressure Code
4" ANSI 150	Steel	285	1,965	19	B31.3
DN 100, PN 16	Steel	232	1,600	16	PED
DN 100, PN 25	Steel	362	2,500	25	PED

NOTE: American National Standards Institute (ANSI) and Deutsches Institut für Normung (DIN) flanges are raised face.

NOTE: The Pressure Equipment Directive (PED) is required for all European countries. Equipment must be manufactured by the TechnipFMC Ellerbek, Germany, facility.

Quadrature (Dual-Output Signal)

Two discrete pulse channels are generated 90 electrical degrees out-of-phase with each other. By monitoring these signals with a pulse sequence comparator, the integrity of the system can be checked for pulse transmission errors (noise), loss of transmitter power, malfunctioning transmitter, and faulty transmission cable.

Accuracy

The accuracy of the PRIME 4 meter is applicable to loading rack products from gasoline to fuel oil, as follows:

- Repeatability: $\pm 0.02\%$
- Linearity:
 - $\pm 0.15\%$ over the normal flow range
 - $\pm 0.25\%$ over the extended flow range

(Linearity is based on kerosene: 0.82 specific gravity (sp. gr.SG), 1.4 millipascal-second (mPa•s), 1.5 centipoise (cP).)

- Stability: Better than $\pm 0.05\%$ per 10 million gallons (38 million liters)

Maximum Viscosity

The maximum viscosity of the PRIME 4 meter is up to 100 mPa•s.

Pressure Drop (ΔP)

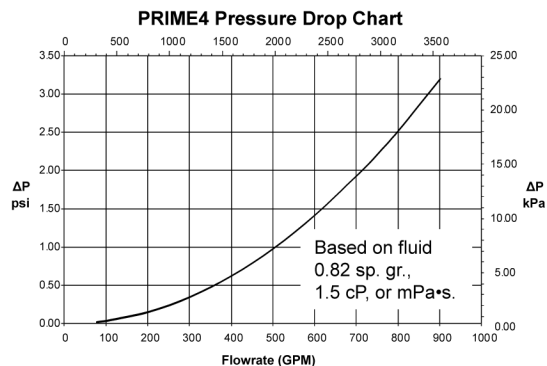

Pulse Pick-Up Sensor

- Type: Square wave/current sinking
- Input: 6-28 voltage direct current (VDC), 30 milliampere (mA) maximum, 20 mA typical
- Output signal:
 - Voltage high: See "PRIME 4 Sensor Peak Direct Current (DC) Output" on the next page
 - Voltage low: 0.8 VDC at 20 mA sink current
 - Duty cycle: 70% on, 30% off to 30% on, 70% off
- Quadrature: Separation for dual-output signal is 90 ± 40 electrical degrees.
- Pulse resolution: 50 pulses per gallon (13 pulses per liter)

PRIME 4 Sensor Peak Direct Current (DC) Output

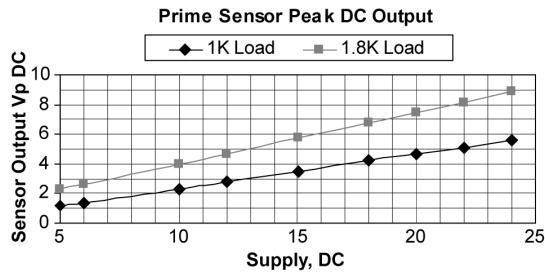

Signal cable

The PRIME4 meter uses four-wire shielded signal cable for dual-channel transmission.

Size	Distance
#20 AWG	Up to 2,000 feet (ft) (610 meters (m))
#18 AWG	Up to 3,000 ft (915 m)
#16 AWG	Up to 5,000 ft (1,525 m)

NOTE: Cable-loop resistance must be limited to 50 ohms maximum (cable loop resistance = 2 x cable length (ft) x cable resistance (ohms/ft).)

Wiring Connections

- Red: 6-28 VDC
- Black: Common
- White: Signal A
- Yellow: Signal B

Electrical Safety Approvals

- US and Canada: UL/CUL Listed for use in Class I, Division 1, Groups C and D; Class I, Zone 1, Group IIB, UNL-UL Enclosure 4X, CNL-CSA Enclosure 4; Tamb = -40 to +70 °C
- European: Ex db IIC T5...T6 Gb Tamb -50 to +70 °C, IP 65
 - Ex ib IIC T5...T6 Gb -50°C ≤ Ta ≤ 70°C
 - DEMKO 19 ATEX 2266X
- Global: Ex db IIC T5...T6 Gb Tamb -50 to +70 °C, IP 65

- Ex ib IIC T5...T6 Gb -50°C ≤ Ta ≤ 70°C
- IECEx UL 22.0085X
- INMETRO (Brazil): Ex db IIC T6 Tamb = - 50 °C ≤ Tamb ≤ + 70 °C, IP 65
 - UL BR 25.1045X

Weights & Measures Certifications

- NTEP (US) CoC #96-099
- Measurement Canada (Canada) NOA AV-2323
- OIML R117 evaluation report issued by NMi (Netherlands)
- PTB issued MID system certificates are available for the EU
- INMETRO (Brazil) DIMEL No. 0144

Materials of Construction

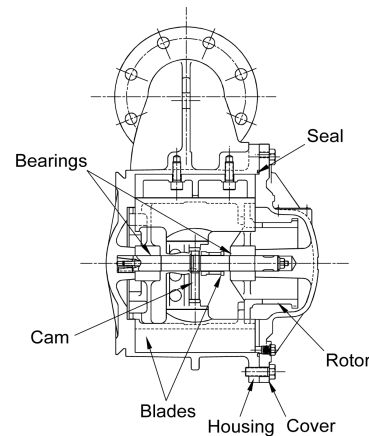

- Housing and cover: Steel
- Blades: Polyketone
- Rotor: Cast iron
- Cam: Hard-surfaced steel
- Bearings: Journal-type cast iron/hard-surfaced steel
- Seals: Low-temperature FKM

Dimensions

Inches (") are to the nearest tenth (millimeters (mm) to the nearest whole mm), each independently dimensioned from respective engineering drawings.

(A) 3/4" NPT Thermal Well

(B) 1/4" NPT Drain/Vent Plug (three places)

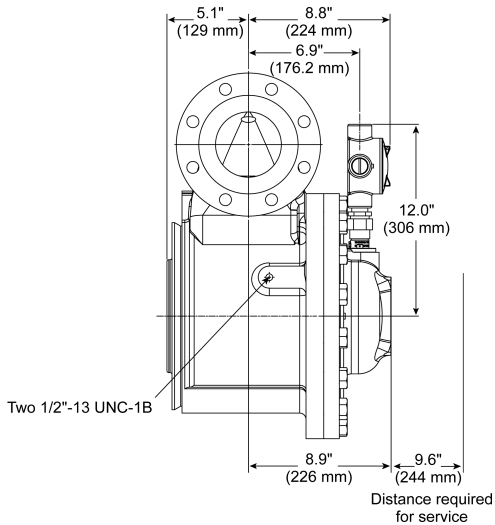
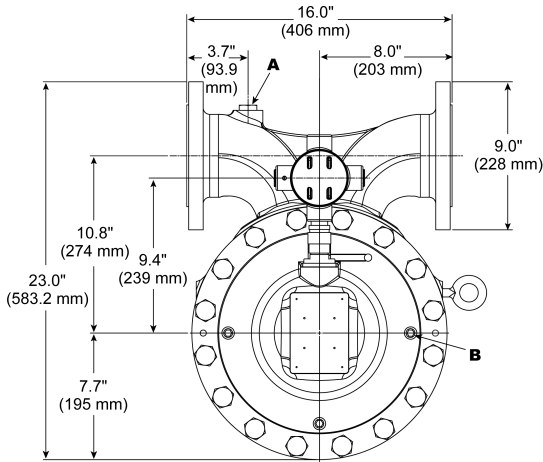

Weight

Weight is measured in pounds (lb) and kilograms (kg). The PRIME4 meter weighs 310 pounds (lb) (140 kg).

Catalog Code

The following guide defines the correct PRIME 4 meter for a given application and the respective catalog code.

This code is part of the ordering information and should be included in the purchase order.

PRIME 4 Catalog Code Example

1	2	3	4	5	6
PRIME 4	B	4	1	0	0

Position 1: Model Designation

PRIME 4

Position 2: End Connections and Working Pressure

- B—4" ASME Class 150, 285 psig (19 bar), steel
- C—DN 100, PN 25, 25 bar, (362 psig), steel
- E—DN 100, PN 16, 16 bar, (232 psig), steel

Position 3: Elastomers

- 4—Low-temperature FKM seals

Position 4: Sensor Selection

- 1—Dual-output signal

Position 5: Hazardous Locations Approval

- 0—UL/CUL/ATEX/IECEX
- 1 – ATEX/IECEX
- 2 – UL Brazil

Position 6: Pressure Certification Requirement

- 0—Not required
- 1—CRN required
- 2—PED required
- 3—Special (consult the factory)

NOTE: PED is required for all European countries. Equipment must be manufactured by the Ellerbek, Germany, facility.

NOTE: If Pressure Certification Requirement option #2 (PED required) is selected, then

Hazardous Locations Approval option #1 (ATEX/IECEX) is required.

Arrangement

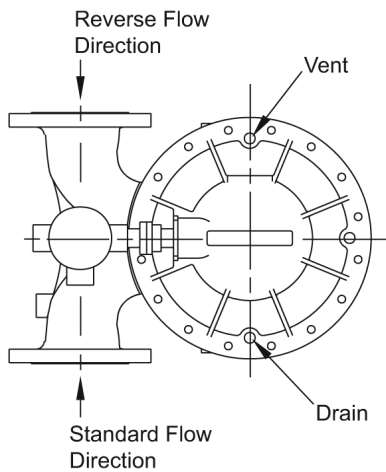
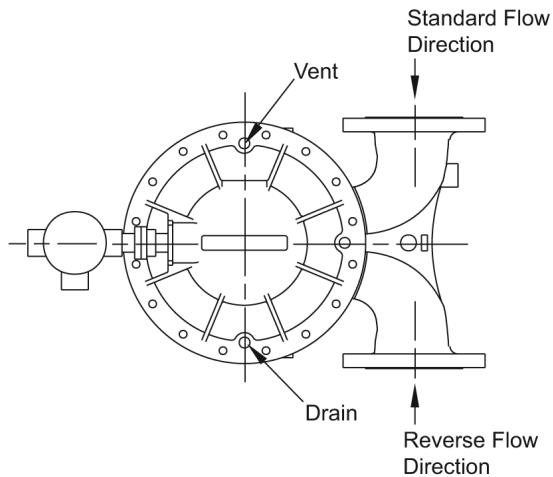
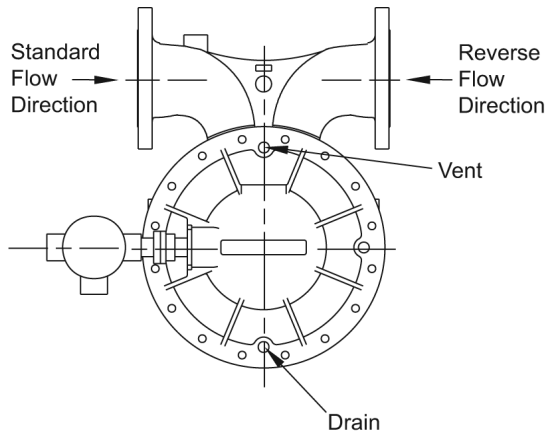

NOTE: The drain must always be in a down position, as shown. The vent source should always be at the highest vertical point of the meter. The cover vent may not always be at this point and an alternate vent source should be used.

NOTE: Horizontal flow with nozzles down is an alternate arrangement; however, it is not preferred because external drain plugs in the piping are required. If this arrangement is used, the cover should be rotated to place the drain in the down position.

The specifications contained herein are subject to change without notice and any user of said specifications should verify from the manufacture that the specifications are currently in effect. Otherwise, the manufacturer assumes no responsibility for the use of specifications which may have been changed and are no longer in effect.

USA
1602 Wagner Avenue
Erie, PA 16510 USA
+1 814.898.5000

Corporate Headquarters
5825 North Sam Parkway West
Suite 120
Houston, TX 77086 USA

Germany
Regentstrasse 1
25474 Ellerbek, Germany
+49 4101 304.0

[GuidantMeasurement.com](https://www.GuidantMeasurement.com)
© 2025 Guidant Corporation
All rights reserved.