

6" Steel Model G6

Bulletin SS01014 Issue/Rev. 1.1 (10/21)

Smith Meter® PD Meters

The Smith Meter Model G6 is a 6", steel, double-case, straight-through rotary-vane type positive displacement meter. Applications for the G6 include blending, batching, dispensing, inventory control, and custody transfer of oils, solvents, chemicals, paints, fats and fertilizers.

Features

- Superior accuracy—Smith Meter's rotary-vane meter principle, combined with the meter's uniquely designed (offset) inlet and outlet nozzles, maximizes accuracy by minimizing pressure drop across the measuring chamber reducing slippage (flow through meter clearances).
- Low pressure drop—Streamlined flow path provides low pressure drop.
- Positive and accurate registration—High-torque drive calibrator with adjustment in 0.05 percent (%) increments ensures accurate registration.
- Long service life—Low-friction ball bearings, fixed cam-type timing, and rugged construction provide sustained accuracy and long service life.

Options

- High-viscosity meter clearances extend operation at maximum flow rate from 400 to 2,000 millipascal-second (mPa•s).
- High-temperature clearances extend operating temperatures from 150 to 200 degrees Fahrenheit (°F) (65 to 93 degrees Celsius (°C)).
- All iron trim option for operating temperatures above 200 °F (93 °C).
- Liquefied petroleum gas (LPG) trim option for low-lubricity liquids, such as LPG.
- Compliant with NACE standard MR-01-75.
- ASME Section VIII vessel construction is available for model G6-S3.



Generic Illustration

Operating Specifications

Maximum Flow Rate

	USGPM	L/min
Continuous rating with standard trim	1,000	3,750
Intermittent rating ¹ with standard trim	1,200	4,600
Continuous/intermittent rating with all iron or LPG trim	750	2,800

Minimum Flow Rate (Typical Performance)

Linearity ²	Units	Viscosity (Centipoise—mPa•s)					
		.5	1	5	20	100	400
±0.15%	USGPM	160	100	40	8	1.40	0.70
	L/min	606	378	152	30	5.30	2.65
±0.25%	USGPM	120	75	30	6	1.00	0.50
	L/min	455	284	114	23	3.80	1.90
±0.50%	USGPM	80	50	20	4	0.70	0.35
	L/min	303	190	76	15	2.65	1.33

US gallons per minute (USGPM) and liters per minute (L/min)

1 Intermittent rating applies to service on clean, refined products where continuous operation is not required (for example, truck loading, rail loading, and other batching applications).

2 Linearity based on a maximum flow rate of 1,000 USGPM (3,750 L/min) unless otherwise stated.

3 1,000 mPa•s = 1,000 cP = 1 Pa•s.

Repeatability

±0.02%

Viscosity

Standard: 400 mPa·s³ (2,000 Seconds Saybolt Universal (SSU)) maximum

Optional: 2 pascal seconds (Pa·s) (10,000 SSU) maximum and specify "High Viscosity Meter Clearances"

Over 2 Pa·s: Specify "High Viscosity Meter Clearances" and derate maximum flow rate in direct proportion to viscosity over 2 Pa·s. For example, at 4 Pa·s, derate maximum flow rate to 50% of normal continuous rating 500 USGPM.

Temperature

Standard meter clearances with:

- Buna-N/PTFE⁹: -20 °F to 150 °F (-29 °C to 65 °C).
- FKM¹⁰: 10 °F to 150 °F (-12 °C to 65 °C).
- Low temp. FKM^{10,11}: -50 °F to 150 °F (-46 °F to 65 °C)

High temperature meter clearances with:

- Buna-N/PTFE⁹: -20 °F to 200 °F (-29 °C to 93 °C).
- FKM¹⁰: 10 °F to 200 °F (-12 °C to 93 °C).
- Low temp. FKM^{10,11}: -50 °C to 200 °F (-46 °C to 93 °C)

All iron trim with:

- Buna-N: -20 °F to 225 °F (-29 °C to 108 °C).
- PTFE⁹: -20 °F to 400 °F (-29 °C to 205 °C).
- FKM¹⁰: 10 °F to 400 °F (-12 °C to 205 °C).
- Low temp. FKM^{10,11}: -50 °C to 400 °F (-46 °C to 205 °C)

Meter Gearing

Five US gallons, 1 barrel, or 5 dekaliters per revolution of meter calibrator output shaft.

Maximum Working Pressure			
Model	Flange	PSI ⁴	kPa ⁴
G6-S3	150	285 ⁴	1,965 ⁴
G6-S5	300	300 ⁴	2,068 ⁴
G6-S6	300	740 ⁴	5,102 ⁴
G6-S7	600	1,480 ⁴	10,204 ⁴
G6-S8	900	2,220 ⁴	15,307 ⁴

Note: Flange class per ANSI B16.5 raised-face flange.

Pressure Drop (ΔP)

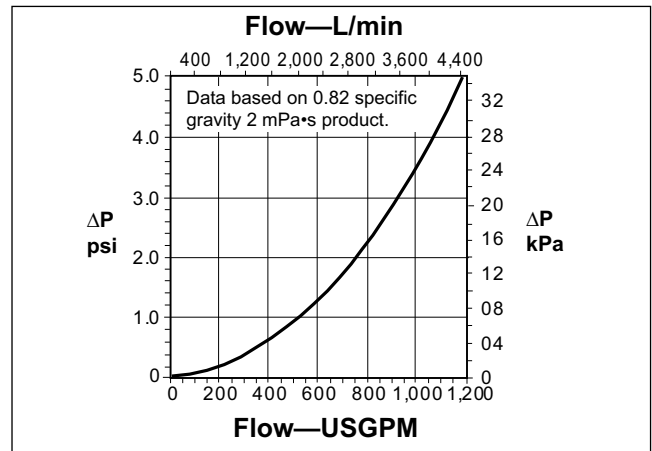

Materials of Construction

Trim	Housing	Internals	Seals
Standard	Steel	Iron, steel, stainless steel, aluminum	Buna N ⁵ , PTFE ⁹ , FKM ¹⁰ , or Low temp. FKM ^{10,11}
LPG	Steel	Iron, steel, stainless steel, aluminum, rulon, and nylon	Buna N ⁵ , PTFE ⁹ , FKM ¹⁰ , or Low temp. FKM ^{10,11}
All Iron	Steel	Iron, steel, stainless steel	Buna N ⁵ , PTFE ⁹ , FKM ¹⁰ , or Low temp. FKM ^{10,11}

Installation

It is recommended that the meter be protected with a suitable mesh strainer.

Weights and Measures Approvals

United States—NTEP CC 95-054
 Canada—NOA S.WA-0615
 Australia—5/6B/55B
 PTB Issued OIML R117-1 Test Report
 PTB Issued MID certificate
 Brazil—INMETRO
 Russia—GOST
 For others, consult factory.

Pressure Safety

Canadian CRN

³ 1,000 mPa·s = 1,000 cP = 1 Pa·s.

⁴ Maximum working pressure at 100 °F (38 °C).

⁵ Standard.

⁶ Specify minimum/normal/maximum.

⁷ Standard seals supplied unless optional material specified.

⁸ Not compatible with higher pressure models.

⁹ Polytetrafluoroethylene (PTFE).

¹⁰ Fluoroelastomer (FKM).

¹¹ Only available for G6-S3 with low temperature material and ASME Section VIII design. Low temperature FKM is the standard sealing material for meters with the ASME Section VIII design.

Catalog Code

The following guide defines the correct PD meter for a given application and the respective catalog code. This code is part of the ordering information and should be included on the purchase order.

1	2	3	4	5	6	7	8	9	10
K	G	6	S	3	B	B	S	0	0

Position 1: Code

K—Catalog Code

Positions 2 and 3: Model/Flange Size

G6—6"

Position 4: Flow Path

S—Straight

Positions 5: Pressure Class and End Connections

Standard (Raised Face Flanges)

3—Class 150, 285 psig/1,965 kPa

6—Class 300, 740 psig/5,102 kPa

7—Class 600, 1,480 psig/10,204 kPa

8—Class 900, 2,220 psig/15,307 kPa

PED (Raised Face Flanges)

3—Class 150, 285 psig/1,965 kPa

6—Class 300, Consult Factory

7—Class 600, 1,480 psig/10,204 kPa

8—Class 900, 2,220 psig/15,307 kPa

All flanges designed to ANSI B16.5, pressure ratings maximum working pressure at 100 °F.

Position 6: Meter Gearing

G—Gallons (5:1 - V3, S3 through S8)

B—Barrels (1:1 - V3, S3 through S8)

D—Dekaliters (5:1 - V3, S3 through S8)

I—Imperial Gallons¹³

P—Pound¹³

Position 7: Seals

B—Buna N

L—Low Temperature FKM¹⁰

T—PTFE⁹

V—FKM¹⁰

Position 8: Trim

S—Standard

A—All Iron

L—LPG

Position 9: Temperature Compensation

0—None

A—ATC

B—ATG

Position 10: Special Requirements¹²

0—Standard

C—CRN and Low Temperature Material¹¹

L—Low Temperature Material¹¹

P—PED (consult factory)

⁹ Polytetrafluoroethylene (PTFE).

¹⁰ Fluoroelastomer (FKM).

¹¹ Only available for G6-S3 with low temperature material and ASME Section VIII design. Low temperature FKM is the standard sealing material for meters with the ASME Section VIII design.

¹² PED required for all European countries. Equipment must be manufactured by Ellerbek, Germany facility.

¹³ Consult factory for model number when selecting imperial or pound gearing.

Dimensions

Inches (Millimeters)

Model G6-S3 through S7

It is recommended that meter be protected with a suitable mesh strainer.

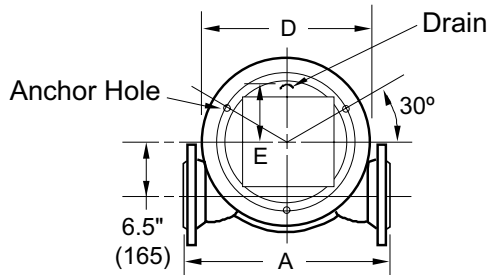

Meter Anchor Bolt Holes
3 - 0.8" (20) bolt holes on a
15" (381) diameter bolt circle.

2.9" (74) required to
open printer top

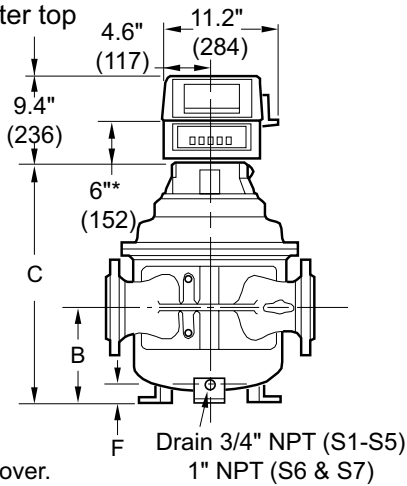

*Includes cover.

Model	A	B	C	D	E	F	Weight—lb (kg)
G6-S3	23.0" (584)	10.6" (270)	27.0" (686)	20.1" (511)	6.4" (163)	1.3" (33)	435 (197)
G6-S3 Low Temp. Material	23.0" (584)	10.6" (270)	26.7" (678)	20.3" (516)	6.8" (173)	1" (25.4)	640 (290)
G6-S5	24.0" (610)	10.6" (270)	27.0" (686)	20.1" (511)	6.4" (163)	1.3" (33)	485 (220)
G6-S6	28.9" (734)	11.5" (292)	29.6" (752)	23.0" (584)	7.3" (185)	1.4" (36)	930 (433)
G6-S7	30.9" (785)	12.0" (305)	30.9" (785)	24.3" (617)	7.3" (185)	1.4" (36)	1,305 (592)

Note: Dimensions—Inches to the nearest tenth (millimeters to the nearest whole mm), each independently dimensioned from respective engineering drawings.

Dimensions

Inches (Millimeters)

Model G6-S8

It is recommended that meter be protected with a suitable mesh strainer.

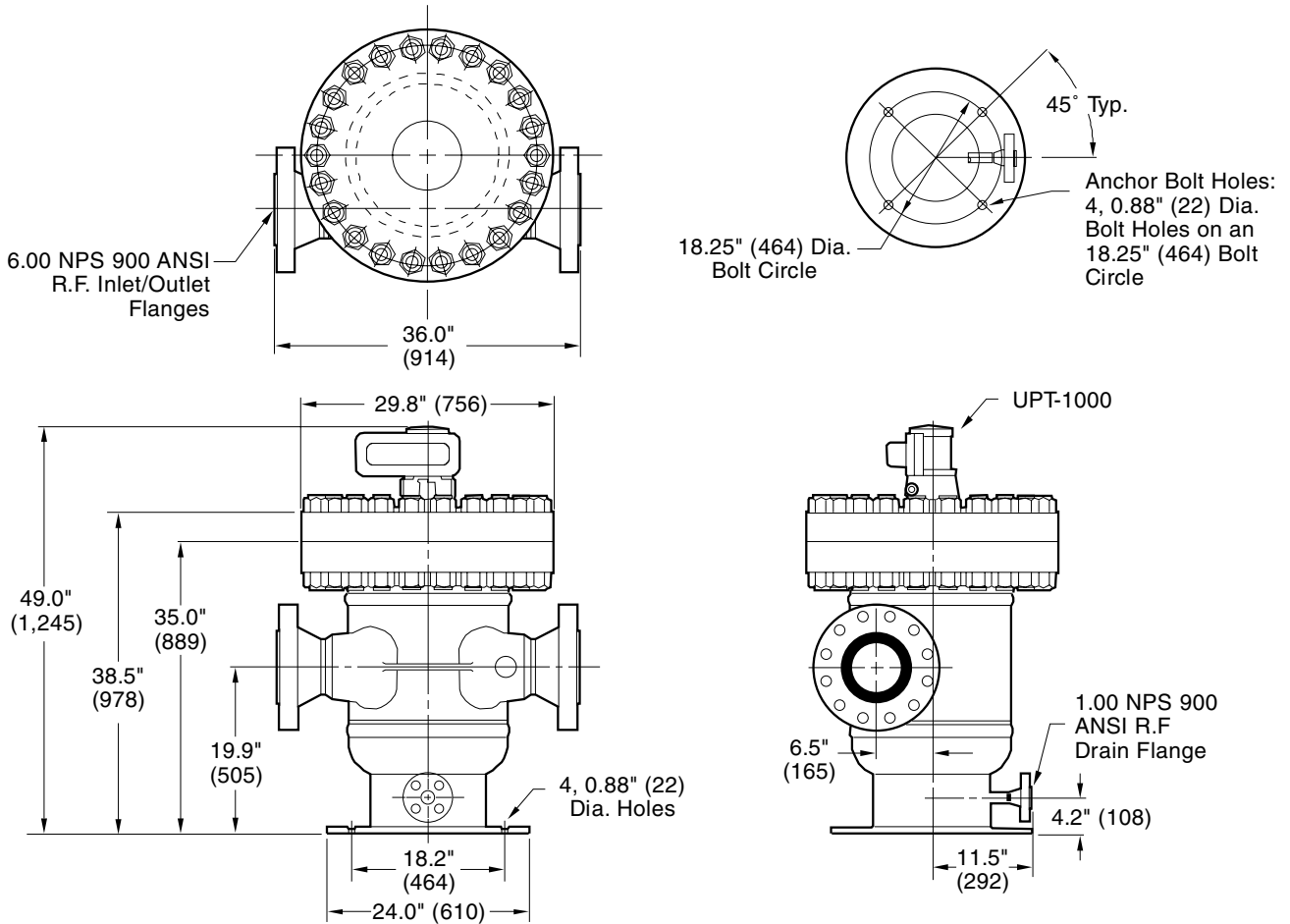

Note: Dimensions—Inches to the nearest tenth (millimeters to the nearest whole mm), each independently dimensioned from respective engineering drawings.

Weight

2,800 lb (1,273 kg)

Accessories

Strainer

6" steel, R.F. flanged, 4 mesh or finer screen.

Hydraulic Valve⁸

6" globe-type, steel, R.F. flanged, 300 psi maximum working pressure.

Air Eliminator

6" steel, R.F. flanged, 300 psi maximum working pressure.

Counters

200 Series – Accumulative, nine-digit, non-reset type.

600 Series – Five-large digit reset, eight small-digit non-reset.

Printer

Seven-digit accumulative.
Optional six-digit zero start.

Preset Counter

300C Series – Four-digit (five-digit optional) mechanical pushbutton preset with valve linkage. Microswitch package for hydraulic valve, pump control, or other interlock optional.

Pulse Transmitters

LNC Pulse Transmitter (adapts to 600 Series Counters).

Low Resolution – 1 or 10 pulses¹⁵.

High Resolution (HR) – 50 or 100 pulses¹⁵.

UPT – Quad-channel, infrared, security pulse transmitter in an explosion-proof housing (up to 1,000 pulses/rev).

Flow Rate Indicator

Direct mount mechanical.

Remote electronic.

Remote Registration

Electronic totalizers.

Automatic Temperature Compensation

Model ATC – Factory-set for a given product.

Model ATG – Field-adjustable for different products.

Ordering Information

Application	Batching, loading, blending, inventory, process control, etc.
Operating Conditions	Liquid—Name, specific gravity or API gravity, flow range ⁶ , temperature range ⁶ , viscosity range ⁶ , maximum working pressure
Seals	Buna-N ⁷ , FKM ¹⁰ , or PTFE ⁹
Units of Registration	Gallons, barrels, liters, dekaliters, pounds, kilograms, etc.
Direction of Flow	Left-to-right (as viewed above) is standard and will be supplied unless right-to-left flow is specified.
Style	Straight-through
Options and Accessories	As required

⁶ Specify minimum/normal/maximum.

⁷ Standard seals supplied unless optional material specified.

⁸ Not compatible with higher pressure models.

⁹ Polytetrafluoroethylene (PTFE).

¹⁰ Fluoroelastomer (FKM).

¹⁵ Per revolution of LNC right-hand wheel.

Revisions included in SS01014 Issue/Rev. 1.1 (10/21):

G6-S3 ASME Section VIII low temperature material information added.

Weights & Measures information added. EPR references removed. Type E Pulse Transmitter removed.

The specifications contained herein are subject to change without notice and any user of said specifications should verify from the manufacturer that the specifications are currently in effect. Otherwise, the manufacturer assumes no responsibility for the use of specifications which may have been changed and are no longer in effect.

USA Operation
1602 Wagner Avenue
Erie, Pennsylvania 16510 USA
P:+1 814.898.5000

Germany Operation
Smith Meter GmbH
Regentstrasse 1
25474 Ellerbek, Germany
P:+49 4101 304.0