

Smith Meter® PD Meter
**Meter, PD Series,
 F4-A1, S1**

Parts List Bulletin PO01006 || Issue/Rev 0.0 (7/13)



**Pre – 2008
 A1, S1**

**2008 – Present
 S1**

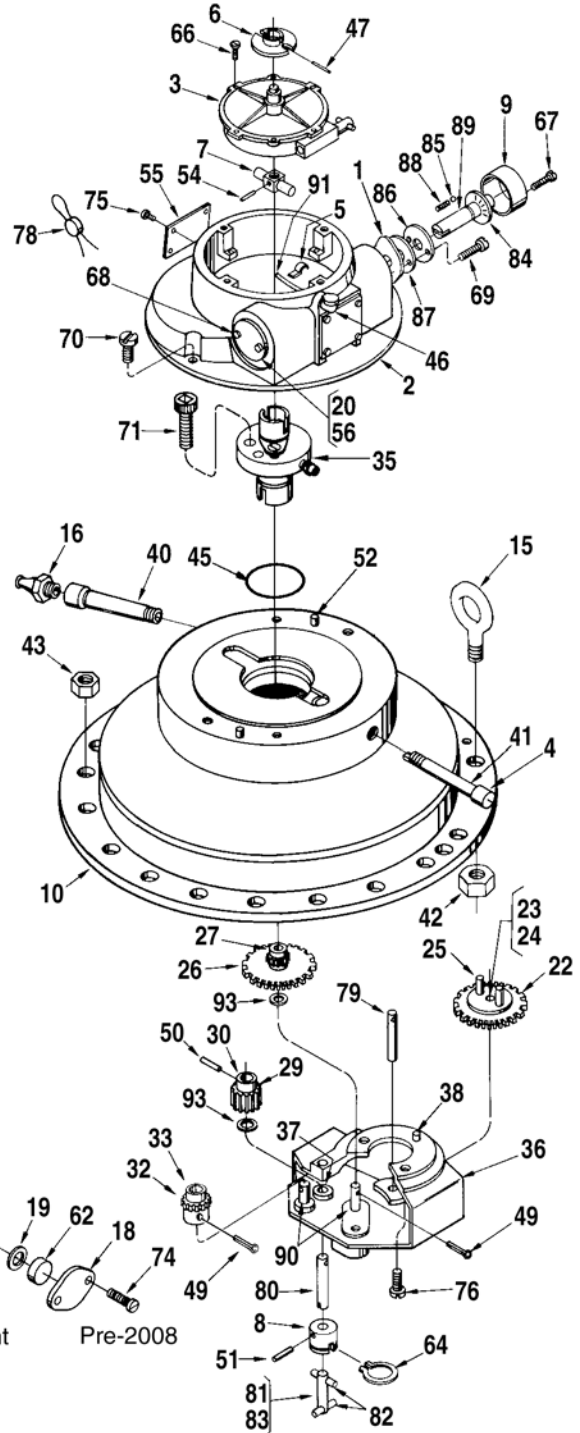
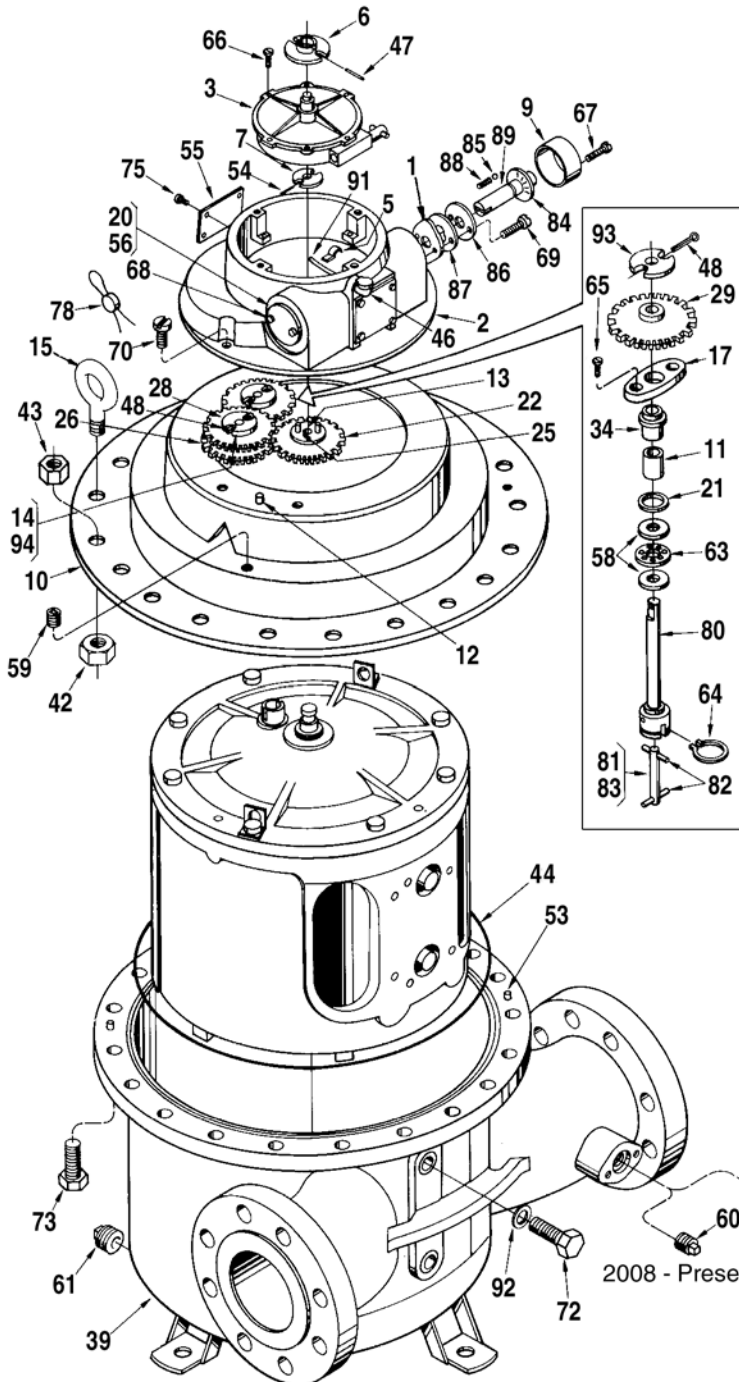

2008 - Present

Pre-2008

Inner Mechanism

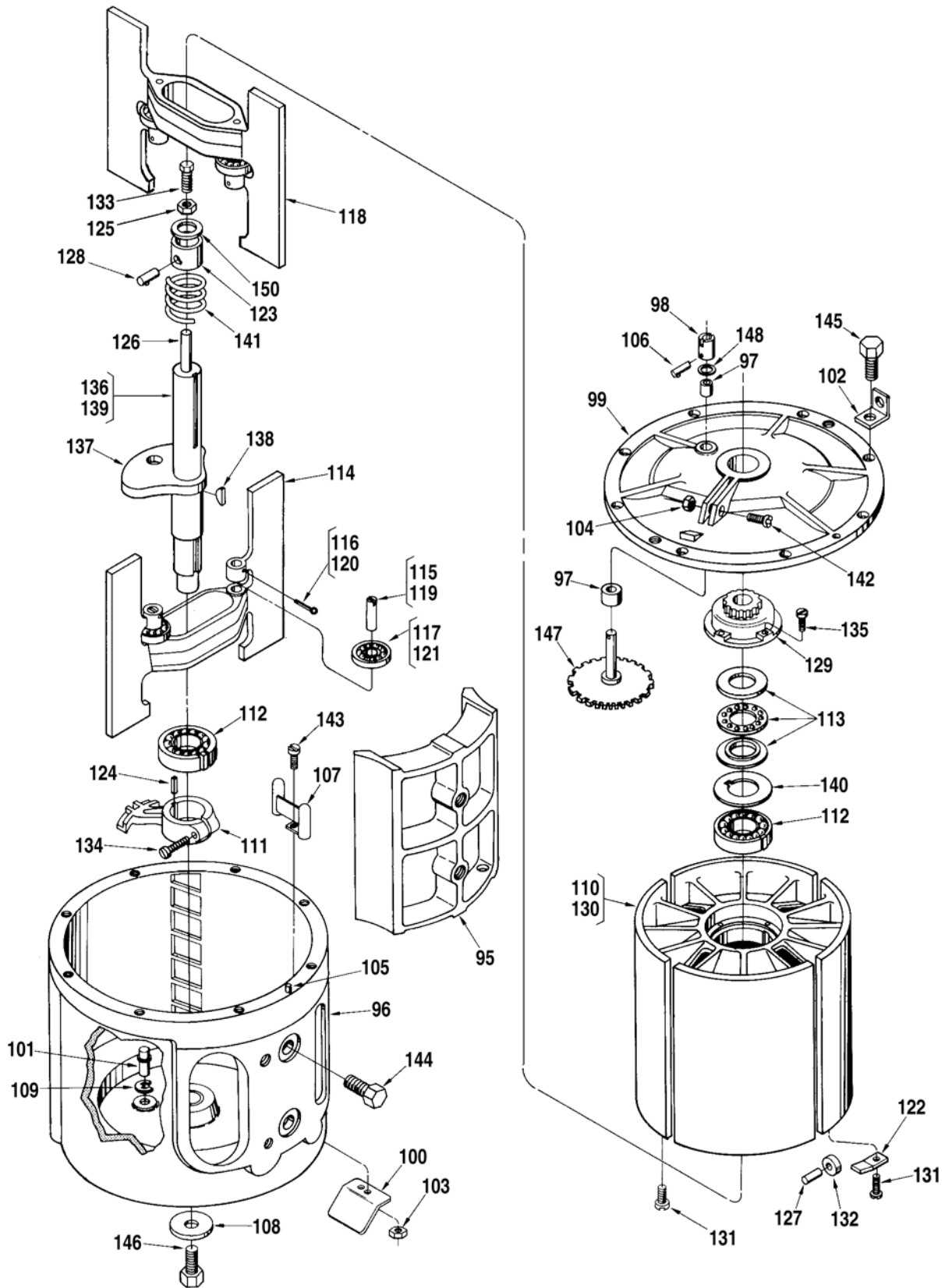

<u>Item</u>	<u>Description</u>	<u>Qty.</u>	<u>Pre-2008</u>	<u>2008-Present</u>
1	Adapter, Calibrator Adjusting Stem	1	512372-001	512372-001
2	Adapter:			
	Standard and ATC	1	511946-001	511946-001
	ATG	1	512916-001	512916-002
3	+ Calibrator:			
	Standard	1	512059-001	512059-001
	With ATC (Standard)	1	512060-001	512060-001
@1	With ATC (Special Temp. or API).....	1	516130-xxx	516130-xxx
	Dummy Calibrator	1	516105-001	516105-001
4	Cap:			
	Standard	1	641746-401
	NACE	1	645238-401
5	Clamp, Oil Tube	1	003905-001	003905-001
6	+ Coupling, Drive	1	072103-001	072103-001
7	Coupling, Input.....	1	014356-001	003821-001
8	Coupling, Jackshaft.....	1	514633-001
9	Cover, Knob	1	003553-001	003553-001
10	Cover, Outer Housing:			
	All Others	1	512125-091	512682-091
	NACE	1	552162-001
	PTFE ¹	1	512125-099
11	Bushing.....	1	519882-002
12	Pin, Groove 3/16 x 3/8".....	1	641007-401
13	Shaft, Calibrator Drive	1	003775-001
14	Shaft, Idler Pinion	1	512077-001
15	Eyebolt, for Lifting	2	644974-403	644974-403
16	Fitting, Lubrication.....	1	006408-001
17	Flange, Packing Gland.....	1	010171-001
18	Flange, Temperature Well Plug.....	1	011941-001
19	Gasket.....	1	060341-001
20	Gasket, Cover Plate.....	1	003834-001	003834-001
21	Gasket, Packing Gland	1	010173-001
22	@2 Gear, Calibrator Drive:			
	U.S. Barrels	1	516490-001	514368-001
	U.S. Barrels, LPG.....	1	516490-001	512239-001
	U.S. Gallons	1	008248-001	008248-001
	U.S. Gallons, LPG.....	1	008248-001	511858-001
	Imperial Gallons	1	071007-001	514368-001
	Imperial Gallons, LPG	1	071007-001	512239-001
	Dekalitres	1	070728-001	515934-001
	Dekalitres, LPG	1	070728-001	516373-001
23	*@6 Bushing, Standard and All Iron.....	1	013372-001	013372-001
24	*@6 Bushing, LPG	1	504653-001	504653-001
25	Pin	2	003325-001	003325-001
26	@2 Gear, Intermediate Pinion:			
	U.S. Barrels	1	516488-001	514366-001
	U.S. Barrels, LPG.....	1	516488-001	515068-001
	U.S. Gallons	1	008250-001	514770-001
	U.S. Gallons, LPG.....	1	008250-001	515071-001
	Imperial Gallons	1	072076-001	515769-001
	Imperial Gallons, LPG	1	072076-001	515072-001
	Dekalitres	1	072056-001	515932-001
	Dekalitres, LPG	1	072056-001	516372-001
27	Bushing, LPG Only	1	504653-001
28	Pin.....	2	001126-001
29	@2 Gear, Jackshaft Pinion:			
	U.S. Barrels	1	516485-001	514363-001
	U.S. Barrels, LPG	1	516485-001	515066-001
	U.S. Gallons.....	1	008249-001	514767-001
	U.S. Gallons, LPG.....	1	008249-001	515070-001

¹ Polytetrafluoroethylene (PTFE).

<u>Item</u>	<u>Description</u>	<u>Qty.</u>	<u>Pre-2008</u>	<u>2008-Present</u>
	Imperial Gallons	1	008249-001	514767-001
	Imperial Gallons, LPG	1	008249-001	515070-001
	Dekalitres	1	008249-001	514767-001
	Dekalitres, LPG	1	008249-001	515070-001
30	Bushing, LPG Only	1	504653-001
31	* Pin.....	2	001126-001
32	@2 Gear, Reversing Pinion:			
	U.S. Barrels	1	514361-001
	U.S. Barrels, LPG	1	515067-001
33	Bushing, LPG Only	1	504653-001
34	+ Gland, Packing:			
	Buna-N	1	518630-001
	Viton	1	518630-002
	PTFE ¹	1	009535-001
	Brass.....	1	008934-001
35	+@3 Gland, Packing:			
	Standard – Buna-N.....	1	513644-001
	PTFE ¹	1	513644-002
	NACE	1	551178-001
36	Housing, Gear:			
	Standard and All Iron.....	1	514628-001
	LPG	1	514628-002
37	Bushing:			
	Standard and All Iron.....	1	519882-001
	LPG	1	514835-001
38	Dowel.....	1	003628-001
39	Housing, Outer:			
	*@5 A1 – Standard (Reman Only)	1	Consult Factory	Consult Factory
	S1 – NACE	1	552982-001	552982-001
	S1 – PTFE ¹	1	552982-099	552982-099
40	Lubrication Assembly	1	514659-001
41	Nipple:			
	Standard.....	1	641111-404
	NACE	1	645185-401
42	Nut, Eyebolt	2	006399-002	006399-002
43	Nut, Hex (9/16" - 12).....	20	642138-401	642138-401
44	+ O-Ring, Cover:			
	Buna-N	1	512140-001	512140-001
	Viton	1	512140-002	512140-002
	PTFE ¹	1	645842-401	645842-401
45	+ O-Ring, Packing Gland:			
	Buna-N	1	640173-023
	Viton	1	640894-403
	PTFE ¹	1	645905-402
46	Oiler	1	006588-001	006588-001
47	Pin, Counter Drive Coupling	1	006028-002	006028-002
48	Pin, Cotter (1/16 x 5/8").....	2	641042-401
49	Pin, Cotter (1/16 x 3/8").....	2	009825-400
50	Pin, Groove (1/16 x 1/2".....	1	006054-002
51	Pin, Groove (5/64 x 5/8").....	1	009593-400
52	Pin, Groove (3/16 x 3/8").....	2	641007-401
53	Pin, Groove, Outer Cover	2	640985-401	640985-401
54	Pin, Input Coupling.....	1	006053-002	006317-002
55	Plate, Caution	1	006571-003	006571-003
56	Plate, Cover	1	003440-001	003440-001
57	* Plate, Gland Lubrication.....	1	517715-001
58	+ Plate, Thrust Bearing:			
	Standard and All Iron.....	2	001111-001
	LPG	1	504720-001

¹ Polytetrafluoroethylene (PTFE).

<u>Item</u>	<u>Description</u>	<u>Qty.</u>	<u>Pre-2008</u>	<u>2008-Present</u>
59	Plug, Pipe.....	1	006073-002
60	Plug, Pipe:			
	Standard.....	1	006505-002
	NACE	1	645242-402
61	Plug, Pipe:			
	Standard.....	1	006878-002	006878-002
	NACE	1	645242-403	645242-403
62	Plug, Temperature Well.....	1	012025-001
63	+ Retainer, Ball:			
	Standard.....	1	070360-002
	All Iron	1	070360-001
64	Ring, Snap	1	512066-001	512066-001
65	Screw, #10-32 x 1/2".....	2	006764-002
66	Screw, #6-32 x 5/16".....	2	006048-002	006048-002
67	Screw, #10-24 x 3/4", Drilled.....	2	006481-003	006481-003
68	Screw, #10-32 x 3/8".....	2	006045-002	006045-002
69	Screw, #10-32 x 7/8".....	2	640835-001	640835-001
70	Screw, Adapter to Cover:			
	5/16-18 x 3/4", Drilled	2	009563-400	009563-400
	5/16-18 x 1", Drilled	2	065075-003
71	Screw, Cap – Packing Gland to Cover (5/16-18 x 1-1/4")	2	006511-002
72	Screw, Cap – Inner Mechanism:			
	1/2-13 UNC-2A x 2" (A1 and 2008-Present S1)	2	646134-401	646134-401
	1/2-13 x 1-3/4"	2	006169-002
	NACE, 1/2-13 x 1-3/4"	2	645182-401	645182-401
73	Screw, Cap – Outer Housing:			
	A1 – 3/4-10 x 1-3/4".....	20	646186-401
	S1 – 9/16-10 x 1-3/4".....	20	640975-404
	S1 – 9/16-12 x 2-1/4".....	20	640975-403
	S1 – 3/4-10 x 4-1/4"	20	641068-409
74	Screw, Temperature Well Flange (5/16-18 x 1")	2	060133-002
75	Screw, Drive, #2 x 1/8".....	12	009880-400	009880-400
76	Screw, Gear Housing, 5/16-18 x 5/8"	2	009813-400
77	* Screw Set-Gear Housing, #10-32 x 1/4"	1	009469-400
78	+ Seal, Lead and Wire	1	001627-400	001627-400
79	+ Shaft, Calibrator Drive Gear.....	1	515341-001
80	+ Shaft, Jack (Upper).....	1	512116-001	514634-002
81	+ Shaft, Link Assembly.....	1	512069-001	514757-001
82	Pin	2	065217-402	065217-402
83	Shaft.....	1	512068-002	512068-003
84	Stem, Adjusting Assembly.....	1	009838-001	009838-001
85	Ball	2	006427-001	006427-001
86	Plate, Base	1	003552-001	003552-001
87	Plate, Retainer.....	1	003556-001	003556-001
88	Spring, Knob.....	2	003557-001	003557-001
89	Stem, Adjusting	1	003551-001	003551-001
90	Stud, Gear Shaft	2	514370-001
91	Tube, Oil.....	1	514658-001	514658-001
92	Washer.....	2	065309-002	065309-002
93	Washer, Jackshaft:			
	Pre-2008.....	1	001125-001
	2008-Present.....	3	641985-402
94	Washer, Idler Pinion Shaft.....	1	003599-001

		Inner Mechanism		
Item	Description	Qty.	Part Number	
95	+@4 Block:			
	Standard.....	1	517085-001	
	High Viscosity:			
	For 2,000 SSU to 10,000 SSU.....	1	517085-041	
96	Body.....	1	511997-001	
97	+ Bushing, Jackshaft:			
	Standard and All Iron.....	2	519882-001	
	LPG.....	2	512796-001	
98	+ Coupling, Drive.....	1	512064-002	
99	Cover, Inner (Includes Item #100):			
	Standard and All Iron.....	1	516456-001	
	LPG.....	1	516456-002	
100	Cover, Pitot.....	1	512719-001	
101	Dowel, Locating Arm.....	1	512115-001	
102	Lug, Lift.....	2	512002-001	
103	Nut, Pitot Assembly, #10-32 Hex.....	2	001723-400	
104	Nut, 5/16-18 Shakeproof.....	1	009552-400	
105	Pin, Groove, 3/16 x 3/4".....	1	007900-400	
106	Pin, Groove, 5/64 x 5/8".....	1	009593-400	
107	Pitot.....	1	072186-001	
108	Plate.....	1	512714-001	
109	Ring, Retaining.....	1	064150-001	
110	@4 Rotor and Blade Assembly:			
	Previous Design (Prior to 1973):			
	Standard.....	1	515706-001	
	All Iron.....	1	515706-002	
	Current Design (1973 to present):			
	Standard.....	1	517231-001	
	All Iron.....	1	517231-002	
	LPG.....	1	517231-003	
111	Arm, Locating.....	1	511945-001	
112	+ Bearing, Rotor:			
	Standard and All Iron.....	2	516109-001	
	LPG.....	2	516109-002	
113	+ Bearing, Thrust:			
	Standard and All Iron.....	1	006519-001	
	LPG.....	1	504658-001	
114	+ Blade, Lower:			
	Standard.....	1	008901-001	
	All Iron.....	1	009441-042	
	LPG.....	1	504662-001	
	Standard – Modified for 2,000 SSU to 10,000 SSU.....	1	008901-041	
	Standard – Modified for 200°F Max.....	1	008901-042	
	Standard – Modified for 2,000 SSU to 10,000 SSU and 200°F Max.....	1	008901-043	
	A.I. – Modified for 2,000 SSU to 10,000 SSU.....	1	009441-041	
115	Pin, Blade Roller.....	2	003449-001	
116	Pin, Cotter, 3/32 x 1".....	2	006308-001	
117	+ Roller, Blade:			
	Standard and All Iron.....	2	065109-001	
	LPG.....	2	644412-402	
118	+ Blade, Upper:			
	Standard.....	1	008900-001	
	All Iron.....	1	009441-042	
	LPG.....	1	504663-001	
	Standard – Modified for 2,000 SSU to 10,000 SSU.....	1	008900-041	
	Standard – Modified for 200°F Max.....	1	008900-042	
	Standard – Modified for 2,000 SSU to 10,000 SSU and 200°F Max.....	1	008900-043	

Item	Description	Qty.	Part Number
	A.I. – Modified for 2,000 SSU to 10,000 SSU.....	1	009442-041
119	Pin, Blade Roller.....	2	003449-001
120	Pin, Cotter, 3/32 x 1".....	2	006308-001
121	+ Roller, Blade:		
	Standard and All Iron.....	2	065109-001
	LPG.....	2	644412-402
122	Clamp, Rotor Cover Roller.....	8	011226-001
123	Clamp, Thrust Bearing.....	1	512074-001
124	Key.....	1	512715-001
125	Nut, Adjusting Screw.....	1	003527-001
126	Pin, Adjusting Screw Extension.....	1	512073-001
127	Pin, Rotor Cover Roller.....	4	001634-001
128	Pin, Thrust Bearing Collar.....	1	008251-001
129	Plate, Rotor Gear.....	1	512112-001
130	Rotor:		
	Standard.....	1	008253-002
	Old Style w/Drilled Holes.....	1	008253-191
	Standard – Modified for 2,000 SSU to 10,000 SSU.....	1	008253-041
	LPG and Standard – Modified for 200°F Max.....	1	008253-042
	Standard – Modified for 2,000 SSU to 10,000 SSU and 200°F Max.....	1	008253-043
131	Screw, 1/4-20 x 7/8".....	12	006100-002
132	+ Roller, Rotor Cover:		
	Standard and All Iron.....	4	011681-001
	LPG.....	4	514751-001
133	Screw, Adjusting.....	1	003526-002
134	Screw, Locating Arm, 5/16-18 x 1-1/4".....	1	643764-402
135	Screw, Rotor Gear Plate, 1/4-20 x 7/8".....	4	006100-002
136	+@4 Shaft and Cam Assembly:		
	Pre-2008.....	1	512113-001
	2008-Present.....	1	517152-001
137	@4 Cam:		
	Pre-2008.....	1	003814-001
	2008-Present.....	1	517019-001
138	Key:		
	2008-Present.....	1	005535-800
139	Shaft.....	1	511876-001
140	Spacer, Bearing.....	1	512075-001
141	+ Spring, Rotor Bearing.....	1	002198-002
142	Screw, 5/16-18 x 1".....	1	006325-002
143	Screw, #10-32 x 1-1/2".....	2	009606-400
144	Screw, Cap (Block) 1/2-13 x 1".....	2	010525-400
145	Screw, Inner Cover to Body.....	8	006140-002
146	Screw, Nylok.....	1	641044-401
147	Shaft, Jack and Gear Assembly.....	1	512062-001
148	Washer.....	1	643249-401
149	* Washer, Lock #10.....	2	642482-406
150	Washer, Special.....	1	065309-002

Inner Mechanism General Assembly Numbers

Standard.....	517153-091
All Iron.....	517153-092
LPG.....	517153-093

- + Recommended spares.
- * Not Illustrated.
- R Indicates change since last revision.
- @1 Note 1: When ordering, include temperature range and specific API gravity.
- @2 Note 2: Only standard gearing is listed. For additional gearing combinations, see Gear Train Bulletin AB01023.
- @3 Note 3: See Form No. PO01042 for components (PG-15 – Prior to 2008, PG-30 – After 2008).
- @4 Note 4: In 1973 a change in design was made to the block and cam of the four-inch meter. To ensure proper operation, a current style block must be used with a current style cam. Either current or previous style block can be used with previous style cam. The shaded area of the block outline below represents the dimensioning of the previous style.
- @5 Note 5: A1 Housing is not available as a new replacement part. Please contact Guidant for a remanufactured replacement.
- @6 Note 6: Pre-2008 not illustrated

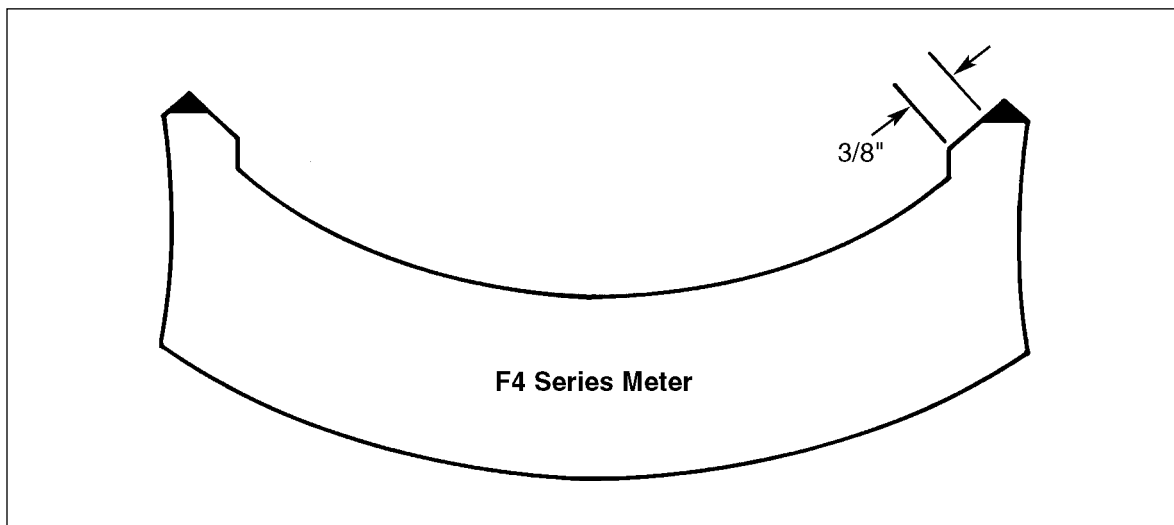

Technical Support

Contact Information:

Field Service Response Center

24/7 Technical Support/Schedule a
Technician: 1-844-203-4014 System
Installation Supervision, Start-Up,
Training, and Commissioning
Services Available

The specifications contained herein are subject to change without notice and any user of said specifications should verify from the manufacturer that the specifications are currently in effect. Otherwise, the manufacturer assumes no responsibility for the use of specifications which may have been changed and are no longer in effect.

USA Operation
1602 Wagner Avenue
Erie, Pennsylvania 16510 USA
P:+1 814.898.5000

Germany Operation
Smith Meter GmbH
Regentstrasse 1
25474 Ellerbek, Germany
P:+49 4101 304.0