

3" Steel Model E3

Bulletin SS01016 Issue/Rev. 1.3 (11/21)

Smith Meter® PD Meters

The Smith Meter Model E3 is a 3", double-case, straight-through (S3 through S8), rotary vane type positive displacement meter. Applications for the E3 include blending, batching, dispensing, inventory control, and custody transfer of oils, solvents, chemicals, paints, fats and fertilizers.



Features

- Superior accuracy—Smith Meter's rotary-vane meter principle, combined with the meter's uniquely designed (offset) inlet and outlet nozzles, maximizes accuracy by minimizing pressure drop across the measuring chamber reducing slippage (flow through meter clearances).
- Low pressure drop—Streamlined flow path provides low pressure drop.
- Positive and accurate registration—High-torque drive calibrator with adjustment in 0.05 percent (%) increments ensures accurate registration.
- Long service life—Low-friction ball bearings, fixed cam-type timing, and rugged construction provide sustained accuracy and long service life.

Options

- High-viscosity meter clearances extend operation at maximum flow rate from 400 to 2,000 millipascal-second (mPa•s).
- High-temperature clearances extend operating temperatures from 150 to 200 degrees Fahrenheit (°F) (65 to 93 degrees Celsius (°C)).
- All iron trim option for operating temperatures above 200 °F (93 °C).
- Liquefied petroleum gas (LPG) trim option for low-lubricity liquids, such as LPG.
- Compliant with NACE standard MR0175.
- ASME Section VIII vessel construction is available for model E3-S3.

Operating Specifications

Maximum Flow Rate

	USGPM	L/min
Continuous rating with standard trim	420	1,600
Intermittent rating¹ with standard trim	500	1,900
Continuous/intermittent rating with all iron or LPG trim	315	1,200

Minimum Flow Rate (Typical Performance)

Linearity ²	Units	Viscosity (Centipoise—mPa•s)					
		.5	1	5	20	100	400
±0.15%	USGPM	80	50	20	5	1	0.25
	L/min	303	190	75	19	4	1
±0.25%	USGPM	50	35	15	4	0.8	0.20
	L/min	190	132	57	15	3	0.8
±0.50%	USGPM	40	25	10	2.4	.05	0.13
	L/min	150	95	38	10	2	0.5

US gallons per minute (USGPM) and liters per minute (L/min)

1 Intermittent rating applies to service on clean, refined products where continuous operation is not required (for example, truck loading, rail loading, and other batching applications).

2 Linearity based on a maximum flow rate of 420 USGPM (1,600 L/min) unless otherwise stated.

Repeatability

±0.02%

Viscosity

Standard: 400 mPa·s³ (2,000 Seconds Saybolt Universal (SSU)) maximum

Optional: 2 pascal seconds (Pa·s) (10,000 SSU) maximum and specify "High Viscosity Meter Clearances"

Over 2 Pa·s: Specify "High Viscosity Meter Clearances" and derate maximum flow rate in direct proportion to viscosity over 2 Pa·s. For example, at 4 Pa·s, derate maximum flow rate to 50% of normal continuous rating 210 USGPM.

Temperature

Standard meter clearances with:

Buna-N/PTFE ⁸ :	-20 to 150 °F (-29 to 65 °C)
FKM ⁹ :	10 to 150 °F (-12 to 65 °C)
Low temp. FKM ^{9,10} :	-50 to 150 °F (-46 to 65 °C)

High temperature meter clearances with:

Buna-N/PTFE ⁸ :	-20 to 200 °F (-29 to 93 °C)
FKM ⁹ :	10 to 200 °F (-12 to 93 °C)
Low temp. FKM ^{9,10} :	-50 to 200 °F (-46 to 93 °C)

All iron trim with:

Buna-N:	-20 to 225 °F (-29 to 108 °C)
PTFE ⁸ :	-20 to 400 °F (-29 to 205 °C)
FKM ⁹ :	10 to 400 °F (-12 to 205 °C)
Low temp. FKM ^{9,10} :	-50 to 400 °F (-46 to 205 °C)

Meter Gearing

Five US gallons or 1 dekaliter per revolution of meter calibrator output shaft.

One barrel—special.

Maximum Working Pressure

Model	Flange	PSI	kPa ⁷
E3-S3	150	285 ⁴	1,965 ⁴
E3-S6	300	740 ⁴	5,102 ⁴
E3-S7	600	1,480 ⁴	10,204 ⁴
E3-S8	900	2,220 ⁴	15,306 ⁴

Note: Flange class per ANSI B16.5 raised-face flange.

Pressure Drop (ΔP)

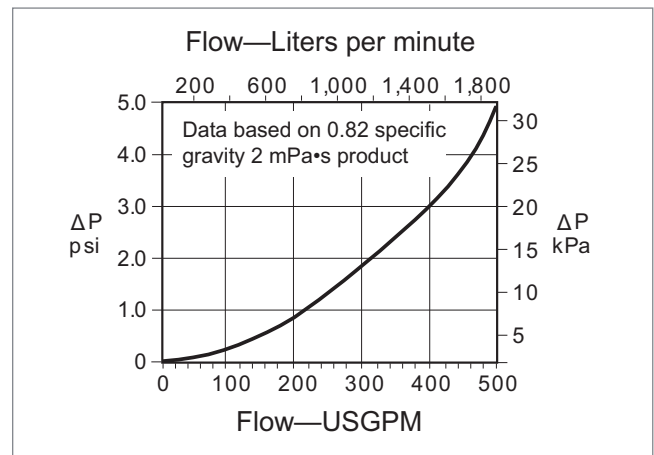

Materials of Construction

Trim	Housing	Internals	Seals
Standard	Steel	Iron, steel, stainless steel, aluminum	Buna-N ⁶ , FKM ^{5,9} , PTFE ⁸ , low temp. FKM ¹⁰
LPG	Steel	Iron, steel, stainless steel, aluminum, rulon, and nylon	Buna-N ⁶ , FKM ^{5,9} , PTFE ⁸ , low temp. FKM ¹⁰
All Iron	Steel	Iron, steel, stainless steel	Buna-N ⁶ , FKM ^{5,9} , PTFE ⁸ , low temp. FKM ¹⁰

Installation

It is recommended that the meter be protected with a suitable mesh strainer.

Weights and Measures Approvals

NTEP Certificate of Conformance 95-054
 Canadian Notice of Approval (NOA) S.WA-0615
 Australia—NMI 5-6B-55B
 Brazil INMETRO Dimel No. 0148
 PTB Issued MID (Measuring Instrument Directive)
 PTB Issued OIML R117 Test Report
 Russia—GOST
 For others, consult factory.

Pressure Safety Requirements

PED—Pressure Equipment Directive (Europe)
 CRD—Canadian Registration Number
 For others, consult factory.

³ 1,000 mPa·s = 1,000 cP = 1 Pa·s.

⁴ Maximum working pressure at 100 °F (38 °C)

⁵ All S3 through S8 meters with FKM trim have PTFE packing gland seals.

⁶ Standard

⁷ See catalog code for more options.

⁸ Polytetrafluoroethylene (PTFE)

⁹ Fluoroelastomer (FKM)

¹⁰ Only available for E3-S3 with low temperature material and ASME Section VIII design. Low temperature FKM is the standard sealing material for meters with the ASME Section VIII design.

Catalog Code

The following guide defines the correct PD meter for a given application and the respective catalog code. This code is part of the ordering information and should be included on the purchase order.

1	2	3	4	5	6	7	8	9	10
K	E	3	S	1	G	B	S	0	0

Position 1: Code

K—Catalog Code

Positions 2 and 3: Model/Flange Size

E3—3"

Position 4: Flow Path

S—Straight

Position 5: Pressure Class and End Connections

Standard (Raised-Face Flanges)

- 3—Class 150, 285 psig/1,965 kPa
- 6—Class 300, 740 psig/5,102 kPa
- 7—Class 600, 1,480 psig/10,204 kPa
- 8—Class 900, 2,220 psig/15,306 kPa

PED (Raised-Face Flanges)

- 1—Class 150, not available
- 3—Class 150, 285 psig/1,965 kPa
- 5—Class 300, not available
- 6—Class 300, 740 psig/5,102 kPa
- 7—Class 600, consult factory

All Flanges designed to ANSI B16.5, pressure ratings maximum working pressure at 100 °F.

Position 6: Meter Gearing

- G—Gallons (5:1 - S3)
- B—Barrels (1:1 - S3 through S8)
- D—Dekaliters (1:1 - S3 through S8)
 - I—Imperial Gallons¹¹
 - P—Pound¹¹

Position 7: Seals

- B—Buna-N
- V—FKM⁹
- T—PTFE⁸
- L—Low temp. FKM^{9,10}

Position 8: Trim

- S—Standard
- A—All Iron
- L—LPG

Position 9: Temperature Compensation

- 0—None
- A—ATC
- B—ATG

Position 10: Special Requirements

- 0—Standard
- P—PED (consult factory)¹²
- C—CRN and low temp. material¹⁰
- L—Low temp. material¹⁰

⁸ Polytetrafluoroethylene (PTFE).

⁹ Fluoroelastomer (FKM).

¹⁰ Only available for E3-S3 with low temperature material and ASME Section VIII design. Low temperature FKM is the standard sealing material for meters with the ASME Section VIII design.

¹¹ Consult factory for model number when selecting imperial or pound gearing.

¹² PED required for all European countries. The equipment must be manufactured by Ellerbek, Germany facility.

Dimensions

Inches (millimeters)

Note: Dimensions—Inches to the nearest tenth (millimeters to the nearest whole mm), each independently dimensioned from respective engineering drawings.

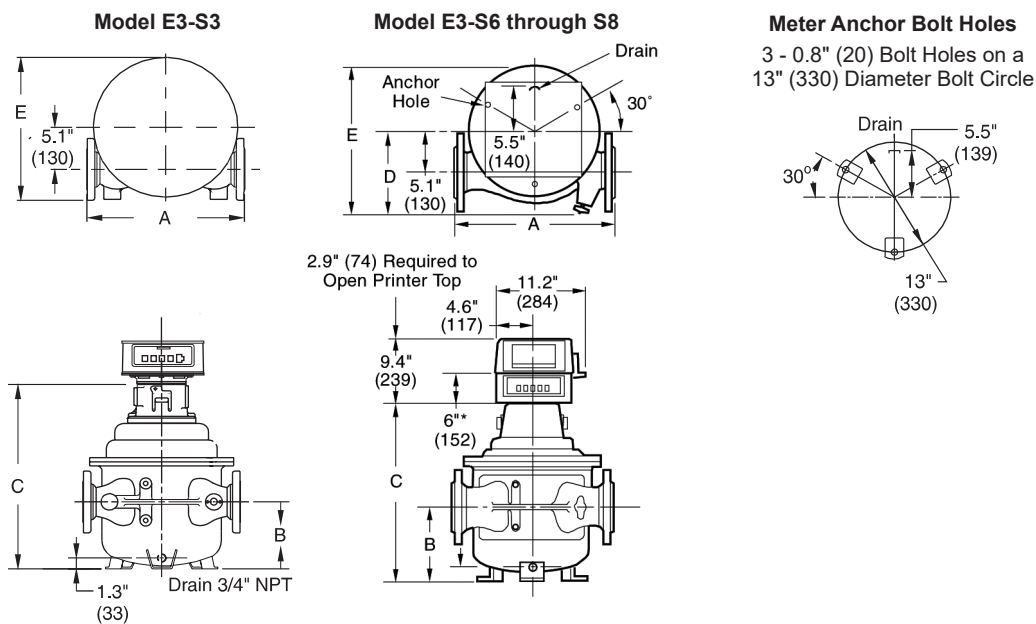

Model	A	B	C	D	E	Weight—lb (kg)
E3-S3	18.5" (470)	8.1" (206)	22.5" (572)	8.9" (226)	17.8" (451)	270 (122)
E3-S3 low temp. material	18.5" (470)	8.1" (206)	22.7" (577)	8.9" (226)	17.8" (451)	394 (179)
E3-S6	23.0" (584)	8.5" (216)	25.0" (635)	9.3" (236)	18.7" (475)	435 (197)
E3-S7	23.3" (592)	8.8" (224)	25.8" (655)	9.3" (236)	19.4" (492)	660 (299)
E3-S8	27.3" (691)	15.8" (400)	33.9" (860)	14.0" (355)	28.0" (711)	1,265 (573)

Ordering Information

Application	Batching, Loading, Blending, Inventory, Process Control, etc.
Operating Conditions	Liquid—Name, Specific Gravity or API Gravity, Flow Range ¹³ , Temperature Range ¹³ , Viscosity Range ¹³ , Maximum Working Pressure
Seals	Buna-N ¹⁴ , FKM ⁹ , PTFE ⁸ , or Low temp. FKM ^{9,10} .
Units of Registration	Gallons, Barrels, Liters, Dekaliters, Pounds, Kilograms, etc.
Direction of Flow	Left-to-right (as viewed above) is standard and will be supplied unless right-to-left flow is specified.
Style	Straight-through
Options and Accessories	As required

8 Polytetrafluoroethylene (PTFE).

9 Fluoroelastomer (FKM).

10 Only available for E3-S3 with low temperature material and ASME Section VIII design. Low temperature FKM is the standard sealing material for meters with the ASME Section VIII design.

13 Specify minimum/normal/maximum.

14 Standard seals supplied unless optional material specified.

Accessories

Strainer

- 3" steel, raised-face (RF) flanged

Mechanical Preset Valves

- 3" straight-through type, steel, flanged, 300 pounds per square inch (psi) maximum working pressure

Hydraulic Valves

- 3" globe-type, steel, RF flanged, 300 psi maximum working pressure

Air Eliminator

- 3" steel, RF flanged, 300 psi maximum working pressure

Counters

- 200 Series—Accumulative, nine-digit, non-reset type
- 600 Series—Five large digit reset, eight small digit non-reset

Printer

- Seven-digit accumulative
- Optional six-digit zero start

Preset Counter

- 300C Series—Four-digit (five-digit optional) mechanical pushbutton preset with valve linkage
- Microswitch package for hydraulic valve, pump control, or other interlock is optional

Pulse Transmitters

- Universal pulse transmitter (UPT)—Quad-channel, infrared, security pulse transmitter in an explosion-proof housing (up to 1,000 pulses/revolution)
- Large number counters (LNC) pulse transmitter (adapts to 600 Series counters)
 - Low-resolution—1 to 10 pulses¹⁵
 - High-resolution—50 or 100 pulses¹⁵

Flow Rate Indicator

- Direct-mount mechanical
- Remote electronic

Remote Registration

- Electro-mechanical counters
- Electronic totalizers

Automatic Temperature Compensation Models

- Automatic Temperature Compensator (ATC)—Factory-set for a given product
- Automatic Temperature Gravity (ATG)—Field-adjustable for different products

¹⁵ Per revolution of LNC right-hand wheel.

Revisions included in SS01016 Issue/Rev. 1.3 (11/21):

E3-S3 ASME Section VIII low temperature material information added.

The specifications contained herein are subject to change without notice and any user of said specifications should verify from the manufacturer that the specifications are currently in effect. Otherwise, the manufacturer assumes no responsibility for the use of specifications which may have been changed and are no longer in effect.

USA Operation
1602 Wagner Avenue
Erie, Pennsylvania 16510 USA
P:+1 814.898.5000

Germany Operation
Smith Meter GmbH
Regentstrasse 1
25474 Ellerbek, Germany
P:+49 4101 304.0