

# Vertical Basket Strainer

## TYPE FV for horizontal pipe run

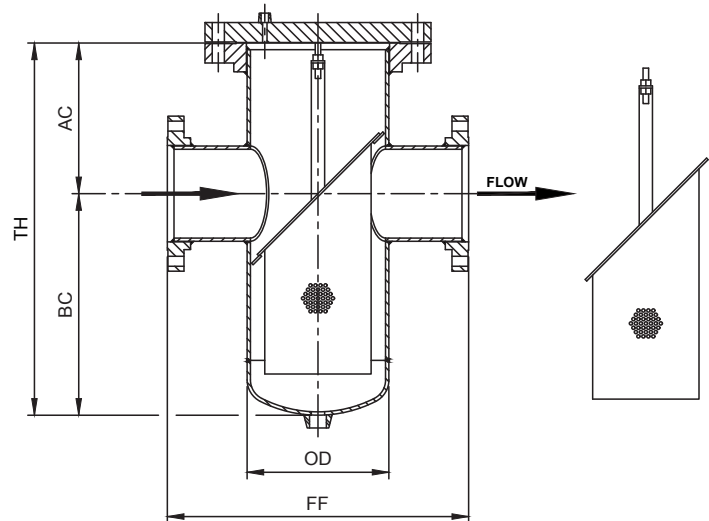

- All dimensions are in inches and based on an ASME flanged closure
- Dimensions shown are good through 600# ASME
- Standard design is based on ASME B31.4
- Many quick opening closure options are available (see Bulletin OA-112)
- Open area ratios are based on using a 40% open area basket media (see Bulletin AC-112)
- Larger line sizes and custom designs are available

LINE SIZE (IN.)	BODY OD	COMMON DIMENSIONS (IN.)						DRAIN	VENT	APPROXIMATE OPEN AREA RATIO	LINE SIZE (IN.)
		FF	BC	ASME 150# / 300#		ASME 600#					
				TH	AC	TH	AC				
2	4 1/2	17	9	16	7	16	7	1	1/4	525%	2
3	6 5/8	20	11	20	9	20	9	1	1/4	450%	3
4	8 5/8	23	14	24	10	24	10	1 1/2	1/2	600%	4
6	10 3/4	26	17	29	12	29	12	1 1/2	1/2	425%	6
8	12 3/4	30	21	35	14	37	16	1 1/2	1/2	375%	8
10	16	34	25	42	17	45	20	1 1/2	1/2	375%	10
12	18	37	28	46	18	50	22	2	1/2	350%	12
14	18	37	33	53	20	57	24	2	1/2	350%	14
16	24	44	36	60	24	62	26	2	1/2	400%	16
18	24	45	39	65	26	67	28	2	1/2	350%	18
20	26	48	45	71	26	76	31	2	1/2	350%	20
24	30	56	64	94	30	100	36	2	1/2	400%	24
30	36	66	71	106	35	115	44	2	1/2	350%	30

### Minimum Information Required for RFQ (see Strainer Bulletins SD-118 and SI-112 for assistance)

1. Quantity
2. Line size
3. ASME flange rating or beveled for welding
4. Design pressure, temperature & flow rate
5. Piping design code (ASME B31.4 is standard)
6. Basket media size (see Bulletin AC-112)
7. Housing and basket material (carbon steel is standard)
8. Other special requirements or specifications (paint, etc)

# Estimated Pressure Drop with Clean Basket

## TYPE FV for horizontal pipe run

Note: All pressure drops offered are estimates based on a clean basket and can vary due to basket blockage, location of blockage, flow dynamics, etc..

Based on basket media of 40% open area.

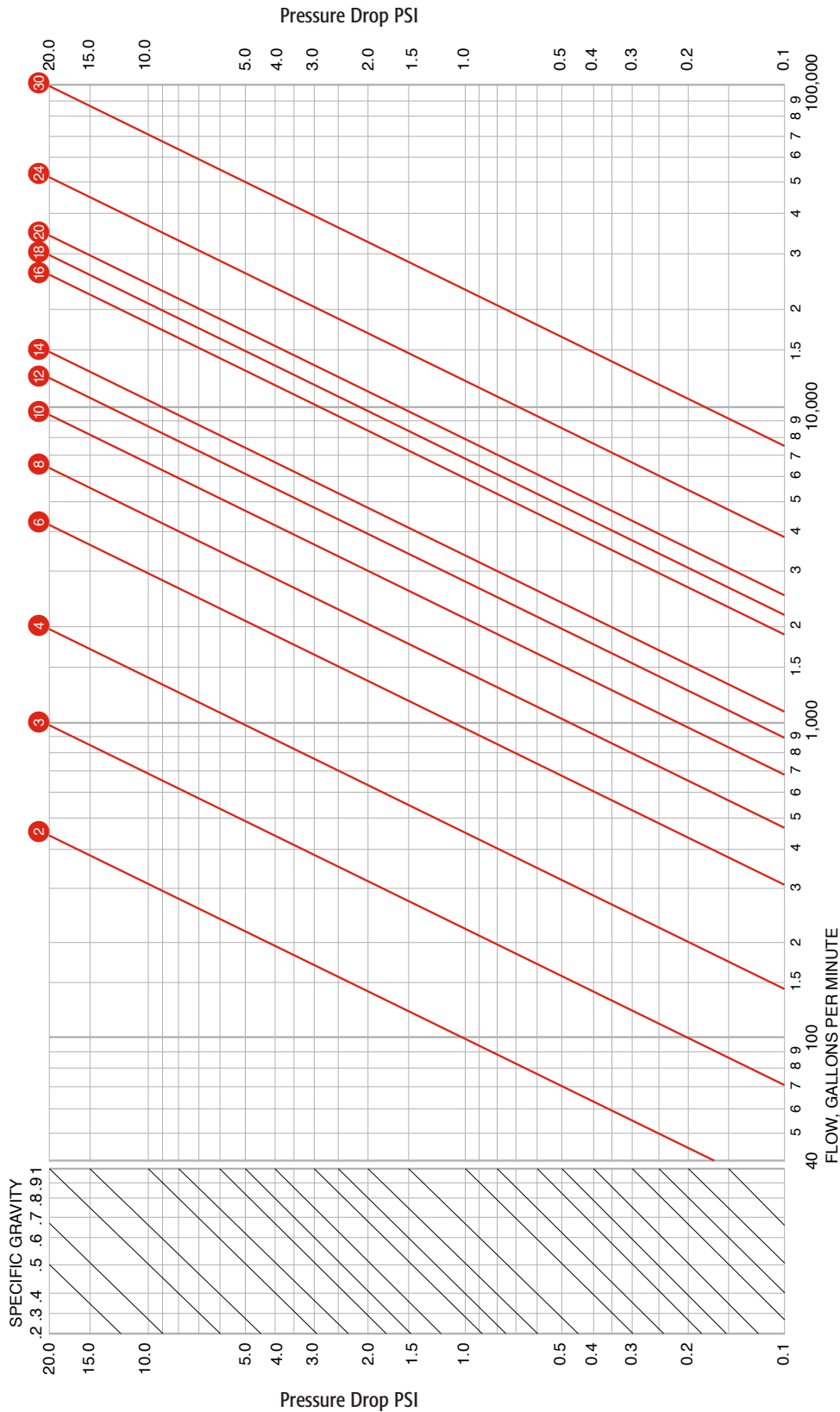

### EXAMPLE: A 6" line flowing 1,000 GPM liquid with a specific gravity of 0.6.

To find the pressure drop, enter the chart at 1,000 GPM and intersect the line representing a 6" FV strainer. Read to the left to intersection of SG = 1. Follow diagonal guide lines down to SG = 0.6. Read straight to the left for the corrected pressure drop. In the example, the FV strainer would have a pressure drop of 0.7 PSID. The strainer section would depend upon piping configuration and allowable pressure drop.

### CORRECTION FACTORS - MULTIPLY PRESSURE DROP BY:

VISCOSITY SSU	BASKET MEDIA OF 40% OPEN AREA		
	USE CHART	WITH WIRE MESH LINER	
30 (WATER)	1.3	60 MESH	100 MESH
500	1.6	80 MESH	1.7
1,000	1.7	1.6	2.4
2,000	1.9	2.1	2.6
	2.2	2.4	2.8
	2.4	2.7	3.2

# Materials Data

## Perforated, Expanded Metal and Wire Cloth Media

### Perforated patterns normally stocked

PATTERN		% OPEN AREA	# HOLES PSI	MATERIAL/GAUGE		
DIA	CENTERS			C.S.	304SS	316SS
1/8	3/16	40	33	14,11	14	14
3/16	1/4	51	18	14	16	16
1/4	3/8	40	8	11	14,11	14,11
3/8	9/16	40	3,7	11	11	-
1/2	11/16	48	2,4	11	11	-

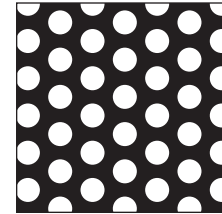

1/8" DIA. on 3/16" CTR

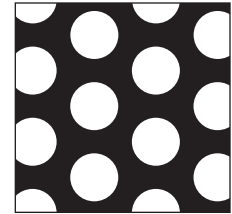

1/4" DIA. on 3/8" CTR

### Expanded metal normally stocked

For straining or fine mesh wire cloth support

SIZE	TYPE	% OPEN AREA	MATERIAL	
			C.S.	304SS
1/2	Flattened	62	16	16
3/4	Flattened	72	13	13



1/2" Expanded

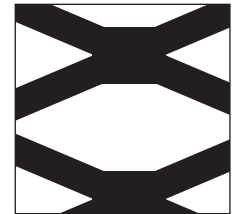

3/4" Expanded

### Wire cloth normally stocked

Coarse mesh for straining or support

MESH*	WIRE DIA.	OPENING	MICRONS	% OPEN AREA
3 x 3	.080	.2533	6429	57.6
4 x 4	.063	.1870	4746	56.0
8 x 8	.035	.0900	2284	51.8
8 x 8	.047	.0780	1980	38.9
10 x 10	.035	.0650	1650	42.3

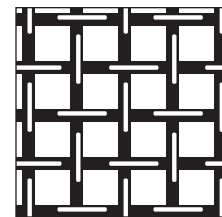

4 x 4 Mesh

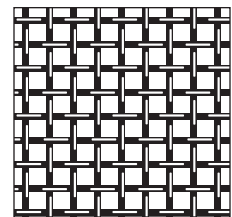

8 x 8 Mesh

Fine mesh requiring support

MESH*	WIRE DIA.	OPENING	MICRONS	% OPEN AREA
20 x 20	.016	.0340	863	46.2
30 x 30	.012	.0213	541	41.0
40 x 40	.010	.0150	381	36.0
60 x 60	.0075	.0092	234	30.5
80 x 80	.0055	.0070	178	31.4
100 x 100	.0045	.0055	140	30.3

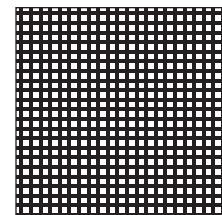

20 x 20 Mesh

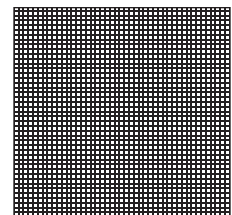

40 x 40 Mesh

\*Number of wires per linear inch. All meshes shown are available, in 304SS and 316SS. Other meshes and materials are available upon request. All dimensions in inches. C.S. = Carbon Steel

Linear Equivalents:  
 1 micron = .0000394 inches  
 25,400 microns = 1 inch  
 See Bulletin TG-112 for a comparative chart.

# Optional Accessories for Strainers

These illustrations represent just some of the quick opening closure types used.



**Threaded Closure**

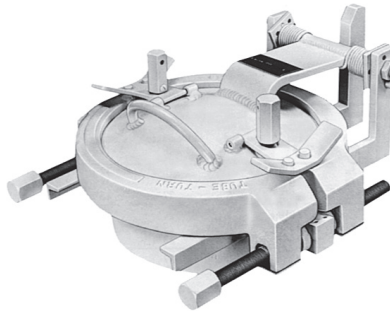

**Double Bolt Closure**

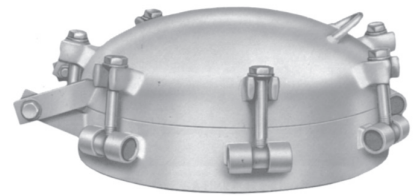

**T-Bolt Hinged Closure**

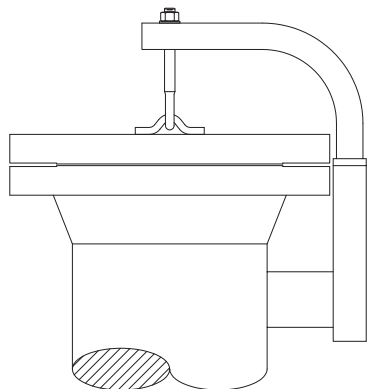

**Davit for Blind Flange Closure**

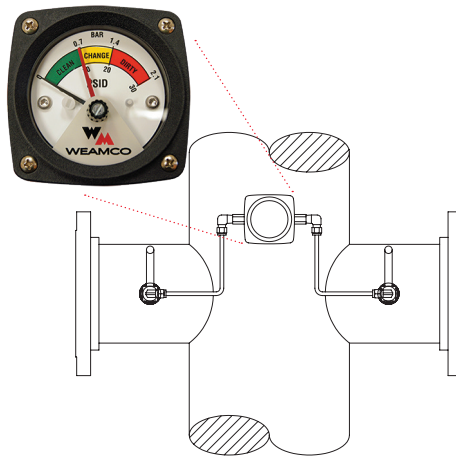

**DP Gauge Assembly**

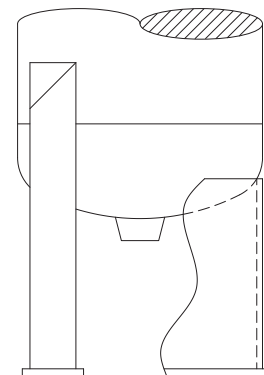

**Legs or Base Skirt**

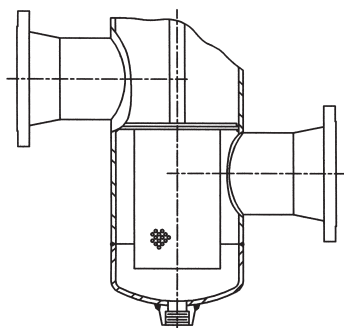

**Flat Top Basket Offset Nozzles**

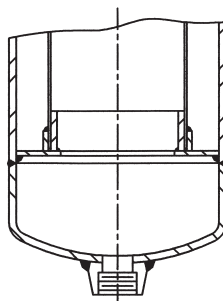

**Blowdown Basket**

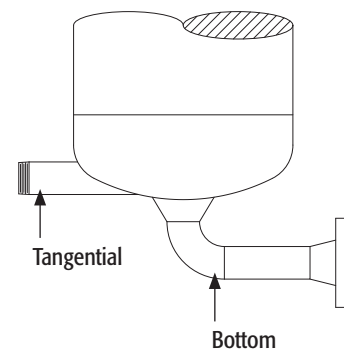

**Side Drains**

# Estimated Strainer Weights

## Based on catalog standards units

(See Bulletins FV-112, FT-112 and TEE-112)

FV AND FT STRAINERS					
2"-150#	3"-150#	4"-150#	6"-150#	8"-150#	10"-150#
70#	120#	190#	295#	470#	735#
2"-300#	3"-300#	4"-300#	6"-300#	8"-300#	10"-300#
100#	185#	275#	440#	660#	1070#
2"-600#	3"-600#	4"-600#	6"-600#	8"-600#	10"-600#
130#	260#	430#	765#	1085#	1880#

FV AND FT STRAINERS					
12"-150#	14"-150#	16"-150#	18"-150#	20"-150#	24"-150#
905#	1015#	1595#	1685#	2180#	3150#
12"-300#	14"-300#	16"-300#	18"-300#	20"-300#	24"-300#
1390#	1650#	2780#	3025#	3620#	5685#
12"-600#	14"-600#	16"-600#	18"-600#	20"-600#	24"-600#
2360#	2720#	4640#	4955#	5955#	10255#

TEE STRAINERS					
2" 150#	3" 150#	4" 150#	6" 150#	8" 150#	10" 150#
W-18#	W-33#	W-54#	W-102#	W-161#	W-235#
F-30#	F-56#	F-87#	F-154#	F-245#	F-343#
2" 300#	3" 300#	4" 300#	6" 300#	8" 300#	10" 300#
W-26#	W-52#	W-79#	W-147#	W-231#	W-355#
F-42#	F-88#	F-132#	F-237#	F-369#	F-555#
2" 600#	3" 600#	4" 600#	6" 600#	8" 600#	10" 600#
W-32#	W-58#	W-111#	W-235#	W-376#	W-609#
F-52#	F-94#	F-185#	F-381#	F-600#	F-987#

TEE STRAINERS					
12" 150#	14"-150#	16" 150#	18"-150#	20"-150#	24"-150#
W-362#	W-458#	W-577#	W-699#	W-904#	W-1317#
F-538#	F-686#	F-861#	F-1029#	F-1298#	F-1853#
12" 300#	14"-300#	16" 300#	18"-300#	20"-300#	24"-300#
W-508#	W-691#	W-862#	W-1093#	W-1356#	W-2055#
F-792#	F-1103#	F-1360#	F-1705#	F-2094#	F-3093#
12" 600#	14"-600#	16" 600#	18"-600#	20"-600#	24"-600#
W-787#	W-1100#	W-1460#	W-1767#	W-2291#	W-3155#
F-1239#	F-1794#	F-2422#	F-2877#	F-3671#	F-5109#

# Basket Strainer Data Sheet



Customer \_\_\_\_\_ Date \_\_\_\_\_  
 Contact \_\_\_\_\_ RFQ/PO \_\_\_\_\_  
 Email \_\_\_\_\_ Project \_\_\_\_\_  
 Phone \_\_\_\_\_ Location \_\_\_\_\_  
 Address \_\_\_\_\_ End User \_\_\_\_\_

**FOR RFQ – PLEASE PROVIDE ALL AVAILABLE INFORMATION**

Quantity	Weamco Type	Tag Number
Service		
Flow Rate (Max)	<input type="checkbox"/> GPM <input type="checkbox"/> BPH <input type="checkbox"/> MMSCFM	
Specific Gravity	Allowable Pressure Drop (Clean)	psid
Design Code	<input type="checkbox"/> B31.3 <input type="checkbox"/> B31.4	
	<input type="checkbox"/> B31.8 w/Design Factor <input type="checkbox"/> 0.50 <input type="checkbox"/> 0.60 <input type="checkbox"/> 0.72	
	<input type="checkbox"/> ASME Sect. VIII, Div.1 U-Stamp <input type="checkbox"/> Yes <input type="checkbox"/> No	
Design Conditions	Pressure psig	Temp °F
	MDMT °F	CA in
Housing Material	<input type="checkbox"/> Carbon Steel <input type="checkbox"/> 304SS <input type="checkbox"/> 316SS <input type="checkbox"/> Other	
Strainer Closure Type	<input type="checkbox"/> Blind Flg With Davit <input type="checkbox"/> Yes <input type="checkbox"/> No	
	<input type="checkbox"/> Quick Opening Closure and O-Ring Material	
List Type:	<input type="checkbox"/> Clamp-On <input type="checkbox"/> T-Bold <input type="checkbox"/> Thread-On	
Basket Media Material	<input type="checkbox"/> Carbon Steel <input type="checkbox"/> 304SS <input type="checkbox"/> 316SS <input type="checkbox"/> Other (Specify:)	
Basket Media Size	(See Bulletin AC-112)	
Basket Liner Material	<input type="checkbox"/> None <input type="checkbox"/> 304SS <input type="checkbox"/> 316SS <input type="checkbox"/> Other (Specify:)	
Basket Liner/Mesh Size	(See Bulletin AC-112)	
AML	If Yes, (Specify:)	
Additional Specifications	If Yes, (Specify:)	

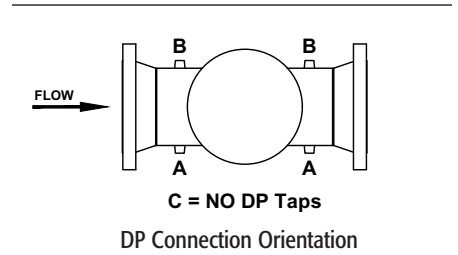
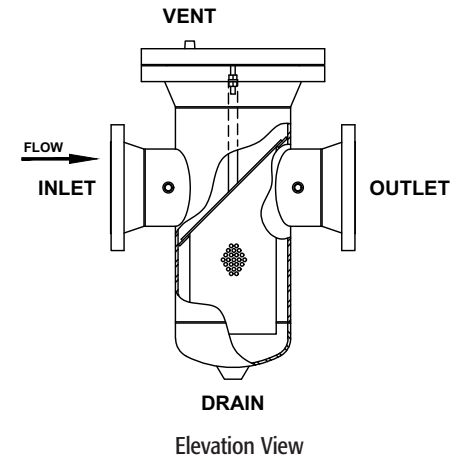

CONNECTIONS	SIZE	RATING	FACE
Inlet			
Outlet			
Vent			
DP Taps			
Drain			
If Side Drain:	<input type="checkbox"/> Bottom <input type="checkbox"/> Tangential	(See Bulletin OA-112)	
DP Gauge Assembly	<input type="checkbox"/> Yes <input type="checkbox"/> No		

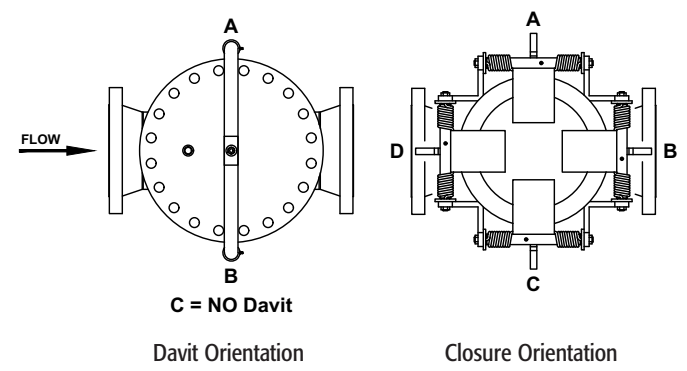

NACE Req'd	<input type="checkbox"/> Yes <input type="checkbox"/> No
DOT	<input type="checkbox"/> Yes <input type="checkbox"/> No
Interior Finish/Coating	
Exterior Finish/Coating	<input type="checkbox"/> Standard - SP3 with Universal Primer
	<input type="checkbox"/> Other (Specify:)

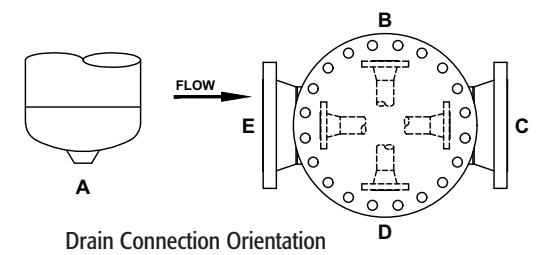

(See Strainer Bulletin SI-112 for assistance.)

Drawing Req'd	<input type="checkbox"/> For Approval <input type="checkbox"/> For Record Only
Submit Drawings to:	
Email Address:	

**Notes:**

---



---



---