

Daniel™ Model 700 Control Valve

NPS 2 through 16 / Class 150-600



Safety and approval information

This Daniel product complies with all applicable European directives when properly installed in accordance with the instructions in this manual. Refer to the EU declaration of conformity for directives that apply to this product. The EU declaration of conformity, with all applicable European directives, and the complete ATEX Installation Drawings and Instructions are available on the internet at www.emerson.com or through your local Daniel support center.

Information affixed to equipment that complies with the Pressure Equipment Directive, can be found on the internet at <http://www.emerson.com>.

For hazardous installations in Europe, refer to standard EN 60079-14 if national standards do not apply.

Other information

Full product specifications can be found in the product data sheet. Troubleshooting information can be found in the user manual. Product data sheets and manuals are available from the Daniel web site at <http://www.emerson.com>.

Return policy

Follow Emerson procedures when returning equipment. These procedures ensure legal compliance with government transportation agencies and help provide a safe working environment for Emerson employees. Emerson will not accept your returned equipment if you fail to follow Emerson procedures. Return procedures and forms are available on our web support site at www.emerson.com, or by phoning the Emerson Customer Service department.

Emerson Flow customer service

Email:

- Worldwide: flow.support@emerson.com
- Asia-Pacific: APflow.support@emerson.com

Telephone:

North and South America		Europe and Middle East		Asia Pacific	
United States	800-522-6277	U.K.	0870 240 1978	Australia	800 158 727
Canada	+1 303-527-5200	The Netherlands	+31 (0) 704 136 666	New Zealand	099 128 804
Mexico	+41 (0) 41 7686 111	France	0800 917 901	India	800 440 1468
Argentina	+54 11 4837 7000	Germany	0800 182 5347	Pakistan	888 550 2682
Brazil	+55 15 3413 8000	Italy	8008 77334	China	+86 21 2892 9000
		Central & Eastern	+41 (0) 41 7686 111	Japan	+81 3 5769 6803
		Russia/CIS	+7 495 981 9811	South Korea	+82 2 3438 4600
		Egypt	0800 000 0015	Singapore	+65 6 777 8211
		Oman	800 70101	Thailand	001 800 441 6426
		Qatar	431 0044	Malaysia	800 814 008
		Kuwait	663 299 01		
		South Africa	800 991 390		
		Saudi Arabia	800 844 9564		
		UAE	800 0444 0684		

Contents

Part I	Plan	
Chapter 1	Introduction.....	7
	1.1 Purpose of this manual.....	7
	1.2 Hazard messages.....	7
	1.3 Personnel qualifications.....	7
	1.4 Warranty restrictions.....	9
	1.5 Assistance.....	9
	1.6 Description of the Model 700 Control Valves.....	9
	1.7 Agency certifications for control valves Model 700.....	18
Chapter 2	Operating conditions and specifications.....	19
	2.1 Operating conditions for the control valve.....	19
	2.2 Specifications for the control valve.....	23
Chapter 3	Control valve handling.....	27
	3.1 Receive the control valve.....	27
	3.2 Store the control valve.....	27
Chapter 4	Prepare the control valve for use.....	29
	4.1 Lifting conditions.....	29
	4.2 Lifting requirements for personnel.....	30
	4.3 Configure the control valve.....	32
Part II	Install	
Chapter 5	Installation prerequisites.....	37
	5.1 Pre-start checks.....	37
Chapter 6	Installation procedure.....	39
	6.1 External components assembly.....	39
Chapter 7	Testing the product.....	41
	7.1 Commission the control valve.....	41
Part III	Operate	
Chapter 8	Operation parameters.....	45
	8.1 Control valve normal operation.....	45
	8.2 Operation accessories.....	45
	8.3 Operation overview.....	45

Part IV Maintain

Chapter 9	Planned maintenance.....	49
	9.1 Maintenance considerations.....	49
	9.2 Tools required for mechanical components.....	49
	9.3 Disassemble/Assemble the control valve.....	49
	9.4 Mechanical assembly.....	53
	9.5 Planned maintenance tasks.....	62
Chapter 10	Corrective maintenance.....	63
	10.1 Control valve troubleshooting.....	63
	10.2 Verify the return to operational condition.....	64
Chapter 11	Spare parts.....	65
	11.1 Order spare parts.....	65
Chapter 12	Decommission.....	67
	12.1 Shut down the control valve.....	67
	12.2 Shipment of the control valve.....	67

Part I

Plan

1 Introduction

1.1 Purpose of this manual

This manual provides guidance to owners and personnel in the installation, operation and maintenance of the *Daniel™ Model 700 Control Valve manual, 3-9008-553*. It is imperative that product owners and operation personnel read and follow the information contained in this manual to ensure that the control valve is installed correctly and is operating according to the design certifications and safety considerations.

1.2 Hazard messages

This document uses the following criteria for hazard messages based on ANSI standards Z535.6-2011 (R2017).



Serious injury or death will occur if a hazardous situation is not avoided.



Serious injury or death could occur if a hazardous situation is not avoided.



Minor or moderate injury will or could occur if a hazardous situation is not avoided.

NOTICE

Data loss, property damage, hardware damage, or software damage can occur if a situation is not avoided. There is no credible risk of physical injury.

Physical access

NOTICE

Unauthorized personnel can potentially cause significant damage and/or misconfiguration of end users' equipment. Protect against all intentional or unintentional unauthorized use. Physical security is an important part of any security program and fundamental to protecting your system. Restrict physical access to protect users' assets. This is true for all systems used within the facility.

1.3 Personnel qualifications

Read and follow all instructions, dangers, warnings, and cautions to avoid personal injury or property damage during system operation. Emerson is not responsible for damage or injury resulting from unsafe use of products, lack of maintenance, incorrect installation of equipment or system operation. If in doubt about any applications and safety precautions described in this document, contact Emerson.

Inform and train all personnel in the proper installation, operation, and maintenance of this product. To ensure safe and proper performance, only informed and trained personnel should install, operate, repair and maintain this product. For further questions about training requirements, contact your local Emerson representative.

Operations risk assessment must be used and followed in conjunction with this document when performing all online retrieval operations.

Ensure that all end user and installation specific safety requirements are read, understood and adhered to.

Ensure that any operator that is conducting work on the equipment, is following end user guidelines on the use of protective equipment including, but not limited to:

- Safety helmet or hard hat
- Steel-toed shoes
- Safety glasses
- Working gloves (suitable for mechanical operations)
- Chemical resistant latex gloves or the equivalent
- Long-sleeved, fire-retardant shirt and fire-retardant trousers or full-length fire retardant coveralls

Additional PPE may be required depending on facility requirements and MSDS requirements, if applicable. Failure to comply may result in personnel injury.



WARNING

RISK TO PERSONNEL AND EQUIPMENT

Failure to follow the installation, operation or maintenance instructions for a Daniel product could lead to serious injury or death from explosion or exposure to dangerous substances. To reduce the risk:

- Comply with all information on the product, in this manual, and in any local and national codes that apply to this product.
- Do not allow untrained personnel to work with this product.
- Use Daniel parts and work procedures specified in this manual.

NOTICE

Observe all precautionary signs posted on the equipment to avoid serious injury.



WARNING

RISK TO PERSONNEL AND EQUIPMENT

Operation of this product on pressurized lines may potentially imply operational risk for personnel and equipment from the potential escape of hot gas or liquid, which could result in serious injury.

Observe all precautionary signs on the equipment.

 **WARNING**

RISK TO PERSONNEL AND EQUIPMENT

The operation of the Daniel product involves heavy equipment handling. Observe the following guidelines to avoid potentially serious injury:

- Be aware of your limitations and ask for assistance if needed.
- Do not attempt to lift weight beyond your capacity.
- Lift with your legs, not your back.

Note

Mechanical lifting tools may also be used in some locations to reduce risk.

NOTICE

Attending the training course for this product is not considered sufficient for operating the tool on pressurized lines. Emerson requires a two-man crew with formal training.

Additionally, at least one of the operators must have a record of extensive field experience and be certified for this work.

Emerson assumes no responsibility for incidents, or consequences of incidents, occurring as a result of the use of this product by others than Emerson or its designated personnel, and have no liability whatsoever for any such work.

Consult Emerson for more details on both training and certification.

1.4 Warranty restrictions

Visually inspect all components for shipping damage. If shipping damage is found, notify the carrier at once. Shipping damage is not covered by the warranty. The carrier is responsible for all repair and replacement costs resulting from shipment damage.

1.5 Assistance

The Emerson Global Service Center is organized through a network of service centers worldwide, and supports all service requirements or technical queries. For the Product Support Help Desk, go to: <http://www.emerson.com> or contact your nearest Emerson service provider.

1.6 Description of the Model 700 Control Valves

1.6.1 General features of the control valve

The Daniel™ Model 700 Control Valve operates on a balanced piston principle, spring biased (loaded) to the closed position.

The valve can be configured as a check valve to prevent reverse flow. It is possible, in some applications, to reverse flow through the pilot control loop, but this can be eliminated by installing a check valve in the X-port.

The Daniel Model 700 Control Valves have the following characteristics:

- Modular construction: All internal parts including seat ring can be removed with the cylinder assembly without disturbing line connections.
- No diaphragms or stuffing boxes
- 45° body design assures high capacity
- Positive shut-off
- Uniform speed-of-response
- Linear control
- O-ring plus metal-to-metal seat
- Pilots and other optional accessories enable the valve to perform a variety of control functions such as back pressure control, regulating rate-of-flow, pressure relief, surge control, etc.

1.6.2 Control valve applications

This is the starting point for unlimited control applications. The basic valve needs to incorporate a pilot control loop, which is mandatory for it to function, see *Daniel Liquid Control Valves Technical Guide (P/N DAN-LIQ-TG-44)* for specific applications.

1.6.3 Operation overview of the control valve

The basic valve operates on a balanced piston principle, spring biased (loaded). Refer to [Figure 1-1](#). The term balanced piston means that the exposed area on the spring side (P3) of the piston and the bottom side (P1) are equal in area. The spring is the differential force that closes the piston when (P1) and (P3) pressures are equal.

To open the valve, the pressure against the bottom of the piston (P1) must exceed the pressure on the spring side of the piston (P3) plus spring force.

Closed position

[Figure 1-1](#) illustrates the closed valve. Y-port (P3) to Z-port (P2) is closed. X-port (P1) and Y-port (P3) pressures are balanced. The differential force created by the main valve spring, closes the piston and keeps it seated.

Therefore, total pressure equals 40 psi @ (P1) and 45 psi @ (P3) or (P3 minus P1) - 5 psid. The needle valve/strainer controls the speed of the closure by controlling the flow through the X-port.

Figure 1-1: Pilot in closed position

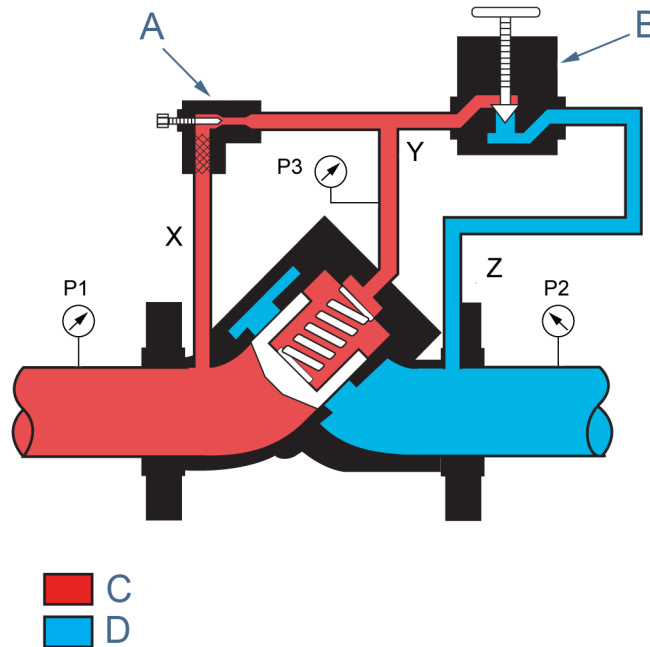

- A. Needle valve / strainer
- B. Manual pilot control
- C. Inlet pressure
- D. Outlet pressure

Fully open - No control

In [Figure 1-2](#) the valve is fully open. Y-port (P3) is open to Z-port (P2). The pressure on the bottom of the piston (P1) is greater than the pressure at (P3) plus spring force. The valve will not open unless the pressure drop across the valve (P1 minus P2) is slightly greater than the force applied by the main valve spring. In a non-control state, the main valve is opened in a percentage directly proportional to (P1 minus P2).

Figure 1-2: Pilot in fully open position

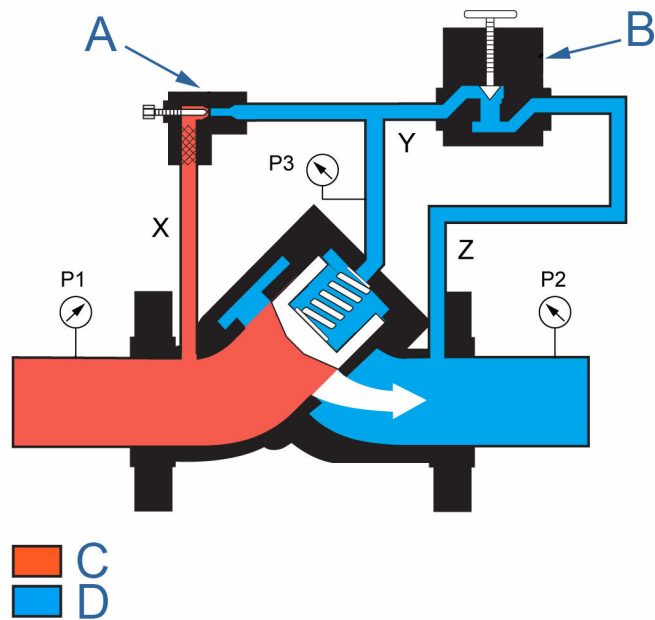

- A. Needle valve / strainer
- B. Manual pilot control
- C. Inlet pressure
- D. Outlet pressure

Open controlled position

In [Figure 1-3](#) the valve is partially open. Y-port (P3) is open to Z-port (P2) but is being restricted by the control pilot. The pilot control is a variable orifice that regulates the pressure at Y-port (P3) by controlling the flow through Z-port. Increasing or decreasing the Y-port pressure (P3) causes the piston to change positions.

Figure 1-3: Pilot in partially open position

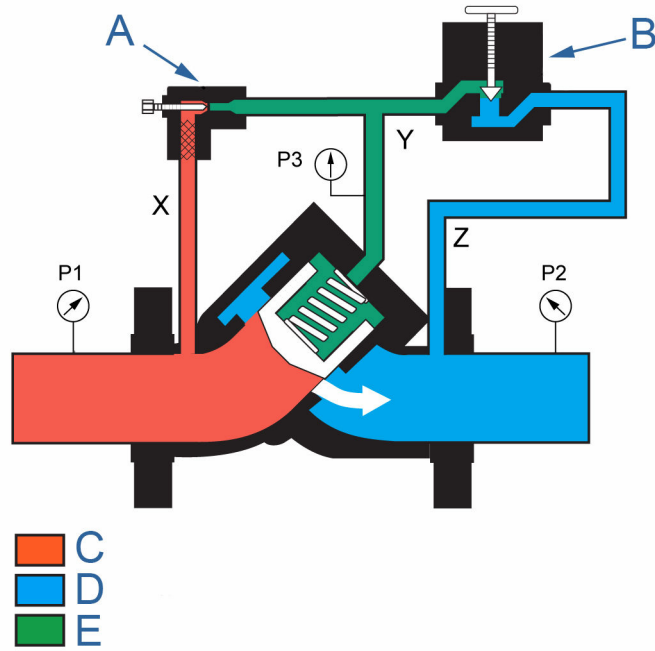

- A. Needle valve / strainer
- B. Manual pilot control
- C. Inlet pressure
- D. Outlet pressure
- E. Controlled pressure

1.6.4 Parts list for the Series 700 Control Valves

Figure 1-4: Part identification for an NPS 2-12 inch Control Valve

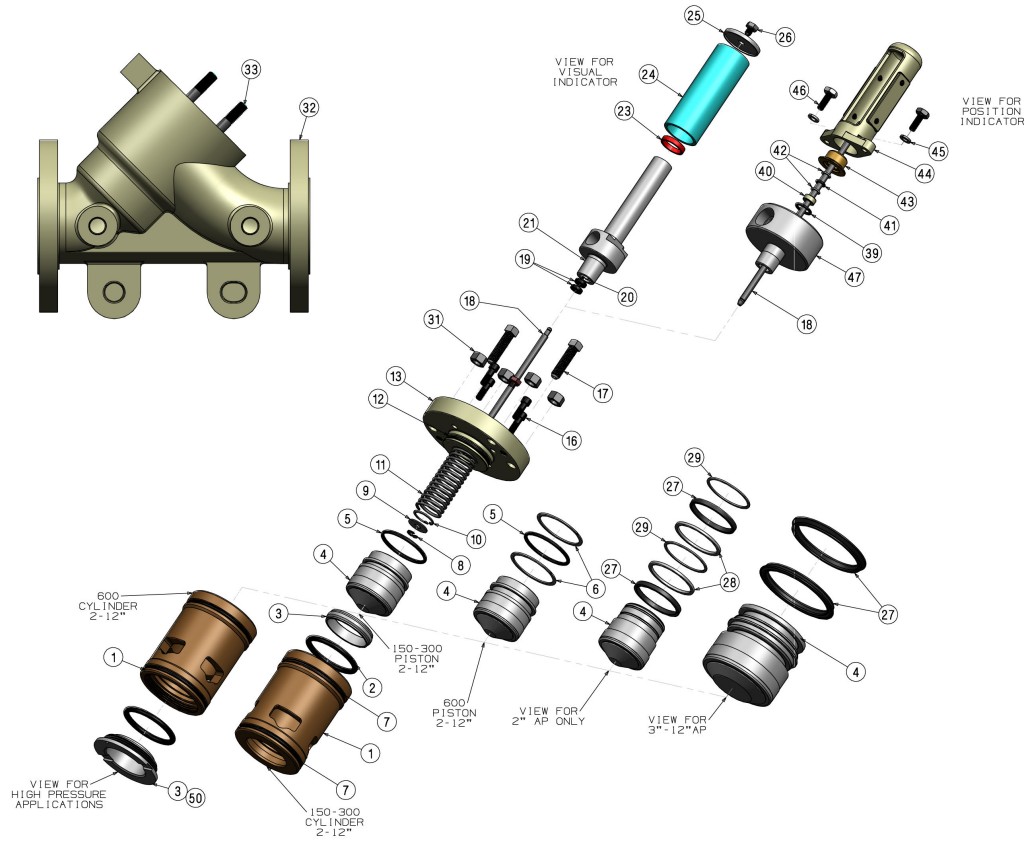

NOTICE

Item numbers are not meant to be consecutively numbered.

Table 1-1: Part description for Model 700 Control Valve NPS 2 - 12

Item number	Description	Quantity
1	Cylinder	1
2	O-ring	1
3	Seat ring	1
4	Piston	1
5	O-ring	1
6	Backup ring	2
7	O-ring	2
8	Retaining ring	1
9	Washer	1

Table 1-1: Part description for Model 700 Control Valve NPS 2 - 12 (continued)

Item number	Description	Quantity
10	Retaining ring	1
11	Spring	1
12	O-ring	1
13	Cylinder head	1
16	Screw	4
17	Jack-out screws	2
18	Indicator stem visual	1
	Indicator stem micro-switch	
19	Magnet	2
20	Retaining ring	1
21	Indicator adapter	1
22	Cap plug	1
23	Ring magnet	1
24	Indicator housing	1
25	Indicator top	1
26	Screw	1
27	Bal-seal	2
28	Piston seal retainer	2
29	External retaining ring	2
31	Nuts	8
32	Valve body	1
33	Studs	8
34	Pipe plug	2
38	Cap plug	1
39	O-ring	1
40	Seal retainer	1
41	O-ring	1
42	Backup ring	2
43	Upper bearing	1
44	Indicator guard	1
45	Lock washer	2
46	Screws	2
47	Indicator adapter	1

Table 1-1: Part description for Model 700 Control Valve NPS 2 - 12 (continued)

Item number	Description	Quantity
48	Cap plug	1
50	Set Screw	1
A	Cylinder assembly class 150 and 300	
	Cylinder assembly class 600	

Figure 1-5: Part identification for an NPS 16 inch Control Valve

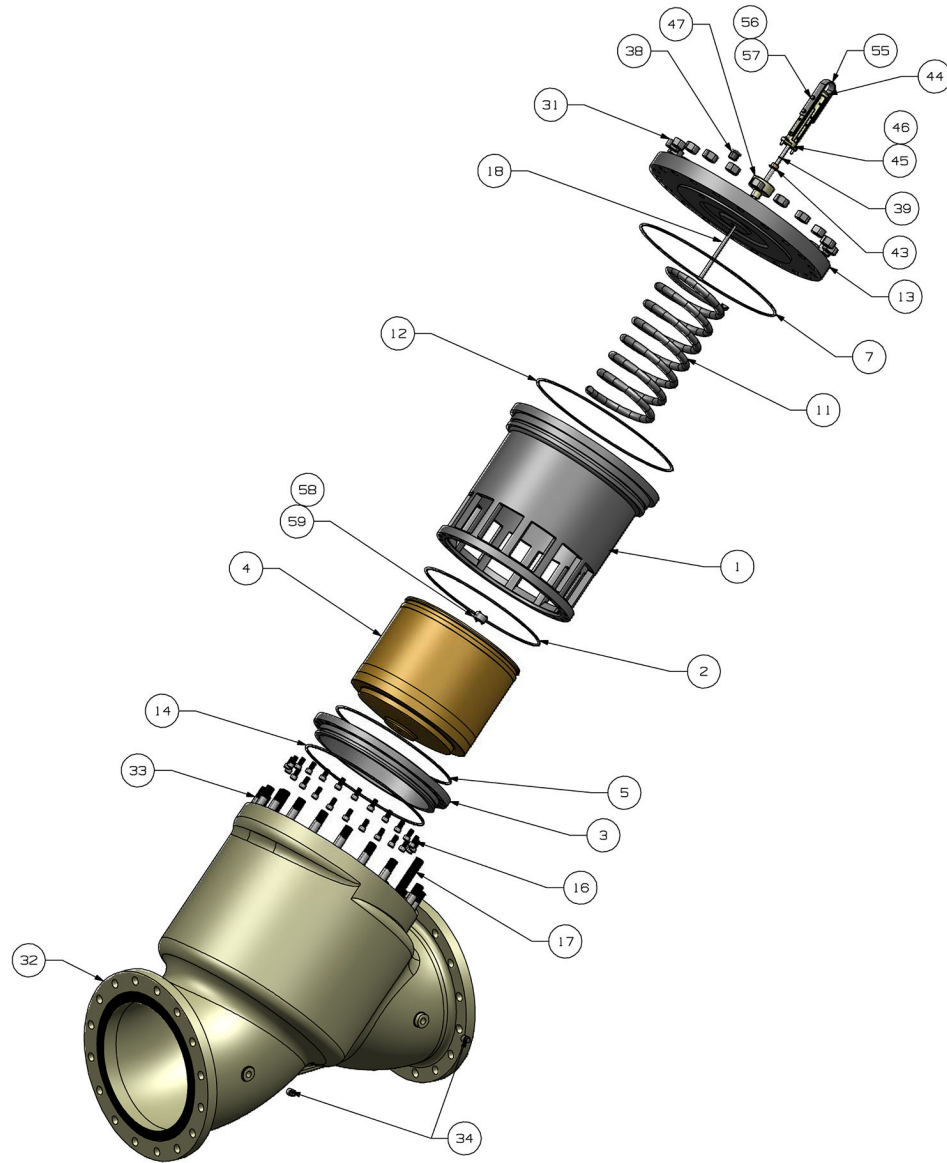

Table 1-2: Part description for Model 700 Control Valve NPS 16

Item number	Description	Quantity
1	Cylinder	1
2	O-ring	1
3	Seat ring	1
4	Piston	1
5	O-ring	1

Table 1-2: Part description for Model 700 Control Valve NPS 16 (continued)

Item number	Description	Quantity
6	Backup ring	2
7	O-ring	2
11	Spring	2
12	O-ring	1
13	Cylinder head	1
14	O-ring	8
16	Screw	24
17	Jack-out screws	2
18	Indicator stem micro-switch	1
31	Nuts	8
32	Valve body	1
33	Studs	40
34	Pipe plug	2
38	Cap plug	1
39	O-ring	8
43	Upper bearing	1
44	Indicator guard	1
45	Screw	2
46	Washer	2
47	Indicator adapter	1
55	Indicator Ext. guard	1
56	Screw	4
57	Washer	4
58	Piston plug	1
59	Screw	3

1.7 Agency certifications for control valves Model 700

The following product agency certifications are applicable to the Daniel control valves.

Table 1-3: Agency certifications for control valves

Certification type	Description
Pressure equipment	PED

2 Operating conditions and specifications

2.1 Operating conditions for the control valve

Table 2-1: Operating conditions for the control valve

Condition type	Description
Fluid phase	Liquid
Process temperature	-20° F to 150° F (-29° C to 66° C)
Optional process temperature	-50° F to 400° F (-46° C to 205° C)
Fluid velocity	Operational recommended flow velocity up to 30 ft/sec, beyond this point will result in a high pressure drop and increased wear.
Fluid(s) controlled	<ul style="list-style-type: none"> • Low/Medium viscosity crude oils and condensates • Refined products and intermediates (ie: <i>gasoline, diesel, kerosene, light fuel oils, jet fuel, LPG, butanes, naphtha, alkylate, reformate, straight run gasoline, cat-cracked gasoline</i>) • Petrochemicals (ie: <i>benzene, toluene, xylenes, cumene, olefins, pyrolysis gasoline</i>) • Natural gas liquids
Viscosity limits on valves and valves with pilots	<ul style="list-style-type: none"> • Maximum valve viscosity is 8800 Cst • Maximum viscosity for valves with pilots is 440 Cst due to response time of high viscosity pilot
Differential pressure	The maximum allowable differential pressure across a control valve is 6894 kPa (1,000 psi). Consult factory for location of first shut down valve.
Atmospheric pressure	Absolute
Sizes (NPS)	2, 3, 4, 6, 8,10,12,16
Pressure class (ANSI)	150, 300, 600
Maximum safe working temperature range	<ul style="list-style-type: none"> • 15° F to 400° F (-26° C to 204° C) • Using FKM O-rings • Temperature range is dependent of O-ring T_{min} and T_{max} • Max temperature of valves with solenoid pilots is standard -20° F to 150° F (-29° C to 66° C) (if applicable), Optional 250° F (121° C) • Consult the factory for other safe working temperatures

Table 2-1: Operating conditions for the control valve (continued)

Condition type	Description
Maximum safe working pressure	<p>Flange connections/Ratings (DIN) for valve sizes DN50 and DN400:</p> <ul style="list-style-type: none"> • DIN PN16 MWP at 120° C: 16 bar • DIN PN25 MWP at 120° C: 25 bar • DIN PN40 MWP at 120° C: 40 bar • DIN PN64 (class 300) MWP at 120° C: 51 bar • DIN PN64 (class 600) MWP at 120° C: 64 bar • DIN PN100 MWP at 120° C: 100 bar <p>Flange connections/Ratings (ANSI) for valve sizes 2-in to 16-in:</p> <ul style="list-style-type: none"> • Class 150 MWP at 100° F: 285 psi • Class 300 MWP at 100° F: 740 psi • Class 600 MWP at 100° F: 1480 psi <p>* MWP: Maximum Working Pressure</p>
Materials of construction	<p>Main valve body: Steel, ASTM-A352 Gr. LCC</p> <p>Main valve cylinder:</p> <ul style="list-style-type: none"> • NPS 2-4: Stainless steel • NPS 6 and larger: Nickel coated steel <p>Main valve piston: Stainless steel (standard)</p> <p>Seat ring:</p> <ul style="list-style-type: none"> • Class 150 and 300: <ul style="list-style-type: none"> — NPS 2-6: Stainless steel — NPS 8-16: Nickel coated steel • Class 600: Stainless steel <p>O-Rings:</p> <ul style="list-style-type: none"> • Standard: FKM • Optional: CR, EPR, FKM V1289, NBR, FFKM, FKM GLT • For other material contact the factory <p>External hook up:</p> <ul style="list-style-type: none"> • Class 150 and 300: <ul style="list-style-type: none"> — NPS 2-6: Carbon steel/Stainless steel 10 mm (0.375-in) — NPS 8-16 Carbon steel/Stainless steel 13 mm (0.5-in) • Class 600: <ul style="list-style-type: none"> — NPS 2-6: Stainless steel 13 mm (0.5-in) — Can be furnished in metric sizes <p>Other internal parts: Stainless steel</p>

Table 2-1: Operating conditions for the control valve (continued)

Condition type	Description
Valve capacity	<p>C_v is a capacity coefficient that defines as the number of US gpm of water that flows through a valve with a pressure drop of 1 psi across the valve. Daniel valves have the following C_v:</p> <ul style="list-style-type: none"> • NPS 2: 86 gpm • NPS 3: 186 gpm • NPS 4: 309 gpm • NPS 6: 688 gpm • NPS 8: 1296 gpm • NPS 10: 2040 gpm • NPS 12: 2920 gpm • NPS 16: 5360 gpm <p>*C_v based on wide open valve with water temperature at 60° F (16° C)</p>

2.1.1 Design considerations

Some conditions to consider:

- Service operating pressure
- Service testing pressures
- Service process temperature and ambient site temperatures
- Chemical composition and toxicity of fluid in operating conditions
- Traffic, wind and earthquake at loading site
- Adverse force or stress caused by inadequate supports, attachments, piping, etc.
- Corrosion, erosion, fatigue, etc.
- Decomposition of unstable fluids in operating and test conditions
- Possible damage from external fire
- Mass fluid in process and test conditions

WARNING

FUNCTIONAL AND ENVIRONMENTAL HAZARD

Evaluate the functional and environmental conditions prior to installing a control valve. Install the control valve in a well-designed piping system.

Failure to comply may result in death or serious injury from pipe failure.

2.1.2 Environmental conditions



WARNING

EQUIPMENT HAZARD

Never use this equipment for any purpose other than its intended use.

Failure to comply may result in death, serious personal injury and/or property damage.

Table 2-2: Environmental conditions

Parameter type	Description
Severe service conditions	Ensure that piping or other attachments connected to the valve are not under stress. The design of the control valve has not been assessed for the effects of wind, earthquake loading and severe weather conditions.
Additional severe service conditions	The valves are designed to be used on liquid applications for crude oil and refined products. The use of aggressive additives or oxygenates requires the use of the Aggressive Products (AP) option. The AP option valve cylinder incorporates cup-seals (PTFE Bal Seals) and an O-ring made from appropriate materials for severe conditions.
Corrosive service	Select the material compatible with the specific processes and atmospheric environments. Implement a periodic inspection and maintenance program to ensure that pressure retaining components are free from corrosion and erosion. The valve is not designed with corrosion allowance. Inspect the valve's metal parts periodically for corrosion and erosion, and inspect the seals and O-rings for wear and chemical deterioration.
Low and freezing temperatures	Low specific gravities or high viscosities reduce the flow range of the valve. Refer to Operating conditions for the control valve for more information.
Populated areas	For new installations, locate the control valve to an area that has fewer than 10 buildings intended for human occupancy within an area that extends 200 meters (220 yards) radially from the control valve. (Reference: Class 1 Location: U.S. DOT, CFR Title 49: Part 192.5)
Closed, poorly ventilated areas	Install the control valve in a well ventilated area, not less than one meter (approximately three feet) from source of ignition or source of heat which might damage the unit.
Elevation	No limit
Humidity	No limit
Proximity to open flame	Provide fire prevention measures and equipment per local regulations.
Proximity to vehicular traffic	The design of the control valve has not been assessed for the effects of traffic.

2.2 Specifications for the control valve

2.2.1 Interface requirements

 **WARNING**

EXCEEDING REQUIREMENTS HAZARD

Control valve requirements are defined to ensure safe equipment operation. Do not exceed published specifications.

Failure to comply may result in death, serious injury and/or damage to the equipment.

Table 2-3: Interface requirements

Requirements	Description
Hydraulic lines	External hook up: <ul style="list-style-type: none"> • ANSI class 150 and 300: <ul style="list-style-type: none"> – NPS 2-6: Carbon steel/Stainless steel 10 mm (0.375-in) – NPS 8-16 Carbon steel/Stainless steel 13 mm (0.5-in) – Can be furnished in metric sizes • ANSI class 600: <ul style="list-style-type: none"> – NPS 2-16: Stainless steel 13 mm (0.5-in) – Can be furnished in metric sizes
Flange type	The mechanical connections for a Series 700 control valve NPS 2 to 16 are standard class 150, 300 and 600 ANSI R.F. flanges, which are available only in carbon steel. Other types of flange connections are available per customer request for Daniel control valves. For other ANSI ratings or flanges consult the factory engineers. For maximum working pressures at intermediate temperatures refer to ANSI B16.5.

 **WARNING**

FLANGE SIZE HAZARD

Customers must choose the appropriate size material of the flange for their piping requirements.

Choosing an incorrect flange may cause a pressure leak, resulting in death or serious injury.

2.2.2 Requirements and limitations for installation

NOTICE

Comply with local government regulations and company requirements.

See [Figure 2-1](#) for flow direction.

NOTICE

Flush lines to remove welding bead, pipe scale, etc.

NOTICE

Install the valve in a horizontal line with the cylinder head at the top.

Figure 2-1: Valve orientation

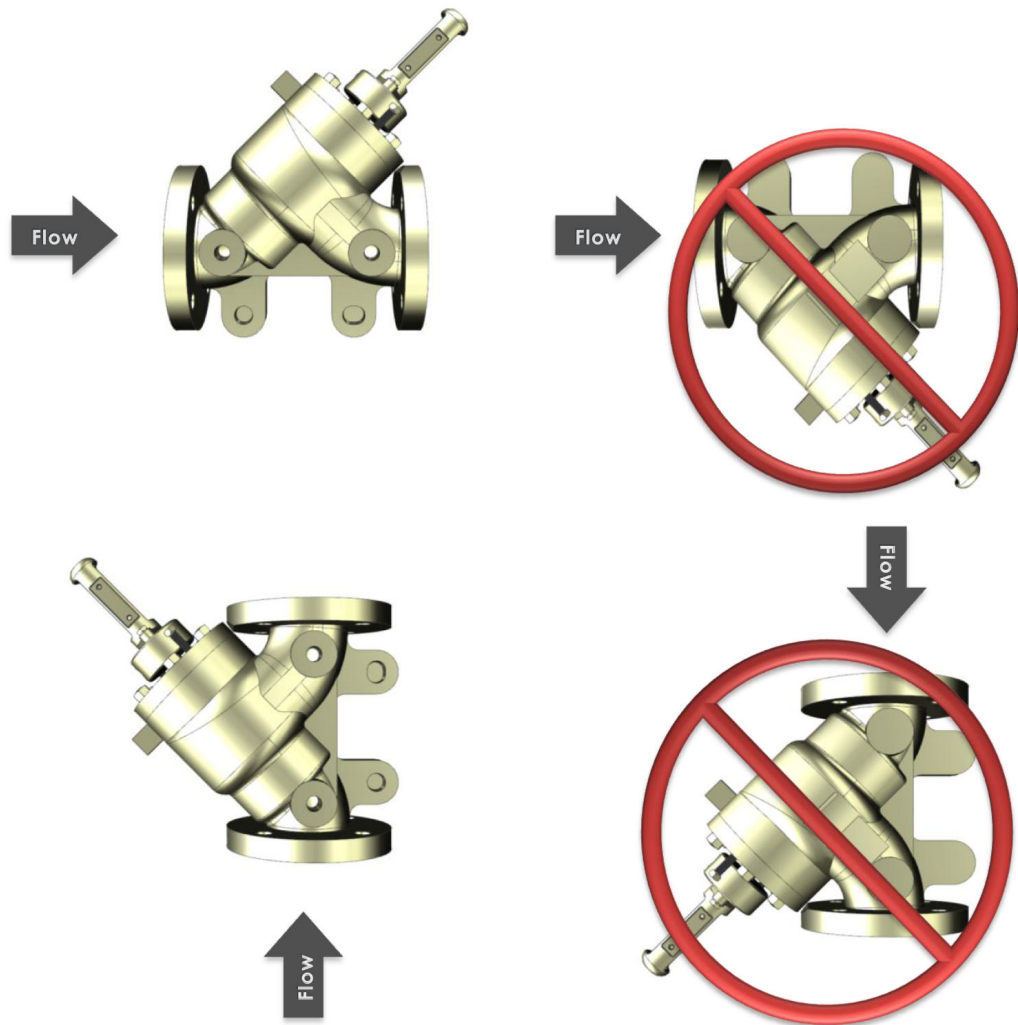

! WARNING

EQUIPMENT HAZARD

Never use this equipment for any purpose other than its intended use.

Failure to comply may result in death, serious personal injury and/or property damage.

2.2.3 Minimum clearances for installation, operation and maintenance

For certified prints, consult the factory.

Figure 2-2: Dimensions of the control valve

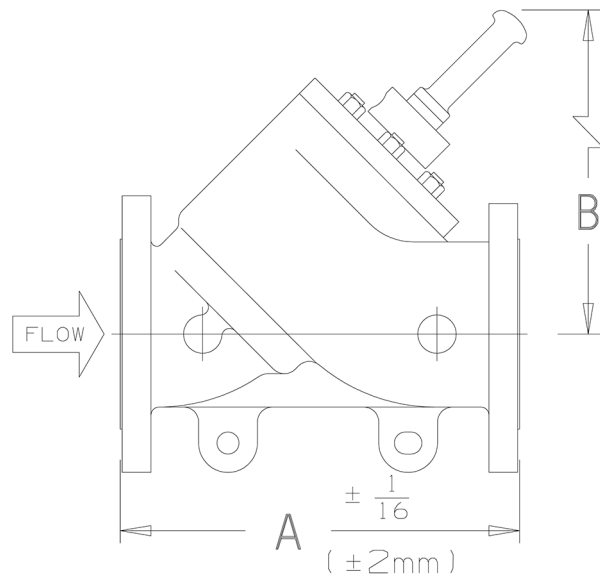

Table 2-4: Weight and volume table for the control valve (Approximate)

Size (inches)	150 lb. (ANSI)		300 lb. (ANSI)		600 lb. (ANSI)		150-300 lb. (ANSI)		600 lb. (ANSI)	
	lbs.	Kg.	lbs.	Kg.	lbs.	Kg.	Cubic feet	Cubic meters	Cubic feet	Cubic meters
2	55	25	60	27	100	45	1.66	0.047	1.79	0.051
3	95	43	105	48	150	68	2.36	0.067	2.5	0.071
4	115	52	140	64	205	93	2.51	0.071	3.13	0.089
6	210	95	250	113	400	181	4.84	0.137	6.07	0.172
8	400	181	465	211	725	329	8.94	0.253	9.96	0.283
10	640	290	700	318	1170	531	12.08	0.342	15.13	0.428
12	1040	472	1251	567	1820	826	20.25	0.573	21.94	0.621
16	CF	CF	CF	CF	CF	CF	39.53	1.119	42.17	1.194

CF = consult factory

Table 2-5: Dimensions for the control valve

Valve Size	A						B			
	Class 150		Class 300		Class 600		Class 150-300		Class 600	
	inches	mm	inches	mm	inches	mm	inches	mm	inches	mm
2	10-1/4	260	10-1/2	267	11-1/2	292	9-5/8	244	9-3/4	248
3	11	279	13-1/8	333	14	356	10-3/8	264	11-1/4	286
4	13	330	14-1/2	368	17	432	10-7/8	276	11-1/2	292
6	17	432	17-7/8	454	22	559	13-3/8	340	13-5/8	346
8	22-1/4	565	23-1/4	590	26	660	17-1/4	438	17-3/4	451
10	26-1/2	673	27-7/8	708	31	787	17-5/8	448	20-5/8	524
12	30-7/8	784	33-5/8	854	36-1/2	927	20-7/8	530	22-7/8	581
16	41-3/8	1051	43-1/2	1105	46	1168	30	762	30	762

3 Control valve handling

3.1 Receive the control valve

 **WARNING**

EQUIPMENT HANDLING AND OPERATING HAZARD

Wear personal protective equipment appropriate to the situation when working with the control valve. Adhere to all safety standards and best practices for operating the equipment.

Failure to comply may result in death or serious injury.

3.1.1 Unpack and inspect the control valve

Check the control valve when it is received at the customer facility.

Procedure

1. Remove the control valve from the shipping container.
2. Inspect the control valve for damage.
3. See [Installation procedure](#).

3.2 Store the control valve

3.2.1 Rust inhibitor

Apply light oil or rust inhibitor on surfaces that are in contact with the environment.

3.2.2 Pack the control valve

Procedure

1. Use stretch wrap (not adhesive) to attach the correct size flange cover to the valve end flanges. This protects the unpainted surfaces of the flange sealing.
2. A flush contact between the flange cover and the flange sealing face is important.

3.2.3 Storage conditions

Store the control valve in a safe area to avoid damage.

 **WARNING**

CRUSHING HAZARD

During installation or removal of a control valve, always place the unit on a stable platform or surface that supports its assembled weight.

Failure to comply may allow the control valve to roll, resulting in death, serious injury or equipment damage.

Table 3-1: Control valve storage conditions

Parameter type	Description
Storage environment conditions	For long term storage, it is recommended that the complete control valve assembly be stored under cover in a controlled environmental atmosphere in the original packaging. The storage temperature limits are: 68° F to 140° F (20° C to 60° C).
Shelf life for elastomers	Inspect O-rings for wear or damage during disassembly of the cover and right before assembling the unit. Replace damaged elastomer. Viton [®] has an unlimited shelf life.
Inspect stored equipment	Examine the internal surfaces and flange faces of the control valve at least once every three months. Repack the control valve as originally received.
Labels and nameplates	Do not remove nameplates or labels. Doing so will void the control valve warranty.
Stacking conditions	When stacking equipment, follow all the safety standards taking into account the type of box used, the maximum height of the equipment, the maximum number of boxes stacked, etc.

4 Prepare the control valve for use

4.1 Lifting conditions

 **WARNING**

CRUSHING HAZARD

During installation or removal of a control valve, always place the unit on a stable platform or surface that supports its assembled weight.

Failure to comply may allow the control valve to roll, resulting in death, serious injury or equipment damage.

 **WARNING**

LIFTING HAZARD

The lifting instructions are for installation and removal of a Daniel control valve only and do not address lifting the control valve while it is attached or bolted to piping.

Failure to follow these instructions may result in death, serious injury or equipment damage.

 **CAUTION**

FORKLIFT HAZARD

Do not insert the forks of a forklift into the bore when moving the control valve.

Inserting the forks may cause the meter to become unstable, resulting in serious injury or equipment damage.

Table 4-1: Lifting and installation conditions

Conditions	Description
Ventilation and lightning	Install the control valve in a well lit and ventilated location, not less than one meter (approximately three feet) from source of ignition or source of heat which might damage the unit.
Work area clearances and installation height restrictions	Refer to Minimum clearances for installation, operation and maintenance for clearances.
Surface considerations	Stable surface.
Soil/floor loadings and product/piping support	Follow local procedures that meet the standards for soil/floor loading and product/piping support.

4.2 Lifting requirements for personnel

4.2.1 Safety precautions using appropriately rated lifting slings



WARNING

LIFTING HAZARD

The lifting instructions are for installation and removal of a Daniel control valve only and do not address lifting the control valve while it is attached or bolted to piping.

Failure to follow these instructions may result in death, serious injury or equipment damage.

- Only personnel properly trained in the safe practices of rigging and lifting should lift valves.
- Prior to use, visually inspect the slings for any signs of abrasion or other damage. Refer to the sling manufacturer for inspection procedures specific to the sling you are using.
- Never attempt to lift the valve by wrapping slings around the visual indicator, position indicator pilots, needle valves, accessories or tubing.
- Never attempt to lift the valve using only one sling around the valve. Always use two slings wrapped around each end of the body as shown below. Use a choker style sling with a spreader bar.

Figure 4-1: Correct sling attachment

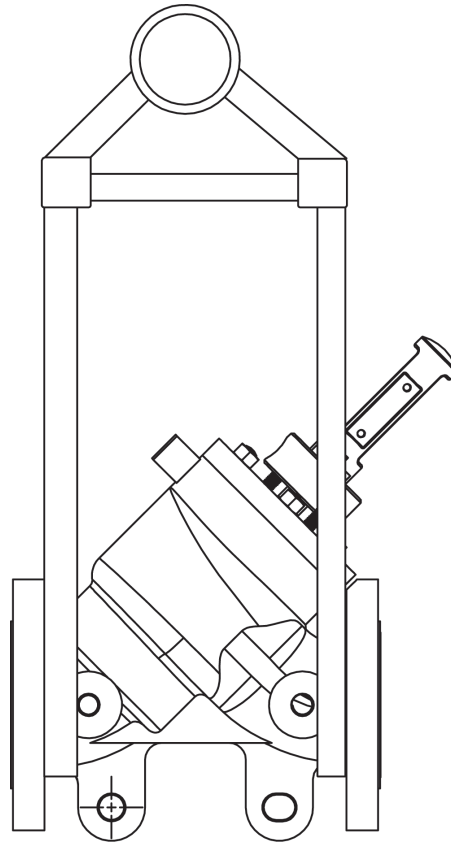

- Only use slings with ratings that exceed the weight to be lifted. Reference all safety standards for safety factors that must be included when calculating the load rating.

⚠ CAUTION

SLING HAZARD

Never allow the slings to come in contact with the visual indicator, position indicator, pilots, needle valves, accessories or tubing. Use a spreader bar on the sling to prevent contact.

Failure to comply may cause equipment damage.

- Never apply shock loads to the valve. Always lift the control valve gradually. If shock loading occurs, inspect the slings per manufacturer's procedures before reuse.

⚠ WARNING

EQUIPMENT HANDLING AND OPERATING HAZARD

Wear personal protective equipment appropriate to the situation when working with the control valve. Adhere to all safety standards and best practices for operating the equipment.

Failure to comply may result in death or serious injury.

4.3 Configure the control valve

The factory configures Daniel control valve internal components. Inspect the internal components before installation.

4.3.1 Orientation and position of the control valve

Flow direction

NOTICE

Comply with local government regulations and company requirements.

NOTICE

Flush lines to remove welding bead, pipe scale, etc.

NOTICE

Install the valve in a horizontal line with the cylinder head at the top.

Figure 4-2: Control valve flow direction

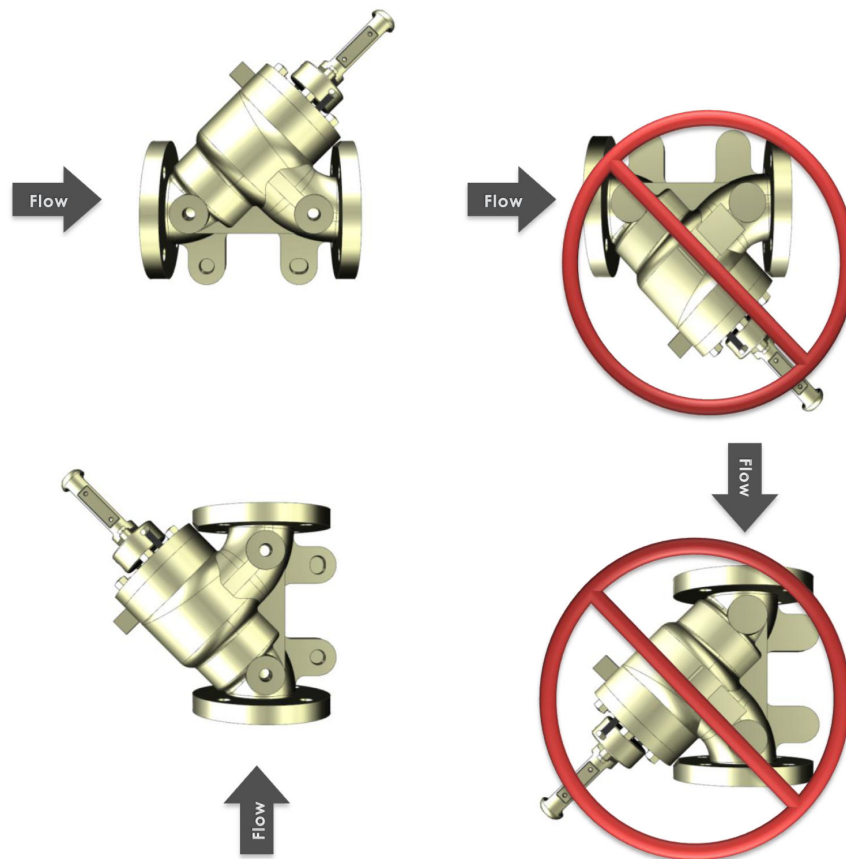



WARNING

EQUIPMENT HAZARD

Never use this equipment for any purpose other than its intended use.

Failure to comply may result in death, serious personal injury and/or property damage.

4.3.2 Piping recommendations

The design of the control valve has not been assessed for the effects of traffic, wind or earthquake loading.

Important

Ensure that piping or other attachments connected to the control valve are not under stress.

Important

Provide fire prevention measures and equipment per local regulations.

Part II

Install

5 Installation prerequisites

5.1 Pre-start checks

Ensure that the pipeline is completely free of all foreign material before installing the valve.

6 Installation procedure

6.1 External components assembly

The control valve is assembled at the factory. The components do not need to be uninstalled or reinstalled unless maintenance is required.



CAUTION

SURFACE TEMPERATURE HAZARD

The control valve body and piping may be extremely hot or cold.

Wear personal protective equipment appropriate to the situation when working with the control valve. Adhere to your company's safety standards and practices.

Failure to comply may cause serious injury.

7 Testing the product

7.1 Commission the control valve

After installation, commission the control valve to ensure that the equipment is working properly.

Procedure

1. Inspect all bolts used to secure the control valve in-line to ensure that proper mounting procedures have been followed and that flange connections are leak-free.
2. Evaluate the system setup to ensure that all components are in the correct operating sequence.
3. Evaluate the system setup to ensure that all components are in the correct sequence for accurate product measurement. Some components are isolation valves, strainers, flow straighteners, turbine meters, downstream sections, etc.

Part III

Operate

8 Operation parameters

8.1 Control valve normal operation

Models 700 Control Valve is versatile valve in the market. It can incorporate any single or multiple control function(s) to meet the exact requirements for on - off in modulating control of liquid products. Control combinations are virtually unlimited.

All series 700 control valves are pressure balanced, single-seated piston operated with 45° body construction. The valves are hydraulically operated and use the flowing stream as the power medium. All are equipped with a needle valve in the pilot supply line for adjusting the closing rate and for sensitivity control. A strainer is also incorporated in the pilot flow line, upstream of the needle valve.

Unique design features and unit-built construction ensures positive leak-proof performance. In addition, the basic valves body and internals are the same throughout the line, simplifying spare parts inventory and reducing costs.

8.2 Operation accessories

- Opening speed control: Device installed in the Y port of the valve to control opening speed
- Thermal relief: It is the pressure differential safety device use to eliminate excessive pressures caused by thermal expansion.
- Block or isolation valve for X, Y, Z ports
- Manual override: Device used to by-pass the pilot module
- Valve position indicator
- Limit switches: The sequential switches convert the mechanical motion of the batch controlling mechanism of the preset counter to electrical signals used to control the solenoid pilots of the control valve for low flow position-shut down and/or start-up.
- Orifice flanges

It is recommended to ensure that both the line and the product are clean before the valve is installed. Small particles of foreign material usually will not effect the performance of the valve, although larger particles may damage the valve piston and its seat.

8.3 Operation overview

Operation of the Model 700 Control Valve is based on a balanced piston principle.

When pressure on both sides of the main valve piston are equal, a spring (located on the top of the piston) acts as a differential force and closed the main valve piston. As pressure against the bottom of the piston increases and exceeds the pressure exerted against the top of the piston, plus the force of the spring, spring tension is overcome and the valve opens.



CAUTION

EQUIPMENT DAMAGE

Read the entire recommended procedure for all installation operations and maintenance procedures before attempting to install or disassemble the valve. Disassembly of this cylinder assembly is different from previous Daniel control valves and requires strict adherence to the procedures outlined in this manual.

Failure to read and comply with these procedures could result in damage to the equipment and compromise in the integrity of the operation.

Part IV

Maintain

9 Planned maintenance

9.1 Maintenance considerations

Read and understand all instructions and operating procedures before performing maintenance procedure, internal component inspection, or field requirement changes.

To ensure safe and accurate performance, only informed and trained personnel should install, operate, repair and maintain this product.

Follow the recommendations below before servicing the control valve:

1. Label all parts or place parts in labeled containers during disassembly.
2. Do not use metal clamping devices in direct contact with any control valve part or surface.

Important

All control valve adjustments were completed at the factory during liquid calibration and should not require field setup.

9.2 Tools required for mechanical components

Flange installation tools

Follow all best practice procedures when installing or removing flanges.

Control valve components

The control valve does not have pre-installation requirements. If installation is required for maintenance purposes, use the following tools:

- Socket wrench
- Adjustable wrench
- T-handle or extended Allen wrench
- Arbor press (may be needed for 4- and 6-inch valves)
- Retaining ring pliers

9.3 Disassemble/Assemble the control valve

Before removing the control valve from the system, the following precautions must be taken:

The meter must be cleaned completely inside the housing components and stored/shipped as it was received.

1. Label all parts or place parts in labeled containers during disassembly.
2. Do not use metal clamping devices in direct contact with any control valve part or surface.

The control valve must be cleaned completely inside the housing components and stored/shipped as it was received. Refer to Storage Preparations for cleaning instructions.

After the meter is shut down, refer to [Cylinder disassembly \(NPS 2-12\)](#) for the detailed disassembly procedure.

After the previous steps have taken place, assemble the control valve per the instructions in [Mechanical assembly](#).

9.3.1 Cylinder disassembly (NPS 2-12)

Procedure

1. Remove the compression fitting and tubing from the port Y connection on the cylinder head.
2. Remove the nuts that secure the cylinder head to the valve body.
3. Alternately tighten the jack-out screws until the cylinder assembly is free to be lifted out of the valve body.
4. Lift the cylinder assembly by the cylinder head. Remove it from the valve body and set it in a vertical position with the cylinder head on top.
5. Before removing the screws, place the cylinder assembly in an arbor press to immobilize the cylinder head. This is to prevent sudden spring pressure from being released and causing injury or damage.



CAUTION

SPRING PRESSURE HAZARD

Follow the instructions in [Step 5](#).

Failure to comply may cause release of spring pressure, resulting in serious injury or equipment damage.

6. Use an Allen wrench to remove the screws that secure the cylinder head to the cylinder, and then gradually release the arbor press to remove the cylinder head from the cylinder. Remove the indicator guard and the upper bearing first, if your valve has a position indicator.
7. Remove the valve spring, indicator stem, retaining ring, washer, and piston from the cylinder. Remove only the valve spring and the piston if your valve does not have a position indicator.
8. With the cylinder in a vertical position (ports located on the top part of the cylinder), place the piston, nose end up, into the recess between the cylinder and the seat ring. Use an arbor press to push the piston into the cylinder, thus freeing the seat ring from the cylinder.

Figure 9-1: Using the piston to remove the seat ring from the 150/300 lb cylinder

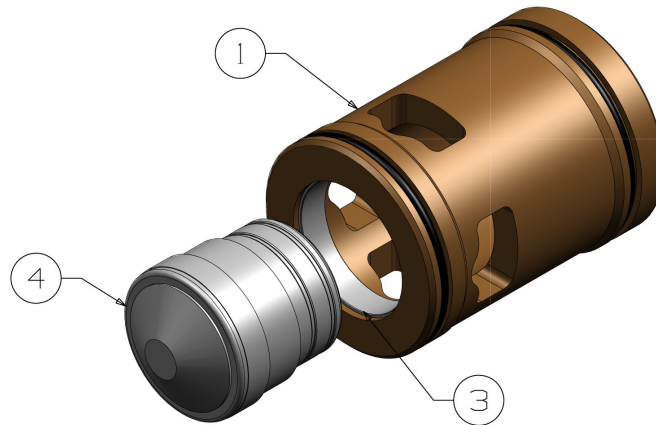

1. Cylinder
3. Seat ring
4. Piston

9. Turn the cylinder over with the ports on top when removing the high pressure seat ring. Remove the set screw from the seat ring. Turn the seat ring counterclockwise to remove the seat ring and then remove the O-ring from the cylinder.

9.3.2 Cylinder disassembly NPS 16 valve only

Important

The 16-in valve does NOT disassemble as a complete assembly. The first step is to remove the cylinder head from the valve body.

Prerequisites

The construction of the NPS 16 valve cylinder assembly is different from all other valve cylinder assemblies and requires different procedures. The following tools are needed to disassemble and reassemble the control valve.

- Socket wrench
- Adjustable wrench
- Extended allen wrench set
- Mallet and cold chisel
- Appropriate lifting gear and sling
- (2) all thread rods, $\frac{3}{4}$ -in no. 10x18-in to 24-in long
- (2) $\frac{3}{4}$ " no. 10x2-in bolts with $\frac{3}{4}$ -in flatwashers
- Hand pump

- Drip pan
- (3) hoist rings 1-in to 8-in nnc 10,000 lb, part number 1-504-90-094

Procedure

1. Completely block all product flow to the valve and drain the process line.
2. Disconnect "Y" port on top of cylinder head and relieve pressure in the valve.

Warning

SPRING FORCE HAZARD

Use extreme caution when removing the cylinder head from the valve body.

Failure to disassemble or reassemble the valve without carefully being aware of the force of the spring against the cylinder head may result in death, serious injury or damage to the equipment.



WARNING

SPRING TENSION HAZARD

Do not remove jack screws (long bolts). Jack screws are spring tension retaining devices and must NOT be tampered with. Follow disassembly procedure above.

Failure to comply with instructions may result in serious personal injury or damage to the equipment.

Figure 9-2: Model 700 Control Valve jack screws and spring

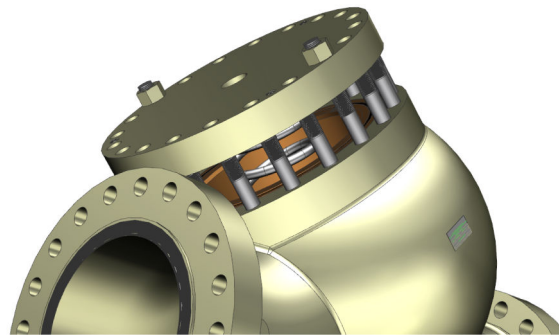

3. Product remains in the valve below the cylinder head in the piston. Place a drip pan below the valve before starting step 4 (removal of the cylinder head).
4. Remove nuts; except the jack screws (long bolts).
5. Alternatively, loosen the remaining two nuts from threaded rods allowing the cylinder head to slowly raise from the valve body and relieve spring tension. Oil from the piston will flow into drip pan. It is important to avoid damaging or bending the threaded rods during this operation.
6. Once spring tension is fully relieved, remove remaining nuts from threaded rods and lift cylinder head and reservoir away from threaded rods.
7. Remove spring from valve.
8. Use a hand pump to remove the remaining oil from the cylinder/piston assembly.
9. Insert (2) $\frac{3}{4}$ -in - 10 N.C. bolts with large washers behind bolt heads into threaded holes in the cylinder.

10. Use a chain or other suitable lifting device attached to the bolts and carefully remove the cylinder and piston from the valve body.
11. Secure the cylinder assembly and remove the piston from the cylinder by pushing the bottom of the piston.
12. Remove (24) bolts (item 12) while holding the seal ring to the cylinder. Remove the seal ring and the seat O-ring.
13. Inspect all components, remove any foreign material and replace O-rings, as necessary.

9.4 Mechanical assembly

9.4.1 Valve torque specifications

General fastener torque information

Product owners and users must realize that both time, and service conditions, impact the tightness and strength of fastener joint assemblies. Some, but not all, of these service conditions are:

- Time in service or storage
- Temperature cycles
- Vibration
- Mechanical loads
- Pressure loads
- Fastener thread condition (dirt/corrosion)
- Condition of joint assembly components (fasteners, gaskets, sealing surface conditions)
- Fastener lubrication and coatings

It is impossible for Emerson personnel to know all the variable conditions (some listed above) that your valve (under your care) will see in actual service. Only the owner or user, after careful consideration of a valve's service conditions, can specify a torque value to achieve an adequate seal.

The fastener assembly information provided here includes suggested torque value and sequencing instructions. Owners and users of the Emerson Daniel control valve should use this information to establish a starting point for applying torque to fasteners in service, or in repair, to achieve an adequate seal. Therefore, owners and operators are ultimately responsible for joint assembly torque specifications. Again, these values are only a reference.

Cylinder head/valve body torque information

In addition to the General fastener torque information, users should uniformly tighten the nuts that attach the Cylinder Head to the Valve Body using the suggested starting torque

values, sequencing patterns and application rates provided here to achieve an adequate seal.

Tighten each fastener at the following application rate:

- Install Nut - apply less than 20% of the suggested torque
- Second Pass - apply 20% - 30% of the suggested torque
- Third Pass - apply 30% - 70% of the suggested torque
- Fourth Pass - apply 100% of the suggested torque
- Fifth Pass - apply 100% of the suggested torque four (4) hours after Fourth Pass

Table 9-1: Valve cylinder head to body (stud-nut) suggested starting torque values by stud material⁽¹⁾⁽²⁾

B7M / L7M Stud size (in)	Suggested starting torque range lbf-ft (N·m)		B7 / L7 Stud size (in)	Suggested starting torque range lbf-ft (N·m)	
	Lower limit	Upper limit		Lower limit	Upper limit
3/8 - 16	21 (28)	24 (32)	3/8 - 16	28 (38)	31 (42)
7/16 - 14	27 (36)	30 (41)	7/16 - 14	35 (48)	39 (54)
1/2 - 13	41 (55)	45 (61)	1/2 - 13	53 (72)	59 (80)
5/8 - 11	79 (107)	88 (119)	5/8 - 11	103 (140)	115 (156)
3/4 - 10	137 (186)	153 (207)	3/4 - 10	180 (244)	200 (271)
7/8 - 9	218 (296)	243 (329)	7/8 - 9	287 (388)	319 (432)
1 - 8	325 (440)	361 (490)	1 - 8	426 (578)	474 (642)
1- 1/8 - 8	470 (638)	523 (708)	1-1/8 - 8	617 (837)	686 (930)
1-1/4 - 7	640 (867)	710 (963)	1-1/4 - 7	839 (1138)	932 (1264)
1-3/8 - 8	878 (1191)	976 (1323)	1-3/8 - 8	1153 (1563)	1281 (1737)

(1) Values are FOR REFERENCE only. Emerson provides the torque values in this table to help users establish a starting point to achieve an adequate unit assembly clamping force. Torque values reflect threads and nut bearing surfaces being bare metal well-lubricated with thread compound assembled in a controlled factory environment.

(2) The final torque required to achieve an adequate seal may be higher or lower than the range provided in this Table

Cylinder head/valve body torque sequencing patterns

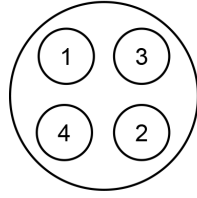

A

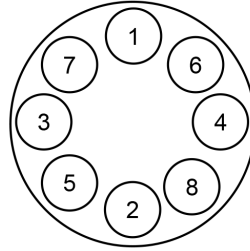

B

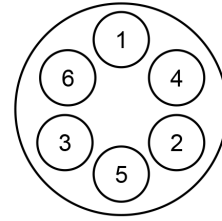

C

A.

- 2-in 150-300
— \emptyset 3/8-in Studs
- 2-in 600
— \emptyset 7/8-in Studs
- 3-in 150-300
— \emptyset 7/16-in Studs

B.

- 3-in 600
— \emptyset 7/8-in Studs
- 4-in 600
— \emptyset 5/8-in Studs
- 6-in 150-300
— \emptyset 1/2-in Studs
- 6-in 600
— \emptyset 3/4-in Studs

C. 4-in 150-300

- \emptyset 7/16-in Studs
-

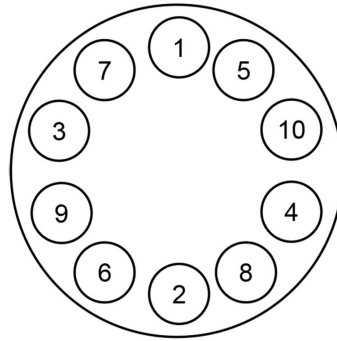

A

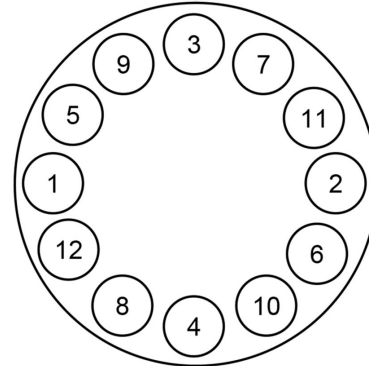

B

A. 8-in 150-300

- \emptyset $\frac{3}{4}$ -in Studs

B.

- 8-in 600
 - \emptyset $\frac{7}{8}$ -in Studs
- 10-in 150-300
 - \emptyset $\frac{7}{8}$ -in Studs
- 12-in 150-300
 - \emptyset $1\text{-}\frac{1}{8}$ -in Studs

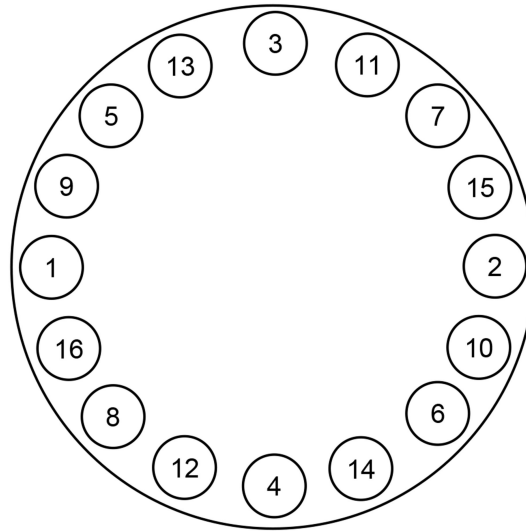

A

- A.
- 10-in 600
 - Ø 1-in Studs
 - 12-in 600
 - Ø 1-1/8-in Studs
-

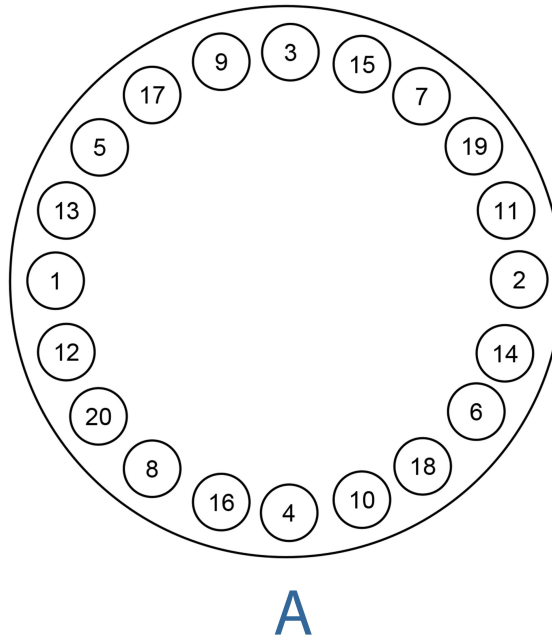

A.

- 12-in 900
 - Ø 1-1/4-in Studs
- 16-in 150-300
 - Ø 1-in Studs
- 16-in 600
 - Ø 1-3/8-in Studs

9.4.2 Standard cylinder reassembly

Reassembly of a control valve without a position indicator

Procedure

1. Place the cylinder in an upright position with the ports on the bottom. Lubricate the inside of the cylinder wall with a suitable lubricant.
2. Insert the O-ring into the groove inside the bottom of the cylinder. This will require some effort.
3. Insert the seat ring into the cylinder; placing it on top of the O-ring.
4. Using the piston as your tool, place its nose end down into the cylinder on top of the seat ring. Using a hammer handle or similar device, press down on the piston to force the seat ring into position against the lip in the cylinder.
5. Remove the piston from the cylinder.

6. With the piston in a vertical position, nose end down, place the O-ring into the groove on the piston. (If the valve is a high-pressure model, the piston will require PTFE backup rings on either side of the O-ring.)
7. Place the indicator stem retaining ring into the counter bore of the piston. Place the washer on top of the indicator stem retaining ring. Using retaining ring pliers, place the retaining ring on top of the washer.
8. Insert the piston into the cylinder, nose end down.
9. Insert the spring into the piston.
10. Turn the jack-out screws in the cylinder head to their original position.
11. Place the O-ring into the groove in the cylinder head.
12. Place the cylinder head on top of the spring, and use an arbor press against the top of the cylinder head to press the spring into the cylinder.



CAUTION

SPRING PRESSURE HAZARD

Follow the instructions in [Step 12](#).

Failure to comply may cause force to release the spring, resulting in serious injury or equipment damage.

13. Align the holes in the cylinder head with the mating holes in the cylinder and insert the screws into the holes in the cylinder head. Tighten the screws using an Allen wrench.
14. Remove the cylinder assembly from the arbor press.
15. Place the O-rings into the grooves in the outside of the cylinder.
16. Holding the cylinder assembly by the cylinder head, place the cylinder assembly into the valve body, aligning the holes in the cylinder head with the mating studs in the valve body. Tighten the nuts that secure the cylinder head to the valve body. If your valve does not have a position indicator, you have finished reassembling your valve.
17. Reconnect tubing to center of the cylinder head.

Reassembly of a control valve with a visual position indicator

Procedure

1. Place the valve in a vertical position with the cylinder head up. Place the indicator stem into the center hole in the cylinder head, and press it into the retaining ring in the piston. You may have to wiggle the indicator stem a little to get it into position. When the indicator stem is in position, you will not be able to pull it out.
2. Place the magnets onto the indicator stem, and retain the magnets by placing the retaining ring on the indicator stem.
3. Coat the threads of the indicator adapter with pipe sealant, and place the indicator adapter over the indicator stem, and screw it into the cylinder head. The connection for the tubing should face upwards.
4. Place the ring magnet on the indicator adapter.
5. Place the indicator housing over the indicator adapter, and secure it with the indicator top and screw.

Reassembly of a control valve with a microswitch-type position indicator

Procedure

1. Place the valve in a vertical position with the head up. Place the indicator stem into the center hole in the cylinder head, and press it into the retaining ring in the piston. You may have to wiggle the indicator stem a little to get it into position. When the indicator stem is in position, you will not be able to pull it out.
2. Install the indicator adaptor onto the cylinder head by turning the indicator guard clockwise. Stack the O-ring, seat retainer, the O-ring retainer, O-ring in the upper bearing, and place them onto the indicator stem.
3. Install the indicator guard on the indicator adaptor and secure it with the lockwashers and screws. Replace the two jack-out screws.

9.4.3 AP cylinder reassembly

Procedure

1. Protect the cup-seals against damage or distortion of any kind.
2. Install cup-seals with the closed ends facing “in”.
3. Cup-seal installation:
 - Place the inside edge of the bottom seal in the deep recess of the piston body (below the seal’s resting position) and carefully pull seal into position. Adjust cup-seal position into its proper location.
 - Ensure that the closed ends of the top cup-seal face “in” (back-to-back).

Retrofit a control valve

Applications requiring aggressive products need control valve modification. Use the following specific valve retrofitting procedure for these petroleum blending operations.

Upgrade existing AP units supplied prior to September, 1992

Three O-rings are supplied as a separate kit to upgrade existing valves, which have the original AP option (received prior to September 1992).

Procedure

1. Follow the procedures described in [Section 8.3.1](#) for general disassembly and [AP cylinder reassembly](#) for aggressive products cylinder reassembly.
2. Replace O-rings as required.
3. Complete the cylinder assembly by installing the piston and all the component parts through the top of the cylinder housing.

Important

Do not attempt to install the piston through the seat area. This will destroy the spring-loaded Teflon cup-seals.

4. For ease of installation, secure cylinder assembly to cylinder heads using hand pressure or arbor press.

 **WARNING**
DISASSEMBLY HAZARD

When performing any disassembly procedure caution is required as the cylinder head is bolted to a spring loaded cylinder assembly. Service should only be performed by trained and qualified service personnel.

Failure to follow these instructions could result in death, serious injury or damage to the equipment.

5. Lower the "new" cylinder assembly and cylinder head into the valve body. Align the bolt holes in the cylinder head with the studs in the main valve body.
6. Fasten the cylinder head into position using retaining nuts. Tighten nuts, alternating to opposite sides, to assure a uniform seat.
7. Return all tubing and/or valve accessories to their original position.

9.4.4 Cylinder reassembly (NPS 16 valve only)

Procedure

1. Reinstall seat O-ring and seal ring and tighten (24) bolts.

Important

Lightly coat the O-rings with a high grade lubricant to ensure proper seal. Inspect all O-rings for nicks, cuts, distortion or other signs of wear and replace as required.

2. Carefully reinstall piston into cylinder assembly.
3. Install outside cylinder O-ring.
4. Using $\frac{3}{4}$ -in - 10 bolts and suitable lifting device, reinstall cylinder and piston assembly back into valve body.
5. Remove $\frac{3}{4}$ -in - 10 bolts from cylinder. Reinstall spring into valve.
6. Reverse jack-out nut procedure to alternately tighten.
7. Reinstall cylinder head and reservoir to valve body.
8. Reinstall and tighten nuts.
9. Remove (2) long rods. Reinstall studs.
10. Re-establish nitrogen line connections to the valve.
11. Open all product flow to the valve.
12. Return the valve to service.

9.5 Planned maintenance tasks

Table 9-2: Planned maintenance tasks

Task	Recommended action
Inspect	Implement a periodic inspection program to ensure all parts are free from damage during its use due to process, ambient or other abnormal conditions. <ul style="list-style-type: none"> • Internal components: cylinder, piston, spring, cylinder head, seat retainer • Control valve body • Bolting
Clean	Use a non-toxic metal cleaning solvent. Do not use common petrochemical solvents like Benzene, Toluene or Xylene as they can pose potential health hazards.
Monitor corrosion / erosion / wear	A careful review of the control valve proving history, such as control valve factor control charts, can reveal potential problems bearing drag due to wear or increased internal cross-sectional area due to erosion.
Part (seal) replacement	Visual inspection of the O-rings is recommended once a year and replacement of the O-rings is recommended at least once every five years. Follow internal procedures for part replacement. Do not twist or overstretch the O-ring during assembly.
Corrosion monitoring	Daniel recommends visually inspecting the control valve for corrosion in the internal components at least once a year. Follow internal procedures for corrosion. The valve was designed without corrosion allowance. Periodically inspect the valve's metal parts for corrosion and erosion, and inspect the seals and O-rings for wear and chemical damage.
Lubricant information	High-viscosity silicone oil with a temperature range of -65° F to 400° F (-54° C to 204° C).
Proper lubrication procedure	Lubricate the entire surface of the O-ring before installation with a thin layer of high-viscosity silicone oil. Remove excess lubricant.

10 Corrective maintenance

10.1 Control valve troubleshooting

Use the table below to troubleshoot the control valve. Contact the nearest Emerson Flow services center for assistance with repairs of Daniel products. It is important that servicing be performed by trained and qualified service personnel.

Table 10-1: Troubleshooting issues of model 700 Control Valve

Condition	Probable cause	Correction ⁽¹⁾
Valve will not open	Upstream valve is closed	Open upstream valve.
	Pump is not operating	Start pump and check for cavitation.
	Downstream valve is closed	Open downstream valve. (Check coupler on bottom loading units and internal valve in truck.)
	Insufficient pressure	Check pump. Check bypass and strainer located in line.
	Clogged strainer	Clean strainer.
	Swollen O-rings	Disassemble valve and replace O-rings. Check compatibility of O-rings with product.
Valve opens too slowly	Valve inlet pressure below normal	Check strainer and pump for obstruction.
	Swollen O-rings	Disassemble valve and replace O-rings. Check compatibility of O-rings with product.
	Check "X" port sensitivity control needle valve position (maybe closed too much)	Open sensitivity control needle valve.
Valve will not close off tightly	Bent indicator stem	Replace indicator.
	Foreign material in main valve piston seat	Disassemble valve and inspect piston.
	Swollen O-rings	Disassemble valve and replace O-rings. Check compatibility of O-rings with product.
	Piston or seat O-ring cut or defective	Disassemble valve and replace if necessary.

(1) Refer to [Mechanical disassembly procedures](#).

10.2 Verify the return to operational condition

Once corrective maintenance has taken place, verify that the control valve is working properly by following the steps below.

Procedure

1. Inspect all bolts used to secure the control valve in-line to ensure that proper mounting procedures have been followed and that flange connections are leak-free.
2. Evaluate the system setup to ensure that all components are in the correct operating sequence.
3. Evaluate the system setup to ensure that all components are in the correct sequence for accurate product measurement. Some components are isolation valves, strainers, flow straighteners, turbine meters, downstream sections, etc.

11 Spare parts

11.1 Order spare parts

Contact Emerson Flow services for Daniel products and provide the following information when ordering parts:

- Daniel control valve serial number
- Part description
- Quantity

12 Decommission

12.1 Shut down the control valve

Follow the steps below to shut down and disassemble the control valve for storage or shipment.



WARNING

PRESSURE HAZARD

The control valve is subject to pressurized fluids. Isolate the control valve upstream and downstream.

Always depressurize the control valve before disassembly.

Failure to comply may cause high pressure fluids to leak, resulting in death or serious injury.

Procedure

1. Ensure that the valve is free of contaminants.
2. Drain the valve of liquids.
3. Clean the valve components.
4. Label all parts or place parts in labeled containers during disassembly.
5. Do not use metal clamping devices in direct contact with control valve parts or surfaces.

Refer to [Mechanical disassembly](#) after shutting down the control valve.

12.2 Shipment of the control valve

Refer to Emerson Flow services for Daniel products information in the preface of this document.

Emerson Automation Solutions

7070 Winchester Circle
Boulder, Colorado USA 80301
T: +1 800-522-6277
T: +1 303-527-5200
F: +1 303-530-8459
Mexico: +52 55 5809 5300
Argentina: +54 11 4837 7000
Brazil: +55 15 3413 8000
Chile: +56 2 2928 4800
Peru: +51 15190130
www.emerson.com

Emerson Automation Solutions

Central Europe: +41 41 7686 111
Eastern Europe: +41 41 7686 111
Dubai: +971 4 811 8100
Abu Dhabi: +971 2 697 2000
Austria: +43 2236 607-0
France: +33 (0) 800 917 901
Germany: +49 (0) 2173 3348 0
Italy: +39 8008 77334
The Netherlands: +31 318 495 555
Belgium: +32 2 716 77 11
Spain: 900 901 983
U.K. and Ireland: 0870 240 1978
Russian/CIS: +7 495 995 9559

Emerson Automation Solutions

Australia: (61) 3 9721 0200
China: (86) 21 2892 9000
India: (91) 22 6662 0566
Japan: (81) 3 5769 6803
South Korea: (82) 31 8034 0000
Singapore: (65) 6 363 7766

©2020 Daniel. All rights reserved. Unauthorized duplication in whole or part is prohibited. Printed in the USA.

Daniel™ ("Daniel") is an Emerson Automation Solutions brand. The Daniel name and logo are trademarks of Emerson. The Emerson logo is a trademark and service mark of Emerson Electric Co. All other trademarks are the property of their respective companies.