

Daniel™ Series 1500

Liquid Turbine Flow Meter



Series 1500 Liquid Turbine Meter

Custody Transfer Reliability

Reliable 24/7 operation combined with linear, repeatable measurement make the Daniel Series 1500 Liquid Turbine Meter the instrument of choice for custody transfer volumetric flow measurement. Engineered for demanding crude oil and refined product applications, the durable meter now features potted electronics that endure significant vibration and shock along with rugged internals for steady, long-term performance.

The unique design of the meter's stainless steel internal assembly features a dual-hanger suspension system that supports the assembly both upstream and downstream. The system also centers and balances the rotor in the flow tube and provides for positive bearing lubrication, resulting in maximum volume throughput and minimum pressure drop. In addition, standard tungsten carbide journal bearings ensure nearly frictionless rotor movement and deliver exceptional longevity.

The meter's new local mounted enclosure (LME) is configured with two pickoff coils and a standard dual-channel preamplifier that is now encased in an epoxy resin (potted), enabling it to withstand vibration, shock and harsh environments. The combination of two pickoffs and the dual-channel preamplifier in each LME guarantees pulse integrity and virtually eliminates the potential for missing or double-counted pulses. For complete measurement redundancy, a second LME can be added to achieve four matched pulse outputs, enabling the meter to accommodate a wide variety of metering and proving requirements.

API Compliant

The Series 1500 Liquid Turbine Flow Meter is specifically designed for pipeline operation and for use within the guidelines of the API Manual of Petroleum Measurement Standards (MPMS), Chapter 5.3 (Measurement of Liquid Hydrocarbons by Turbine Meter) and the calibration procedures of MPMS, Chapter 4 (Proving Systems).



Figure 1: Daniel 1500 Liquid Turbine Flow Meter

Typical Applications

- Crude oil and refined product pipelines
- Custody transfer and check metering
- Crude oil production
- In-line refined product blending
- Tank farm/storage inventory control
- Tank ship and rail car loading and off-loading
- Floating storage and off-loading (FSO)
- Floating production, storage and off-loading (FPSO)

Features and Benefits

- Available in DN 25 to 600 (1 to 24-in) line sizes
- Pulse output linear with flow rate and 10:1 rangeability (turndown) ensure custody transfer accuracy
- High-frequency pulse resolution enables measurement of minute increments of flow rate for greater accountability
- Stainless steel internal assembly ensures maximum volume throughput and minimum pressure drop
- Tungsten carbide bearings guarantee durability and longevity with minimal maintenance required
- Local mounted enclosure (LME) configured with two pickoffs and a standard dual-channel preamplifier for total pulse integrity
- Dual LME configuration offers four pulse outputs in two pairs that are each 90° electrically out-of-phase for complete redundancy and reliability
- Electronics designed for easy access to pickoffs and preamplifier to simplify service
- LME housing is explosion and weather proof for safe operation within refineries and harsh environments

A Range of Available Options

- Stainless or carbon steel meter body
- DN 25 to 600 (1 to 24-in) line sizes
- Rimmed, bladed or light product rotors
- Bi-directional flow
- NACE MR0175-compliant construction
- Single or dual LME
- DRT-899 Flow/Rate Totalizer with backlit local display

Specifications

The standard performance parameters and materials of construction are noted. Additional product and material offerings may be available depending on the application. Please consult with a Daniel representative to confirm.

Process Parameters

Table 1: Temperature Ranges		
	Carbon Steel	304/316 Stainless Steel
Standard ⁽¹⁾	-29°C to +60°C (-20°F to +140°F)	-40°C to +60°C (-40°F to +140°F)
High Temperature	-29°C to +204°C (-20°F to +400°F)	-40°C to +204°C (-40°F to +400°F)

Table 2: Linearity				
DN	Size (Inches)	Standard Linearity	Premium Linearity	Repeatability
25 to 65	1 to 2.5	±0.25%	±0.15%	±0.02%
80 to 600	3 to 24	±0.15%	±0.1%	±0.02%
			±0.07% (5:1 Turndown)	±0.02%

Table 3A: Flange Pressure Ratings (Metric Units)		
PN	Pressure Rating, barg at +38°C	
	Carbon Steel	304/316 Stainless Steel
20	19.6 bar	19.0 bar
50	51.0 bar	49.6 bar
100	102.0 bar	99.3 bar
150	153.1 bar	148.9 bar
250	255.4 bar	248.2 bar
420	425.4 bar	413.7 bar

Table 3B: Flange Pressure Ratings (US Customary Units)		
ANSI Class	Pressure Rating, psig at +100°F	
	Carbon Steel	304/316 Stainless Steel
150	285 psi	275 psi
300	740 psi	720 psi
600	1,480 psi	1,440 psi
900	2,220 psi	2,160 psi
1,500	3,705 psi	3,600 psi
2,500	6,170 psi	6,000 psi

Safety and Compliance

Electrical

- UL / cUL Class I, Division 1, Groups B, C and D
- ATEX: Ex d IIC T6 Gb
- IECEX: Ex d IIC T6 Gb
- INMETRO: BR- Ex d IIC T6 Gb

Environmental

- NEMA 4X (IEC IP66)

Metrology

- NMi TC7573, Revision 2

Table 4A: Maximum Allowable Pressure at Temperature (Metric Units)						
Temperature	PN Class Carbon Steel Flanges (barg)					
	20	50	100	150	200	250
< +38°C	19.7	51.0	102.0	153.1	255.5	425.4
+93°C	17.9	46.9	93.8	140.3	234.1	389.9
+149°C	15.9	45.2	90.3	135.5	225.5	375.8
+204°C	13.8	43.8	87.2	131.0	218.6	364.0

Table 4B: Maximum Allowable Pressure at Temperature (US Customary Units)						
Temperature	ANSI Class Carbon Steel Flanges (psig)					
	150	300	600	900	1,500	2,500
< +100°F	285	740	1,480	2,220	3,705	6,170
+200°F	260	680	1,360	2,035	3,395	5,655
+300°F	230	655	1,310	1,965	3,270	5,450
+400°F	200	635	1,265	1,900	3,170	5,280

(1) Remote mounted enclosure (RME) and high temperature options required for ambient temperatures >+60°C (+140°F) or for process temperatures ≥+85°C (+185°F).

Standard Flow Ranges

The linearity specification is dependent on the characteristics of the calibration fluid. For DN25 to 200 (1 to 8-in) meters, SG is 0.78 and KinVisc (cSt) is 2.1. For DN250 to 600 (10 to 24-in) meters, SG is 1.0 and KinVisc (cSt) is 1.0.

Table 5: Linear Flow Range⁽¹⁾

Nominal Size		BBL/HR			M ³ /HR			USGPM			
DN	Inches	Standard Flow Range		Extended Max Flow Rate ⁽²⁾	Standard Flow Range		Extended Max Flow Rate ⁽²⁾	Extended Min Flow Rate Linearity 0.75% (1"-2.5") 0.50% (3"-24")	Standard Flow Range		Extended Max Flow Rate ⁽²⁾
		Min	Max		Min	Max			Min	Max	
25	1	10	100	115	1.6	16	18	5.6	7	70	81
40	1.5	21	214	246	3.4	34	39	12	15	150	173
50	2	43	429	493	6.8	68	78	24	30	300	345
65	2.5	57	571	657	9.1	91	105	32	40	400	460
80	3	100	1,000	1,150	15.9	159	183	56	70	700	805
100	4	185	1,850	2,128	29.4	294	338	104	130	1,295	1,489
150	6	420	4,200	4,830	66.8	668	768	235	294	2,940	3,381
200	8	850	8,500	9,775	135	1,351	1,554	476	595	5,950	6,843
250	10	1,200	12,000	13,800	191	1,908	2,194	672	840	8,400	9,660
300	12	1,800	18,000	20,700	286	2,862	3,291	1,008	1,260	12,600	14,490
400	16	2,800	28,000	32,200	445	4,452	5,120	1,568	1,960	19,600	22,540
450	18	4,000	40,000	46,000	636	6,359	7,313	2,240	2,800	28,000	32,200
500	20	4,800	48,000	55,200	763	7,631	8,776	2,688	3,360	33,600	38,640
600	24	6,000	60,000	69,000	954	9,539	10,970	3,360	4,200	42,000	48,300

Table 6: Nominal K-Factor⁽³⁾

Nominal Size		Pulses/BBL		Pulses/M ³		Pulses/US Gal	
DN	Inches	Blade	Rim	Blade	Rim	Blade	Rim
25	1	21,000	N/A	132,086	N/A	500	N/A
40	1.5	9,660		60,760			
50	2	5,460		34,342			
65	2.5	2,730		17,171			
80	3	2,100	4,620	13,209	29,059	50	110
100	4	1,000	2,940	6,287	18,492	24	70
150	6	245	1,050	1,532	6,604	5.8	25
200	8	N/A	550	N/A	3,461	N/A	13
250	10		250		1,585		6.0
300	12		200		1,268		4.8
400	16		100		634		2.4
450	18		100		634		2.4
500	20		100		634		2.4
600	24		100		634		2.4

(1) Bi-directional meters have a standard linear flow range as stated above. The minimum flow rate in the reverse direction is 20% of its maximum extended flow rate.

(2) Extended flow rate with 20% duty cycle not to exceed 2 hours per day.

(3) K-Factors for individual rotors vary. An acceptable rotor can be nominal $\pm 15\%$.

Flow Range Adjustments

The tables below represent the effect of specific gravity on the linear flow range.

Table 7A: Specific Gravity = 0.7 to 1 (Blade and Rim Type Internals)							
Nominal Size		Minimum Linear Flow Rate			Maximum Linear Flow Rate		
DN	Inches	BBL/HR	M ³ /HR	USGPM	BBL/HR	M ³ /HR	USGPM
25	1	10	1.6	7	100	15.9	70
40	1.5	21	3.4	15	214	34.1	150
50	2	43	6.8	30	429	68.1	300
65	2.5	57	9.1	40	571	90.9	400
80	3	100	15.9	70	1,000	159	700
100	4	186	29.5	130	1,850	294	1,295
150	6	420	66.8	294	4,200	668	2,940

Table 7B: Specific Gravity = 0.6 (Blade Type Internals Only)							
Nominal Size		Minimum Linear Flow Rate			Maximum Linear Flow Rate		
DN	Inches	BBL/HR	M ³ /HR	USGPM	BBL/HR	M ³ /HR	USGPM
25	1	17	2.7	12	116	18.4	81
40	1.5	36	5.7	25	247	39.3	173
50	2	71	11.4	50	493	78.4	345
65	2.5	96	15.2	67	657	105	460
80	3	167	26.6	117	1,150	183	805
100	4	309	49.1	216	2,129	338	1,490
150	6	701	112	491	4,830	768	3,381

Table 7C: Specific Gravity = 0.5 (Blade Type Internals Only)							
Nominal Size		Minimum Linear Flow Rate			Maximum Linear Flow Rate		
DN	Inches	BBL/HR	M ³ /HR	USGPM	BBL/HR	M ³ /HR	USGPM
25	1	23	3.6	16	116	18.4	81
40	1.5	50	7.9	35	247	39.1	172
50	2	101	16.1	71	493	78.4	345
65	2.5	134	21.3	94	657	105	460
80	3	236	37.5	165	1,150	183	805
100	4	436	69.3	305	2,129	338	1,490
150	6	989	157	692	4,830	768	3,381

Table 7D: Specific Gravity = 0.4 (Blade Type Internals Only)							
Nominal Size		Minimum Linear Flow Rate			Maximum Linear Flow Rate		
DN	Inches	BBL/HR	M ³ /HR	USGPM	BBL/HR	M ³ /HR	USGPM
25	1	29	4.5	20	116	18.4	81
40	1.5	60	9.5	42	246	39.1	172
50	2	120	19.1	84	493	78.4	345
65	2.5	160	25.4	112	657	105	460
80	3	280	44.5	196	1,150	183	805
100	4	517	82.2	362	2,129	338	1,489
150	6	1,173	187	821	4,830	768	3,381

Table 7E: Specific Gravity = 0.3 (Blade Type Internals Only)							
Nominal Size		Minimum Linear Flow Rate			Maximum Linear Flow Rate		
DN	Inches	BBL/HR	M ³ /HR	USGPM	BBL/HR	M ³ /HR	USGPM
25	1	33	5.2	23	116	18.4	81
40	1.5	71	11.4	50	246	39.1	172
50	2	141	22.5	99	493	78.4	345
65	2.5	190	30.2	133	657	105	460
80	3	331	52.7	232	1,150	183	805
100	4	613	97.4	429	2,129	338	1,489
150	6	1,393	221	975	4,830	768	3,381

Pressure Drop

The pressure drop characteristics on water for the Series 1500 Liquid Turbine Meter by line size.

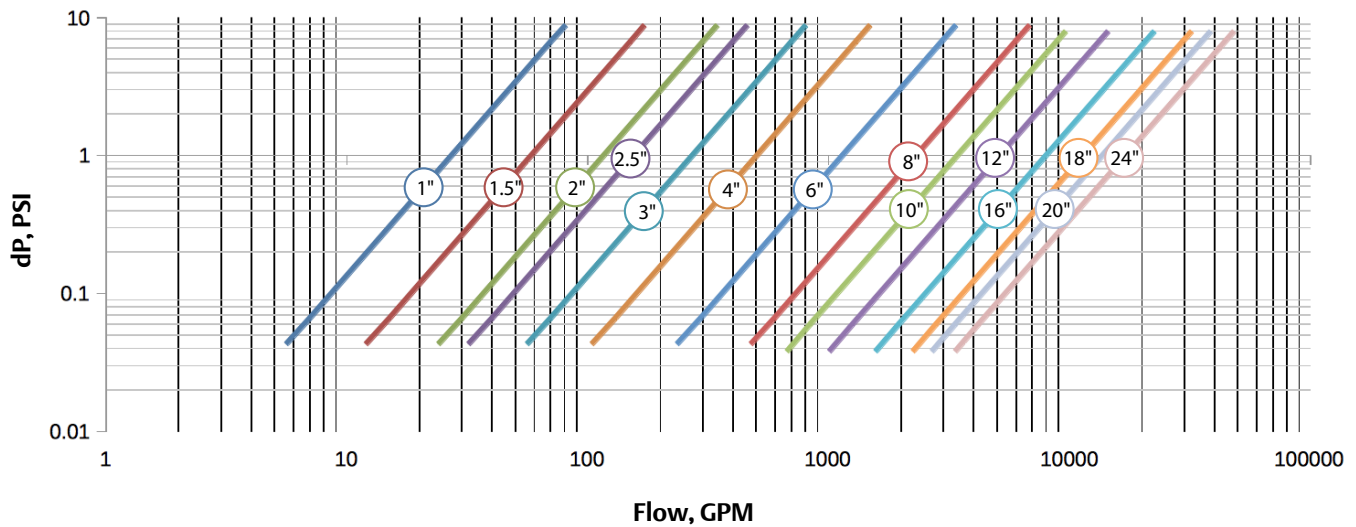

Figure 2: Pressure Drop Chart

High Viscosity Liquids

Increases in viscosity of the measured liquid will reduce the rangeability of the Series 1500 flow meter. Generally, the minimum flow rate of the meter will have to be increased to maintain the linearity rating of the meter.

The increased flow rate may be determined according to the following ratio:

$$\text{Sizing Ratio} = \frac{\text{Liquid Viscosity (Centistokes)}}{\text{Nominal Line Sizes}}$$

Table 8: Minimum Flow Rate	
Sizing Ratio	Minimum Flow (% of Normal Maximum Flow Rate)
1	Use Normal Minimum Flow Rate
1.5	20%
2	25%
2.5	30%
3	35%
4	40%
5	45%
6	50%
7	55%
8	60%

Example:

The sizing ratio of a 4-inch turbine meter measuring a liquid of 8 cSt is 8/4, or 2. The normal maximum flow rate of this meter size is 1295 GPM. The new minimum flow rate is 25% of 1295, or 324 GPM. The flow rate for this application is now 324 to 1295 GPM, with standard linearity ($\pm 0.15\%$) and repeatability ($\pm 0.02\%$) maintained.

Note:

Use of the turbine meter on high viscosity liquids at the maximum extended flow range is allowable, but may increase the wear rate of the turbine.

The pressure drop through the meter may be estimated (for low to medium viscosities) according to the following formula:

$$DP = (PD) \times (\mu)^{1/4} \times (SG)^{3/4} \quad \text{or} \quad DP = (PD) \times (v)^{1/4} \times (SG)$$

Where:

- DP = Estimated pressure drop
- PD = Pressure drop for water at expected flow rate
- μ = Absolute viscosity in centipoises
- v = Kinematic viscosity in centistokes
- SG = Specific gravity

Note: $\mu = (v) \times (SG)$

Electrical

Preamplifiers

The new local mounted enclosure (LME) on the Daniel Series 1500 Liquid Turbine Meter contains a standard dual-channel preamplifier and two inductive pickoff coils. These coils have the sensitivity to provide accurate detection of rotor travel and have output with electrical characteristics of high impedance and low voltage. Noise-free transmission of the flow signals requires the opposite: low impedance and high voltage. This is the function of the signal preamplifier. Located within 5 meters (16.4 feet) of the pickoff coil, turbine meter preamplifiers shape and condition the pickoff output signal, rendering it suitable for transmission over distances of up to 914 meters (3,000 feet).

Available Models

Standard

- **The Model 2818 Dual Channel Preamplifier** is the standard Daniel offering for most liquid turbine meter applications. The signals from two inductive pickoff coils, positioned 90° electrically out of phase, are strengthened and conditioned by a single preamplifier. Fully potted in Delrin® resin, the Model 2818 has three possible outputs: powered pulse, variable voltage and open collector.
- **The Model 2415 Intrinsically Safe Preamplifier** is for hazardous area use (Zone 0).
- **The Model 1815B Zero Crossing Preamplifier** produces an output pulse with each zero crossing of the input signal. It is high resolution, producing twice the pulses from a single pickoff.
- **The Model 1817X2 Bi-Directional Preamplifier** is used on liquid turbine meters when the requirement is to accumulate flow in both forward and reverse directions.

Optional

- Additional preamplifier models are available. Consult with a Daniel representative to confirm the best model for the application.

Electrical Performance

Pickoff Specifications

- Type: 2-wire reluctance
- Resistance: 600 - 900 ohms
- Inductance: 250mH max
- Output: Sinusoidal 40mV p-p minimum @minimum flow with preamplifier load
- Optional: 2 pickoff coils (single or dual LME) or 4 pickoff coils (dual LME required)

Table 9: 2818 Dual Channel Preamplifier Jumper Configurations

Jumper	Jumper Positions		
	A	B	Out
J1-Chan. A Input	NA	40mV. PP Min	NA
J2-Chan. B Input	NA	40mV. PP Min	NA
J3-Chan. A Output	5v.Pulse	Sup. Volt. Pulse (10-30 VDC)	O.C.
J4-Chan. B Output	5v.Pulse	Sup. Volt. Pulse (10-30 VDC)	O.C.

Table 10: Standard Preamplifiers

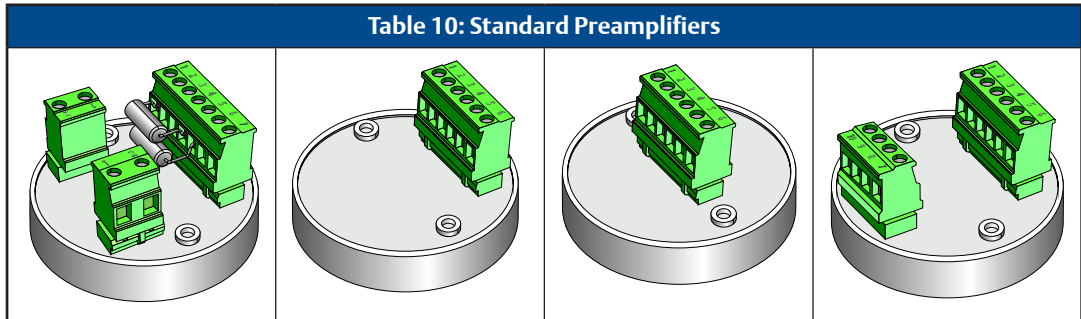

DESCRIPTION	Dual Channel	Intrinsically Safe	Zero Crossing	Bi-Directional
MODEL	2818	2415	1815B	1817X2
Daniel Part #	1-504-05-550	1-504-05-449	1-504-05-510	1-504-05-442
INPUTS				
# of Inputs (Pickoffs):	2	1	1	2
Supply Voltage:	10 to 30 VDC	11.5 to 25 VDC	12 to 30 VDC	11.5 to 36 VDC
Sensor Type:	Reluctance	Reluctance	Reluctance	Reluctance
Signal:	Sine Wave	Sine Wave	Sine Wave	Sine Wave
Current:	10 to 30 VDC @ 40 mA p-p	< 12 mA	10 mA @ 15V	11.5 to 36 VDC < 30 mA
Preamplifier Sensitivity:	40 mVpp	10 Hz to 1 KHz (60mV p-p) 10 Hz to 3 KHz (60mV p-p) 10 Hz to 1 KHz (60mV p-p)	40 mV peak-to-peak	40 mV peak-to-peak
Frequency Response:	0 to 5 kHz	5 Hz to 5 kHz	0 to 5 kHz	5 Hz to 5 kHz
OUTPUT (POWERED PULSED)				
Type:	Square wave	Square wave	Square wave	Square wave
Frequency Range:	≤ 0 to 5 kHz	≤ 5 Hz to 5 kHz	≤ 5 kHz	≤ 5 Hz to 5 kHz
Amplitude:	0 to 5 V	0 to 5 V	0 to 12 V	0 to Vs
Impedance:	1000 Ohm, 20 mA max	20000 Ohm	300 Ohm	O.C.
CONSTRUCTION	Delrin Housing Solid Epoxy Encapsulation	Delrin Housing Solid Epoxy Encapsulation	Delrin Housing Solid Epoxy Encapsulation	Delrin Housing Solid Epoxy Encapsulation
TEMPERATURE RANGE	-40°C to +85°C (-40°F to +185°F)	-40°C to +85°C (-40°F to +185°F)	-40°C to +85°C (-40°F to +185°F)	-40°C to +85°C (-40°F to +185°F)
CUSTOMER CONNECTION				
Terminal Block 1 (TB1):	(1) +10 to 30 VDC (2) Common (3) Common (4) Channel A Output (5) Channel B Output (6) TTL Out A (7) TTL Out B	(1) 11.5 to 25 VDC (2) Common (3) Signal Out (Half-Freq) (4) Signal Out	(1) 12 to 30 VDC (2) Common (3) Output Signal (x1) (4) Output Signal (x2)	(1) 11.5 to 36 VDC (2) Common (3) Direction (4) Channel A Out (5) Channel B Out (6) Prover Out (x2)
PICKOFFS				
Channel A (TB2):	(1) White (2) Red	(5) White (6) Red	(5) White (6) Red	(1) White (2) Red
Channel B (TB3):	(1) White (2) Red			(1) White (2) Red

Product Diagrams

Local Mounted Enclosure (LME)

Configuration shown for temperature up to +60°C (+140°F)

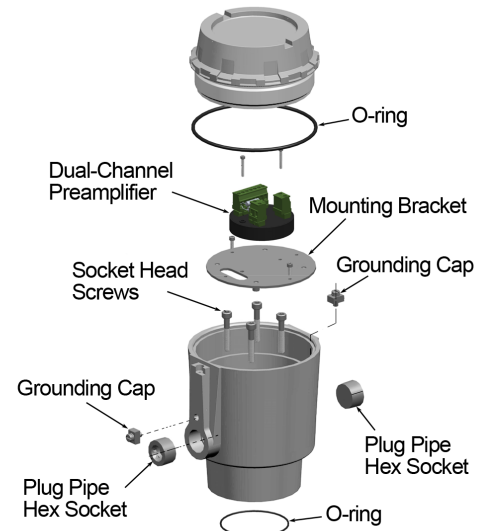

Rim Type Rotor

Available in DN 80 to 600 (3 to 24 in)

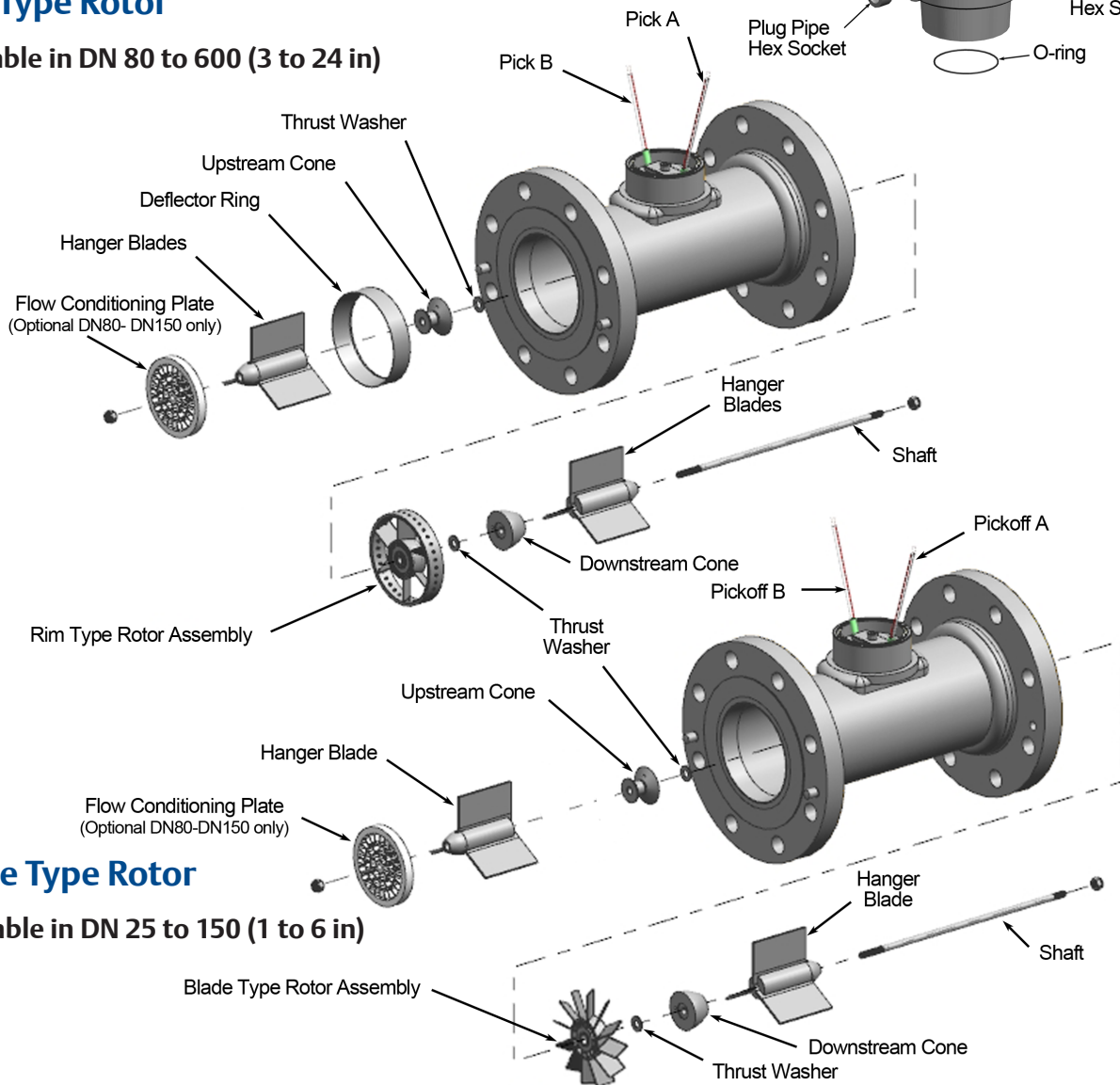

Blade Type Rotor

Available in DN 25 to 150 (1 to 6 in)

Materials of Construction

Standard Materials

Table 11A: Meter with Bladed Rotor (DN 25 to 150 / 1" to 6")			
Meter Body and Flanges	Carbon Steel	Stainless Steel (304SS)	Stainless Steel (316SS)
Local Mounted Electronics (LME)	316SS	316SS	316SS
Blades			
DN 25 (1")	430SS / 304SS / 316SS	430SS / 304SS	NICKEL-200 / 316SS
DN 40 to 150 (1.5" to 6")	430SS / NICKEL-200 ⁽¹⁾	430SS	NICKEL-200 ⁽¹⁾
Rotor Hub			
DN 25 to 150 (1" to 6")	430SS / 316SS	430SS	316SS
Shaft			
DN 25 to 65 (1" to 2.5")	316SS	316SS	316SS
DN 80 to 150 (3" to 6")	17-4 PH SS HT ⁽²⁾	17-4 PH SS HT ⁽²⁾	17-4 PH SS HT ⁽²⁾
Tolerance Rings (DN 65 to 600 / 2.5" to 24")	K-MONEL	K-MONEL	K-MONEL
Bearing Set	Tungsten Carbide	Tungsten Carbide	Tungsten Carbide
Suspension	304SS / 316SS	304SS	316SS
Cones	304SS / 316SS	304SS	316SS

Table 11B: Meter with Rimmed Rotor (DN 80 to 600 / 3" to 24")			
Meter Body and Flanges	Carbon Steel	Stainless Steel (304SS)	Stainless Steel (316SS)
Local Mounted Electronics (LME)	316SS	316SS	316SS
Blades	304SS / 316SS	304SS	316SS
Rotor Hub	430SS / 316SS	430SS	316SS
Rotor Rim			
DN 80 to 100 (3" to 4")	316SS	316SS	316SS
DN 150 to 600 (6" to 24")	304SS / 316SS	304SS	316SS
Shaft	17-4 PH SS HT ⁽²⁾	17-4 PH SS HT ⁽²⁾	17-4 PH SS HT ⁽²⁾
Tolerance Rings	K-MONEL	K-MONEL	K-MONEL
Bearing Set	Tungsten Carbide	Tungsten Carbide	Tungsten Carbide
Suspension	304SS / 316SS	304SS	316SS
Deflector Ring	304SS / 316SS	304SS	316SS
Rim Buttons	Mu-Metal	Mu-Metal	Mu-Metal
Cones	304SS / 316SS	304SS	316SS

Table 11C: Meter with Lightweight Rotor (DN 80 to 300 / 3" to 12")			
Meter Body and Flanges	Carbon Steel	Stainless Steel (304SS)	Stainless Steel (316SS)
Local Mounted Electronics (LME)	316SS	316SS	316SS
Blades			
DN 80 to 100 (3" to 4") (Blade Type)	430SS	430SS	430SS
DN 150 to 300 (6" to 12") (Rim Type)	304SS	304SS	304SS
Rotor Hub			
DN 80 (3")	430SS	430SS	430SS
DN 100 to 300 (4" to 12")	6061-T6 ALUM	6061-T6 ALUM	6061-T6 ALUM
Shroud (DN 150 to 300 / 6" to 12")	430SS	430SS	430SS
Shaft	17-4 PH SS HT ⁽²⁾	17-4 PH SS HT ⁽²⁾	17-4 PH SS HT ⁽²⁾
Tolerance Rings	K-MONEL	K-MONEL	K-MONEL
Bearing Set	Tungsten Carbide	Tungsten Carbide	Tungsten Carbide
Suspension	304SS / 316SS	304SS	304SS
Deflector Ring	304SS / 316SS	304SS	316SS
Cones	304SS / 316SS	304SS	304SS

NOTE: Teflon Coated rotor available for Rim and Blade type.

(1) Rim type rotor not recommended, use blade type rotor only.

(2) For full NACE MR0175:2002 compliancy, material will change to 316SS with hard chrome or optional full NACE MR175/ISO151: 2003.

NACE MR0175 2003 Compliant Materials

Table 11D: Meter with Bladed Rotor (DN 25 to 150 / 1" to 6")			
Meter Body /Flanges	Carbon Steel	Stainless Steel (304SS)	Stainless Steel (316SS)
Local Mounted Electronics (LME)	316SS	316SS	316SS
Blades			
DN 25 (1")	430SS / 304SS	430SS / 304SS	430SS / 304SS
DN 40 to 150 (1.5" to 6")	430SS	430SS	430SS
Rotor Hub	430SS	430SS	316SS
Shaft			
DN 25 to 65 (1" to 2.5")	316SS	316SS	316SS
DN 80 to 150 (3" to 6")	316SS with Hard Chrome ⁽¹⁾	316SS with Hard Chrome ⁽¹⁾	316SS with Hard Chrome ⁽¹⁾
Tolerance Rings (DN 65 to 600 / 2.5"-24")	K-MONEL	K-MONEL	K-MONEL
Bearing Set	Tungsten Carbide	Tungsten Carbide	Tungsten Carbide
Suspension	304SS	304SS	316SS
Cones	304SS	304SS	316SS

Table 11E: Meter with Rimmed Rotor (DN 80 to 600 / 3" to 24")			
Meter Body and Flanges	Carbon Steel	Stainless Steel (304SS)	Stainless Steel (316SS)
Local Mounted Electronics (LME)	316SS	316SS	316SS
Blades	304SS	304SS	316SS
Rotor Hub	430SS	430SS	316SS
Rotor Rim			
DN 80 to 100 (3" to 4")	316SS	316SS	316SS
DN 150 to 600 (6" to 24")	304SS	304SS	316SS
Shaft	316SS with Hard Chrome ⁽¹⁾	316SS with Hard Chrome ⁽¹⁾	316SS with Hard Chrome ⁽¹⁾
Tolerance Rings	K-MONEL	K-MONEL	K-MONEL
Bearing Set	Tungsten Carbide	Tungsten Carbide	Tungsten Carbide
Suspension	304SS	304SS	316SS
Deflector Ring	304SS	304SS	316SS
Rim Buttons	Mu-Metal	Mu-Metal	Mu-Metal
Cones	304SS	304SS	316SS

NOTE: Teflon coated rotor available for Rim and Blade type.

(1) For full NACE MR0175:2002 compliancy, material will change to 316SS with hard chrome or optional full NACE MR175/ISO151: 2003.

Weights and Dimensions

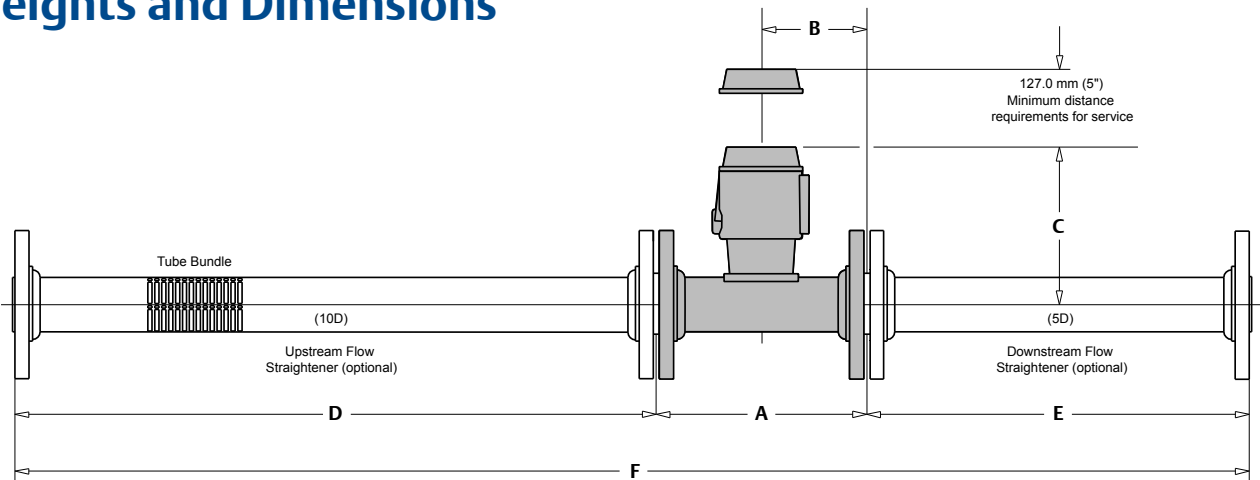

Table 12: Daniel 1500 Liquid Turbine Flow Meter and Flow Straightening Sections⁽¹⁾

Sizes		A		B		C		D		E		F	
DN	Inches	MM	INCHES	MM	INCHES	MM	INCHES	MM	INCHES	MM	INCHES	MM	INCHES
25 ⁽²⁾	1 ⁽²⁾	203	8	102	4	259	10	508	20	127	5	841	33
40 ⁽²⁾	1.5 ⁽²⁾	229	9	114	4.5	269	11	762	30	191	8	1,184	47
50	2	229	9	114	4.5	269	11	508	20	254	10	994	39
65	2.5	254	10	127	5	279	11	635	25	318	13	1,210	48
80	3	254	10	127	5	279	11	762	30	381	15	1,400	55
100	4	305	12	152	6	297	12	1,016	40	508	20	1,832	72
150	6	356	14	178	7	325	13	1,524	60	762	30	2,645	104
200	8	406	16	203	8	351	14	2,032	80	1,016	40	3,458	136
250	10	508	20	254	10	376	15	2,540	100	1,270	50	4,321	170
300	12	610	24	305	12	401	16	3,048	120	1,524	60	5,185	204
400	16	813	32	406	16	445	18	4,064	160	2,032	80	6,912	272
450	18	914	36	457	18	470	19	4,572	180	2,286	90	7,776	306
500	20	1,016	40	508	20	495	20	5,080	200	2,540	100	8,639	340
600	24	1,219	48	610	24	546	22	6,096	240	3,048	120	10,366	408

(1) Dimension A applies to 150# - 900# ANSI LTMs. For 1500# and 2500# ANSI LTMs, Consult Factory.
 (2) DN 25 and 40 (1" and 1.5") sizes do not use Straightening Vanes for Flow Conditioning. These sizes employ a 20 Diameter Upstream Section.

Table 13: Approximate Shipping Weight with Single Stainless Steel LME⁽¹⁾

Sizes		ANSI Class 150 RF		ANSI Class 300 RF		ANSI Class 600 RF & RTJ		ANSI Class 900 RF & RTJ		ANSI Class 1500 RF & RTJ		ANSI Class 2500 RTJ	
DN	Inches	kg	lbs	kg	lbs	kg	lbs	kg	lbs	kg	lbs	kg	lbs
25	1	9.6	21	10.6	23	11.6	26	18.6	41	18.6	41	CF	CF
40	1.5	12.6	28	14.1	31	15.6	34	25.9	57	25.9	57	CF	CF
50	2	13.6	30	14.6	32	16.6	37	35.4	78	35.4	78	CF	CF
65	2.5	17.6	39	20.6	45	22.6	50	45.3	100	45.3	100	CF	CF
80	3	19.1	42	23.6	52	25.6	56	53.6	118	65.7	145	CF	CF
100	4	25.6	56	35.6	78	44.1	97	66.6	147	96.0	211	CF	CF
150	6	40.6	89	55.6	122	81.6	180	126	276	176	386	CF	CF
200	8	59.6	131	86.6	191	130	285	198	435	CF	CF	Not Available	
250	10	98.6	217	132	290	213	468	251	551	CF	CF		
300	12	151	331	202	444	272	598	304	668	CF	CF		
400	16	335	736	385	846	575	1,264	412	905	CF	CF		
450	18	502	1,104	530	1,165	756	1,662	CF	CF	CF	CF		
500	20	CF	CF	CF	CF	CF	CF	CF	CF	CF	CF		
600	24	CF	CF	CF	CF	CF	CF	CF	CF	CF	CF		

CF = Consult factory

Daniel Series 1500 Turbine Flow Meter Selection Matrix

Device	T	XX	X	X	X	X	X	X	X	X	X	X	X	X	X	X	Tagging Format
Series 1500	T																Line Size / Pressure Rating / Flow Parameters
Line Size / Standard Flow Range																	1 Inch /ANSI / US Customary
1" DN25 (7-70 GPM, 10-100 BHP, 1.6-16 M ³ /H)	01																2 Inch /ANSI / Metric
1.5" DN40 (15-150 GPM, 21-214 BHP, 3.4-34 M ³ /H)	15																3 DN / PN / US Customary
2" DN50 (30-300 GPM, 43-429 BHP, 6.8-68 M ³ /H)	02																4 DN / PN / Metric
2.5" DN65 (40-400 GPM, 57-571 BHP, 9.1-91 M ³ /H)	25																Electrical Approvals
3" DN80 (70-700 GPM, 100-1000 BHP, 15.9-159 M ³ /H)	03																UL / cUL
4" DN100 (130-1295 GPM, 185-1850 BHP, 29.4-294 M ³ /H)	04																CE (Includes ATEX, PED or SEP and EMC), IECEx
6" DN150 (294-2940 GPM, 420-4200 BHP, 66.8-668 M ³ /H)	06																INMETRO
8" DN200 (595-5950 GPM, 850-8500 BHP, 135-1,351 M ³ /H)	08																Linearity
10" DN250 (840-8400 GPM, 1200-12000 BHP, 191-1,908 M ³ /H)	10																C 1"-2.5" (±0.25%), 3"-24" (±0.15%)
12" DN300 (1260-12600 GPM, 1800-18000 BHP, 286-2,862 M ³ /H)	12																D 1"-2.5" (±0.15%), 3"-24" (±0.10%)
16" DN400 (1960-19600 GPM, 2800-28000 BHP, 445-4,452 M ³ /H)	16																E 3"-24" (±0.07% with 5:1 Turndown)
18" DN450 (2800-28000 GPM, 4000-40000 BHP, 636-6,359 M ³ /H)	18																Display Mounting
20" DN500 (3,360-33,600 GPM, 4,800-48,000 BHP, 763-7,631 M ³ /H)	20																None
24" DN600 (4,200-42,000 GPM, 6,000-60,000 BHP, 954-9,539 M ³ /H)	24																Integral (-40°C to +60°C Only)
Pressure Rating / Flange Type (at 38°C)																	Display
150# ANSI, RF (Sizes 1" - 24", 285 psi MWP, 125-250 AARH)	A																None
300# ANSI, RF (Sizes 1" - 24", 740 psi MWP, 125-250 AARH)	B																Electronic Register
600# ANSI, RF (Sizes 1" - 24", 1,480 psi MWP, 125-250 AARH)	C																Materials of Construction
900# ANSI, RF (Sizes 1" - 24", 2,220 psi MWP, 125-250 AARH)	D																Body / Flange / Internals
1500# ANSI, RF (Sizes 1" - 2.5", 3,705 psi MWP, 125-250 AARH)	E																1 304 SS / 304 SS / 304 SS (1"-24")
600# ANSI, RTJ (Sizes 1" - 24", 1,480 psi MWP)	K																2 CS / CS / 304 SS (3"-24")
900# ANSI, RTJ (Sizes 1" - 24", 2,220 psi MWP)	M																4 316 SS / 316 SS / 316 SS (1"-24")
1500# ANSI, RTJ (Sizes 1" - 2.5", 3,705 psi MWP)	N																5 CS / CS / 316 SS (3"-24")
2500# ANSI, RTJ (Sizes 1" - 2.5", 6,170 psi MWP)	R																A 304 SS / 304 SS / 304 SS - NACE (1"-24")
1500# DANIEL, RTJ (Sizes 3" - 24", 3,705 psi MWP)	S																B CS / CS / 304 SS - NACE (3"-24")
2500# DANIEL, RTJ (Sizes 3" - 6", 6,170 psi MWP)	T																C 316 SS / 316 SS / 316 SS - NACE (1"-24")
DIN 2501 PN16, RF (Sizes 1" - 24", 16 BAR MWP, 125-250 AARH)	1																D CS / CS / 316 SS - NACE (3"-24")
DIN 2501 PN25, RF (Sizes 1" - 24", 25 BAR MWP, 125-250 AARH)	2																Flow Direction / Flow Conditioning
DIN 2501 PN40, RF (Sizes 1" - 24", 40 BAR MWP, 125-250 AARH)	3																A Horizontal, No Flow Conditioning Plate (1"-24")
DIN 2501 PN63, RTJ (Sizes 1" - 24", 63 BAR MWP)	4																B Vertical, No Flow Conditioning Plate (1"-8")
DIN 2501 PN100, RTJ (Sizes 1" - 24", 100 BAR MWP)	5																C Horizontal, Flow Conditioning Plate (Aluminum) (3"-8")
Design Style																	D Vertical, Flow Conditioning Plate (Aluminum) (3"-8")
Single 316 SS LME (Sizes 1" - 24")	L																E Horizontal, Bi-Directional, No Flow Conditioning Plate (1"-24")
Double 316 SS LMEs (Sizes 3" - 24")	M																Rotor Type
Meter Output / Temperature Range																	Blade-Type Rotor (1"-6")
Standard Temperature Options (-40°C to +60°C)																	A Uni-Directional
2 Pick-Offs Only (90° Out of Phase), LME	0																B Bi-Directional
2 Pick-Offs, LME w/ Dual Channel Preamplifier	1																F Teflon Coated, Uni-Directional
2 Pick-Offs, LME w/ Zero Crossing Preamplifier	2																G Teflon Coated, Bi-Directional
2 Pick-Offs, LME w/ Intrinsically Safe Preamplifier	3																Rim-Type Rotor (3"-24")
2 Pick-Offs, LME w/ Bi-Directional Preamplifier	4																C Uni-Directional
4 Pick-Offs Only (Each Pair 90° Out of Phase), 2 LMEs	5																D Bi-Directional
4 Pick-Offs, 2 LMEs each w/Dual Channel Preamplifiers	6																H Teflon Coated, Uni-Directional
4 Pick-Offs, 2 LMEs each w/Zero Crossing Preamplifiers	7																J Teflon Coated, Bi-Directional
4 Pick-Offs, 2 LMEs each w/Intrinsically Safe Preamplifiers	8																Light Product Rotor (3" - 12")
4 Pick-Offs, 2 LMEs each w/Bi-Directional Preamplifiers	9																M Uni-Directional
High Temperature Options (-40°C to +204°C)																	Metrology Approvals
2 HT Pick-Offs, LME w/2 Terminal Blocks	P																Unspecified
2 HT Pick-Offs, LME w/2 Terminal Blocks, 1 RME w/Dual Channel Preamplifier	Q																OIML (Sizes 3" - 16")
2 HT Pick-Offs, LME w/2 Terminal Blocks, 1 RME w/Zero Crossing Preamplifier	R																MID/OIML
2 HT Pick-Offs, LME w/2 Terminal Blocks, 1 RME w/Intrinsically Safe Preamplifier	S																
2 HT Pick-Offs, LME w/2 Terminal Blocks, 1 RME w/Bi-Directional Preamplifier	T																
4 HT Pick-Offs, (Each Pair 90° Out of Phase), 2 LMEs w/2 Terminal Blocks	U																
4 HT Pick-Offs, 2 LMEs Each w/2 Terminal Blocks, 1 RME w/Dual Channel Preamplifier	V																
4 HT Pick-Offs, 2 LMEs Each w/2 Terminal Blocks, 1 RME w/Zero Crossing Preamplifier	W																
4 HT Pick-Offs, 2 LMEs Each w/2 Terminal Blocks, 1 RME w/Intrinsically Safe Preamplifier	Y																
4 HT Pick-Offs, 2 LMEs Each w/2 Terminal Blocks, 1 RME w/Bi-Directional Preamplifier	Z																
4 HT Pick-Offs, 2 LMEs Each w/2 Terminal Blocks, 2 RMEs each w/Dual Channel Preamplifier	1																

This is for informational purposes only. Not every option is listed and some options are contingent on others. Please consult factory for assistance designing your optimal meter.

Emerson Process Management

Daniel Measurement and Control, Inc.
North America / Latin America:
Headquarters
USA - Houston, Texas
T +1.713.467.6000
USA Toll Free 1.888.FLOW.001

www.Daniel.com

Europe: Stirling, Scotland, UK
T +44.1786.433400
Middle East, Africa: Dubai, UAE
T +971.4.811.8100
Asia Pacific: Singapore
T +65.6777.8211

Scan with your smart
phone for more
information



©2015 Daniel Measurement and Control, Inc. All Rights Reserved. Unauthorized duplication in whole or in part is prohibited. Printed in the USA. DAN-LIQ-DS-1500TM-0115

Daniel Measurement and Control, Inc. (“Daniel”) is an Emerson Process Management business unit. The Daniel name and logo are trademarks of Daniel Industries, Inc. The Emerson logo is a trademark and service mark of Emerson Electric Co. All other trademarks are the property of their respective companies.

