

Daniel™ Series 1500 Liquid Turbine Meter

NPS 3 through 24



Safety and approval information

This Daniel product complies with all applicable European directives when properly installed in accordance with the instructions in this manual. Refer to the EU declaration of conformity for directives that apply to this product. The EU declaration of conformity, with all applicable European directives, and the complete ATEX Installation Drawings and Instructions are available on the internet at www.emerson.com or through your local Daniel support center.

Information affixed to equipment that complies with the Pressure Equipment Directive, can be found on the internet at <http://www.emerson.com>.

For hazardous installations in Europe, refer to standard EN 60079-14 if national standards do not apply.

Other information

Full product specifications can be found in the product data sheet. Troubleshooting information can be found in the user manual. Product data sheets and manuals are available from the Daniel web site at <http://www.emerson.com>.

Return policy

Follow Emerson procedures when returning equipment. These procedures ensure legal compliance with government transportation agencies and help provide a safe working environment for Emerson employees. Emerson will not accept your returned equipment if you fail to follow Emerson procedures. Return procedures and forms are available on our web support site at www.emerson.com, or by phoning the Emerson Customer Service department.

Emerson Flow customer service

Email:

- Worldwide: flow.support@emerson.com
- Asia-Pacific: APflow.support@emerson.com

Telephone:

North and South America		Europe and Middle East		Asia Pacific	
United States	800-522-6277	U.K.	0870 240 1978	Australia	800 158 727
Canada	+1 303-527-5200	The Netherlands	+31 (0) 704 136 666	New Zealand	099 128 804
Mexico	+41 (0) 41 7686 111	France	0800 917 901	India	800 440 1468
Argentina	+54 11 4837 7000	Germany	0800 182 5347	Pakistan	888 550 2682
Brazil	+55 15 3413 8000	Italy	8008 77334	China	+86 21 2892 9000
		Central & Eastern	+41 (0) 41 7686 111	Japan	+81 3 5769 6803
		Russia/CIS	+7 495 981 9811	South Korea	+82 2 3438 4600
		Egypt	0800 000 0015	Singapore	+65 6 777 8211
		Oman	800 70101	Thailand	001 800 441 6426
		Qatar	431 0044	Malaysia	800 814 008
		Kuwait	663 299 01		
		South Africa	800 991 390		
		Saudi Arabia	800 844 9564		
		UAE	800 0444 0684		

Contents

Part I	Plan	
Chapter 1	Introduction.....	7
	1.1 Purpose of this manual.....	7
	1.2 Hazard messages.....	7
	1.3 Personnel qualifications.....	7
	1.4 Warranty restrictions.....	9
	1.5 Assistance.....	9
	1.6 Description of the Series 1500 Liquid Turbine Meter (LTM).....	10
	1.7 Agency certifications for the Series 1500 LTM.....	37
Chapter 2	Operating conditions and specifications.....	39
	2.1 Operating conditions for the liquid turbine meter.....	39
	2.2 Specifications for the LTM	44
Chapter 3	Turbine meter handling.....	53
	3.1 Receive the turbine meter.....	53
	3.2 Store the turbine meter.....	53
Chapter 4	Prepare the turbine meter for use.....	55
	4.1 Lifting conditions.....	55
	4.2 Lifting requirements for personnel.....	56
	4.3 Configuration of the turbine meter.....	59
Part II	Install	
Chapter 5	Installation prerequisites.....	69
	5.1 Pre-start checks.....	69
	5.2 Torque information.....	69
	5.3 Tools required for LME disassembly/assembly.....	69
Chapter 6	Installation procedure.....	71
	6.1 Cathodic protection.....	71
	6.2 Mechanical components assembly.....	71
	6.3 Assemble the electronic components.....	72
Chapter 7	Testing.....	75
	7.1 Test the turbine meter.....	75
Part III	Operate	

Chapter 8	Operation parameters.....	79
	8.1 Operation overview.....	79
	8.2 Turbine meter normal operation.....	79
	8.3 Back pressure calculation for the LTM.....	79
	8.4 LME remote operation.....	80
Part IV	Maintain	
Chapter 9	Planned maintenance.....	83
	9.1 Maintenance considerations.....	83
	9.2 Tools required for mechanical components.....	83
	9.3 Prepare for mechanical disassembly.....	84
	9.4 Mechanical assembly.....	89
	9.5 Electronics enclosure disassembly.....	93
	9.6 Electronics enclosure assembly.....	94
	9.7 Replace the preamplifier.....	95
	9.8 Planned maintenance tasks.....	96
Chapter 10	Corrective maintenance.....	97
	10.1 Turbine meter troubleshooting.....	97
	10.2 Verify the return to operational condition.....	97
Chapter 11	Spare parts.....	99
	11.1 Recommended spare parts.....	99
Chapter 12	Decommission the turbine meter.....	101
	12.1 Shut down the turbine meter.....	101
	12.2 Turbine meter disassembly/assembly.....	101
	12.3 Shipment of the meter.....	102

Part I

Plan

1 Introduction

1.1 Purpose of this manual

Emerson Daniel designed this manual to guide owners and personnel in the installation, operation and maintenance of the Daniel™ Series 1500 Liquid Turbine Meter Manual, 3-9008-515. It is imperative that product owners and operation personnel read and follow the information contained in this manual to ensure that the turbine meter is installed correctly and is operating according to the design, certifications and safety considerations.

1.2 Hazard messages

This document uses the following criteria for hazard messages based on ANSI standards Z535.6-2011 (R2017).

 **DANGER**

Serious injury or death will occur if a hazardous situation is not avoided.

 **WARNING**

Serious injury or death could occur if a hazardous situation is not avoided.

 **CAUTION**

Minor or moderate injury will or could occur if a hazardous situation is not avoided.

NOTICE

Data loss, property damage, hardware damage, or software damage can occur if a situation is not avoided. There is no credible risk of physical injury.

Physical access

NOTICE

Unauthorized personnel can potentially cause significant damage and/or misconfiguration of end users' equipment. Protect against all intentional or unintentional unauthorized use. Physical security is an important part of any security program and fundamental to protecting your system. Restrict physical access to protect users' assets. This is true for all systems used within the facility.

1.3 Personnel qualifications

Read and follow all instructions, dangers, warnings, and cautions to avoid personal injury or property damage during system operation. Emerson is not responsible for damage or injury resulting from unsafe use of products, lack of maintenance, incorrect installation of equipment or system operation. If in doubt about any applications and safety precautions described in this document, contact Emerson.

Inform and train all personnel in the proper installation, operation, and maintenance of this product. To ensure safe and proper performance, only informed and trained personnel should install, operate, repair and maintain this product. For further questions about training requirements, contact your local Emerson representative.

Operations risk assessment must be used and followed in conjunction with this document when performing all online retrieval operations.

Ensure that all end user and installation specific safety requirements are read, understood and adhered to.

Ensure that any operator that is conducting work on the equipment, is following end user guidelines on the use of protective equipment including, but not limited to:

- Safety helmet or hard hat
- Steel-toed shoes
- Safety glasses
- Working gloves (suitable for mechanical operations)
- Chemical resistant latex gloves or the equivalent
- Long-sleeved, fire-retardant shirt and fire-retardant trousers or full-length fire retardant coveralls

Additional PPE may be required depending on facility requirements and MSDS requirements, if applicable. Failure to comply may result in personnel injury.



WARNING

RISK TO PERSONNEL AND EQUIPMENT

Failure to follow the installation, operation or maintenance instructions for a Daniel product could lead to serious injury or death from explosion or exposure to dangerous substances. To reduce the risk:

- Comply with all information on the product, in this manual, and in any local and national codes that apply to this product.
- Do not allow untrained personnel to work with this product.
- Use Daniel parts and work procedures specified in this manual.

NOTICE

Observe all precautionary signs posted on the equipment to avoid serious injury.



WARNING

RISK TO PERSONNEL AND EQUIPMENT

Operation of this product on pressurized lines may potentially imply operational risk for personnel and equipment from the potential escape of hot gas or liquid, which could result in serious injury.

Observe all precautionary signs on the equipment.

 **WARNING**

RISK TO PERSONNEL AND EQUIPMENT

The operation of the Daniel product involves heavy equipment handling. Observe the following guidelines to avoid potentially serious injury:

- Be aware of your limitations and ask for assistance if needed.
- Do not attempt to lift weight beyond your capacity.
- Lift with your legs, not your back.

Note

Mechanical lifting tools may also be used in some locations to reduce risk.

NOTICE

Attending the training course for this product is not considered sufficient for operating the tool on pressurized lines. Emerson requires a two-man crew with formal training. Additionally, at least one of the operators must have a record of extensive field experience and be certified for this work.

Emerson assumes no responsibility for incidents, or consequences of incidents, occurring as a result of the use of this product by others than Emerson or its designated personnel, and have no liability whatsoever for any such work.

Consult Emerson for more details on both training and certification.

1.4 Warranty restrictions

Visually inspect all components for shipping damage. If shipping damage is found, notify the carrier at once. Shipping damage is not covered by the warranty. The carrier is responsible for all repair and replacement costs resulting from shipment damage.

1.5 Assistance

The Emerson Global Service Center is organized through a network of service centers worldwide, and supports all service requirements or technical queries. For the Product Support Help Desk, go to: <http://www.emerson.com> or contact your nearest Emerson service provider.

1.6 Description of the Series 1500 Liquid Turbine Meter (LTM)

1.6.1 General features of the turbine meter

The Daniel Series 1500 Liquid Turbine Meter (LTM) is a volumetric flow metering and transmitting device used for accurate measurement of crude oil hydrocarbons and other related process fluids. The design allows high operational flow rates, extended flow ranges and sustained performance capability. This meter is specifically designed for pipeline service where a vital characteristic is repeatability.

The turbine meter is designed for use within the guidelines of *API Manual of Petroleum Measurement Standards (MPMS)*, Chapter 5.3 and test procedures of API MPMS, Chapter 4 (Prover systems).

The meter consists of two main parts: Local Mounted Enclosure (LME) assembly and the meter body housing assembly. For certain functions, the meter will have a Remote Mounted Enclosure (RME), another version of the LME.

The LME is an explosion-proof, weather-resistant housing for dual pickoffs, as well as an encapsulated preamplifier. It also serves as the mechanical mounting connection necessary for local and remote accessories.

Note

Daniel offers electronic enclosures with different housing materials and electronic configurations.

Local Mounted Enclosure (LME)

The LME consists of an electrical enclosure and a solid cover made of stainless steel. This configuration contains a mounting bracket and a preamplifier which works with two standard pickoff coils mounted into the meter housing.

The electrical enclosure contains an external and an internal grounding lug. The two enclosure openings are plugged with stainless steel plugs. Refer to [Operating conditions and specifications](#) for more specifications.

LME - High temperature

The LME - High temperature consists of an electrical enclosure and a solid cover both made of stainless steel. This configuration contains one mounting bracket and two high temperature terminal blocks which are the connections between the high temperature pickoff coils and the flex cable.

Important

The customer provides and installs a flex cable.

The flex cable is the connection between the preamplifier that is assembled into a Remote Mounted Enclosure (RME), not more than 6 meters from the center of the meter housing to the center of the RME.

The electrical enclosure contains an external and an internal grounding lug. The two enclosure openings are plugged. Refer to [Operating conditions and specifications](#).

Remote Mounted Enclosure (RME)

The RME is an electric transmitting device used primarily in the petroleum industry for remote installation of liquid turbine meter electronics. The RME is specifically designed for high temperature applications.

The turbine meter is ideal for applications requiring high frequency resolution. Applications may include electronic registers or flow computers.

1.6.2 Operation overview of the turbine meter

Metering systems combine turbine meters and electronic instrumentation to measure volumetric total flow and/or flow rate. Metering systems are used to provide measurement information in fluid transport, petroleum and chemical processing, custody transfer of liquids, blending systems, in product batching and in field or plant operations.

- Each turbine meter is comprised of a cylindrical housing that contains a precise turbine rotor assembly. The magnetic pickoffs are mounted in a boss on the turbine meter body.
- As fluid passes through the turbine meter, it causes the rotor to revolve with an angular velocity proportional to flow.
- The rotor blades or rim buttons passing through the magnetic field of the pickoff generate a pulsing voltage in the coil of the pickoff assembly. Each voltage pulse represents a discrete volume. The total number of pulses collected over a period of time represents the total volume metered.
- The sinusoidal signal from each pickoff has a low amplitude and is not normally relied upon for transmission distances over 6 meters (20 feet). The signal must, therefore, be amplified. This is achieved with a preamplifier contained within the LME that is mounted on the turbine meter.
- These pulse signals are typically transmitted to control room instrumentation, such as flow computers, and may also be required to transmit to prover computers which calculate, display, transmit, control or record the flow sensed by the rotor. The results may be displayed as pulse-counts or standard engineering units, such as gallons, liters, barrels, etc.
- All Daniel Series 1500 Liquid Turbine Meters have, as standard, the LME which is fitted with two pickoffs and a dual channel preamplifier.
- The pickoff mountings are oriented so that the outputs from the pickups are 90° electrically out of phase. The turbine meter may be supplied with two LMEs, offering up to four pulse outputs. Alternate pairs across the two LMEs are also 90° electrically out of phase.
- Each turbine meter is precisely flow calibrated before shipment.

1.6.3 Parts lists for the Series 1500 LTM, Nominal Pipe Size (NPS) 3-24

This section includes the necessary parts required to assemble a standard unit described in this manual.

Configurations for [LME assembly - Standard enclosure](#), [LME assembly - High temperature](#), [RME assembly - Pipe mount](#) and [RME assembly - Wall mount](#) are shown below.

LME assembly - Standard enclosure

Figure 1-1: Part identification for a standard enclosure

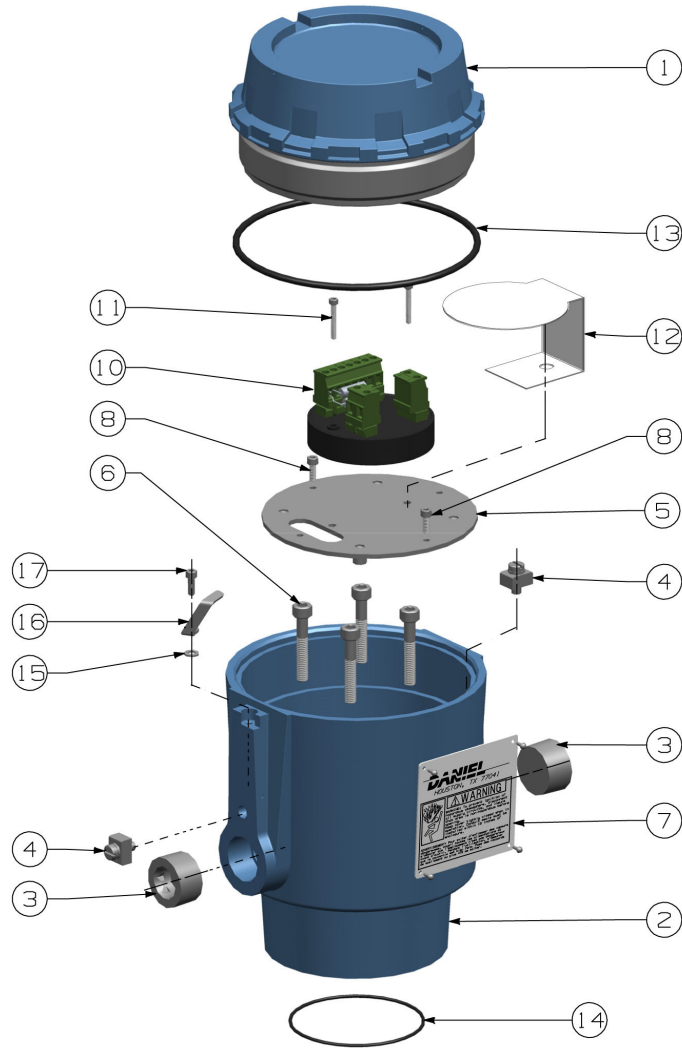

Table 1-1: Part description for a standard enclosure

Item number	Description	Part number	Quantity required
1 ⁽¹⁾	End cap solid	1-360-00-025	1
2 ⁽¹⁾	Electronics enclosure	899-10-110-60	1
3	Plug pipe hex socket	154717-019	2
4	Grounding clamp	B18934-004	2
5	Mounting bracket	899-10-230-50	1
6 ⁽²⁾	Socket head screw	899-10-230-52	4
7	Warning tag-Hazard	899-00-228-04	1
8	Socket head screw	899-10-230-61	2
10 ⁽³⁾	2818 Dual channel preamplifier	1-504-05-550	1
11	Socket head screw	899-10-230-65	2
12 ⁽³⁾	Wiring diagram for 2818 Dual channel preamplifier	899-10-228-07	1
13	O-ring NBR	2-4-9163-245	1
14	O-ring FKM	1500093-022	1
15	Washer plastic	1-562-01-827	1
16	Clamp cover	1-504-90-165	1
17	Socket head screw	1-555-27-001	1

(1) Enclosure housing and end cap material: stainless steel.

(2) Screw length varies on LTM sizes. The screws are not included in the part number package.

(3) 2818 Dual channel shown. For other preamplifier options refer to [Interface parameters](#).

NOTICE

The joint between the LME cover and housing is a threaded joint. The joint between the LME housing and Sensor housing is a spigot joint with a minimum axial length of 26.16 mm (1.030 in), radial length of 3.18 mm (0.125 in), and a clearance of 0.07 mm (0.0028 in).

LME assembly - Internal Totalizer

Figure 1-2: Part identification for the LME with Internal Totalizer

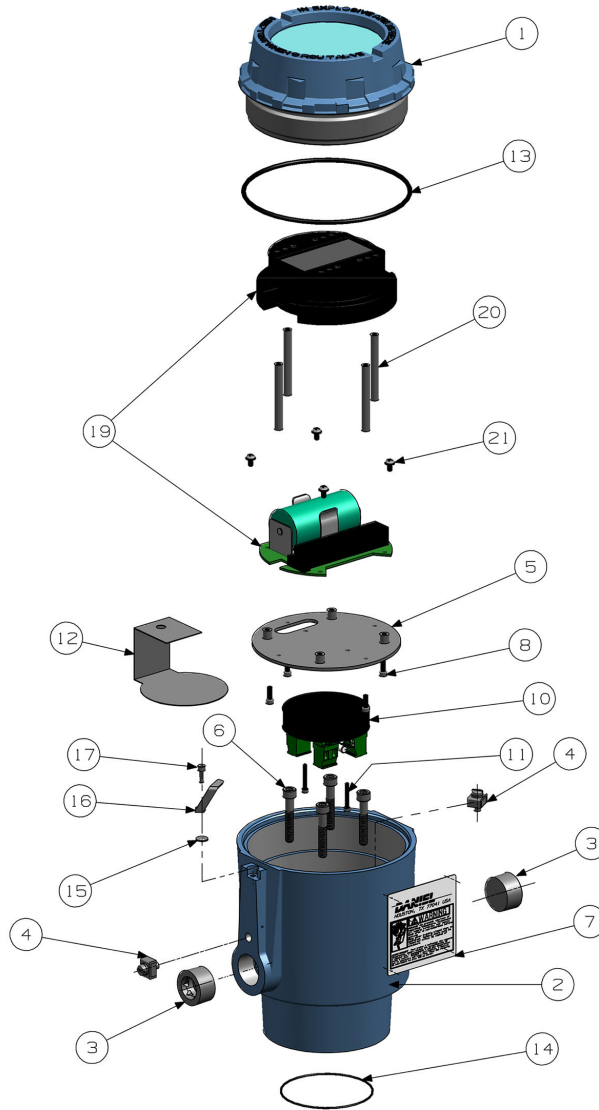

Table 1-2: Part description for the LME with Internal Totalizer

Item number	Description	Part number	Quantity required
1 ⁽¹⁾	Cover (SS/ALUM)	899-10-230-60/70	1
2	Electronics enclosure (SS/ALUM)	899-10-110-60/70	1
3	Plug pipe hex socket	154717-019	2
4	Grounding cap	B18934-004	2
5	Mounting bracket	899-10-230-50	1
6 ⁽²⁾	Socket head screw	899-10-230-52	4
7	Warning tag-Hazard	899-00-328-04	1
8	Socket head screw	899-10-230-61	4
10	2818 Dual channel preamplifier	1-504-05-550	1
11	Socket head screw	899-10-230-65	2
12 ⁽³⁾	Wiring diagram for 2818 Dual channel preamplifier	899-10-230-69	1
13	O-ring NBR	2-4-9163-245	1
14	O-ring FKM	1500093-022	1
15	Washer plastic	1-562-01-827	1
16	Clamp cover	1-504-90-165	1
17	Socket head screw	1-555-27-001	1
19	Display and terminal block	899-10-230-30/32	1
20	Female standoff	899-10-230-63	4
21	Machine screw	899-10-230-64	4

(1) Enclosure housing and cap material: aluminum. Optional: stainless steel.

(2) Screw length varies on LTM sizes. The screws are not included within the part number package.

(3) 2818 Dual channel shown. For other preamplifier options, refer to [Interface parameters](#).

NOTICE

The joint between the LME cover and housing is a threaded joint. The joint between the LME housing and sensor housing is a cylindrical joint which has an axial length of 25.4 mm (1 in) and a clearance of 0.038 mm (0.0015 in).

LME assembly - with Two Preamps

Figure 1-3: Part identification Two preamps configuration

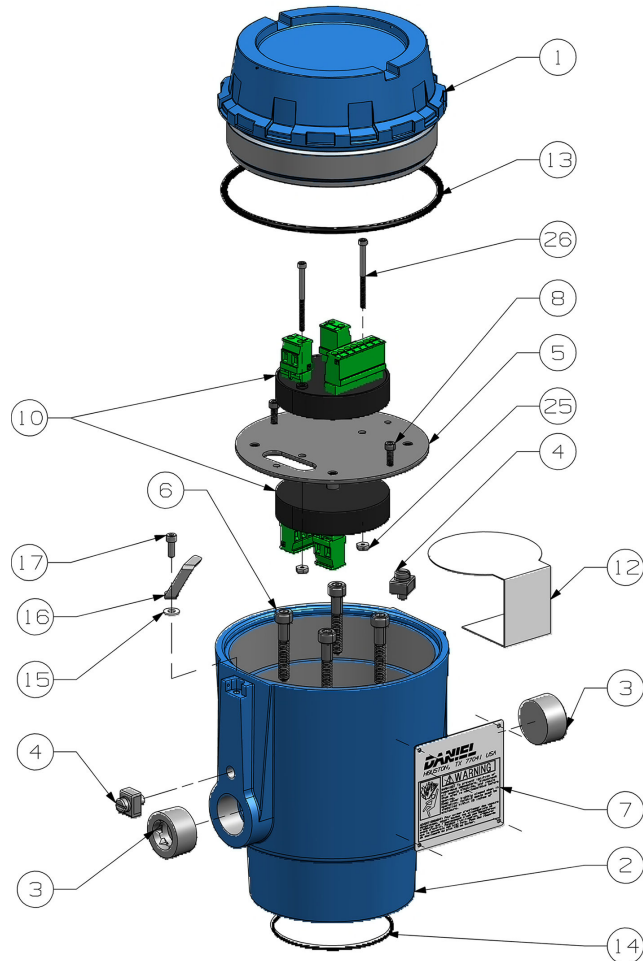

Table 1-3: Part description for the LME with Two Preamps configuration

Item number	Description	Part number	Quantity required
1 ⁽¹⁾	Cover (SS/ALUM)	899-10-230-60/70	1
2 ⁽¹⁾	Electronics enclosure (SS/ALUM)	899-10-230-60/70	1
3	Plug pipe hex socket	154717-019	2
4	Grounding cap	B18934-004	2
5	Mounting bracket	899-10-230-50	1
6 ⁽²⁾	Socket head screw	899-10-230-52	4
7	Warning tag-Hazard	899-00-228-04	1
8	Socket head screw	899-10-230-61	4
10 ⁽³⁾	2818 Dual channel preamplifier	1-504-05-550	2
12	Wiring diagram for 2818 Dual channel preamplifier	899-10-230-69	1
13	O-ring NBR	2-4-9163-245	1
14	O-ring FKM	1500093-022	1
15	Washer plastic	1-562-01-827	1
16	Clamp cover	1-504-90-165	1
17	Socket head screw	1-555-27-001	1
25	Nut	899-10-230-77	1
26	Socket head screw	899-10-230-78	2

(1) Enclosure housing and cap material: aluminum. Optional: stainless steel.

(2) Screw length varies on LTM sizes. The screws are not included within the part number package.

(3) 2818 Dual channel shown. For other preamplifier options, refer to [Interface parameters](#).

NOTICE

The joint between the LME cover and housing is a threaded joint. The joint between the LME housing and sensor housing is a cylindrical joint which has an axial length of 25.4 mm (1 in) and a clearance of 0.038 mm (0.0015 in).

LME assembly - High temperature

Figure 1-4: Part identification for a high temperature enclosure

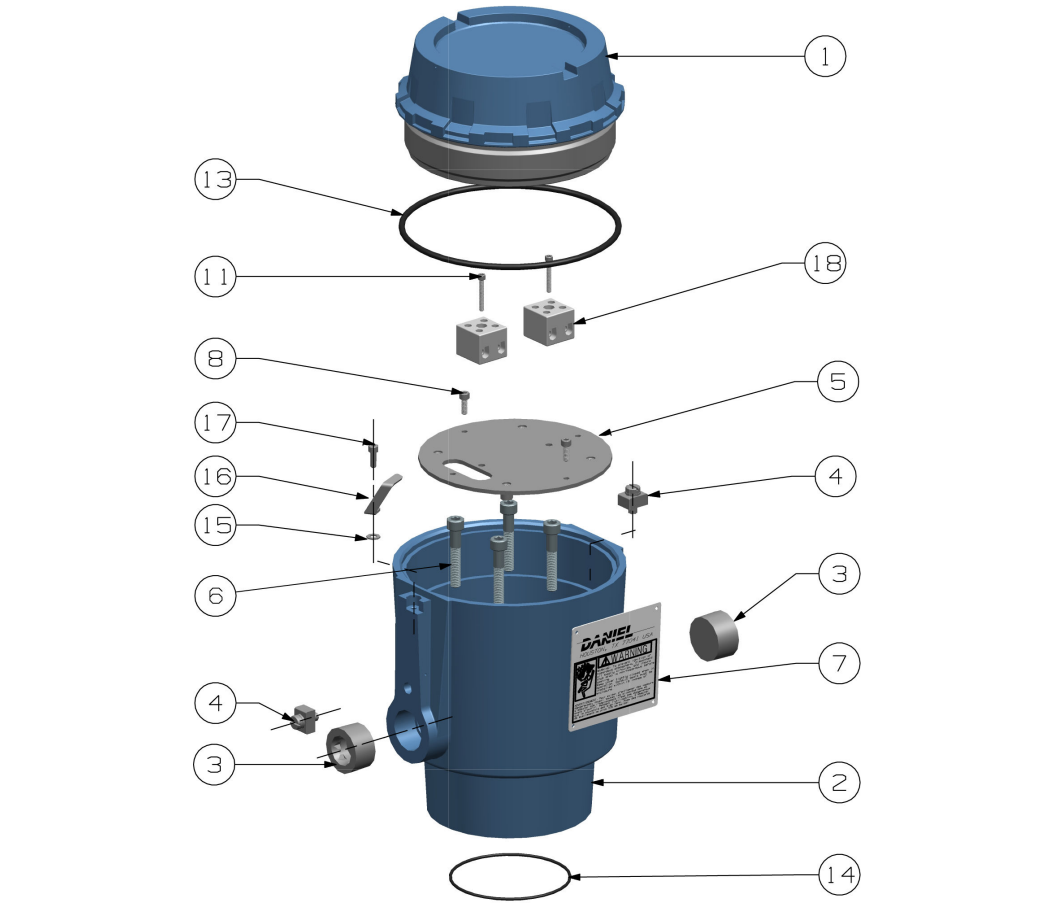

Table 1-4: Part description for a high temperature enclosure

Item number	Description	Part number	Quantity required
1 ⁽¹⁾	End cap solid	1-360-00-25	1
2 ⁽²⁾	Electronics enclosure	899-10-110-60	1
3	Plug pipe hex socket	154717-019	2
4	Grounding clamp	B18934-004	2
5	Mounting bracket	899-10-230-50	1
6 ⁽³⁾	Socket head screw	899-10-230-52	4
7	Warning tag-Hazard	899-00-225-04	1
8	Socket head screw	899-10-230-61	2
11	Socket head screw	899-10-230-65	2
13	O-ring FKM	2-4-9163-245	1
14	O-ring FKM	1500093-022	1
15	Washer plastic	1-562-01-827	1
16	Clamp cover	1-504-90-165	1
17	Socket head screw	1-555-27-001	1
18	Terminal block	1505065	2

(1) Enclosure housing and end cap material: stainless steel.

(2) ⁽¹⁾

(3) Screw length varies on LTM sizes. The screws are not included in the part number package.

NOTICE

The joint between the LME cover and housing is a threaded joint. The joint between the LME housing and Sensor housing is a spigot joint with a minimum axial length of 26.16 mm (1.030 in), radial length of 3.18 mm (0.125 in), and a clearance of 0.07 mm (0.0028 in).

RME assembly - Pipe mount

Figure 1-5: Part identification for an RME assembly - Pipe mount

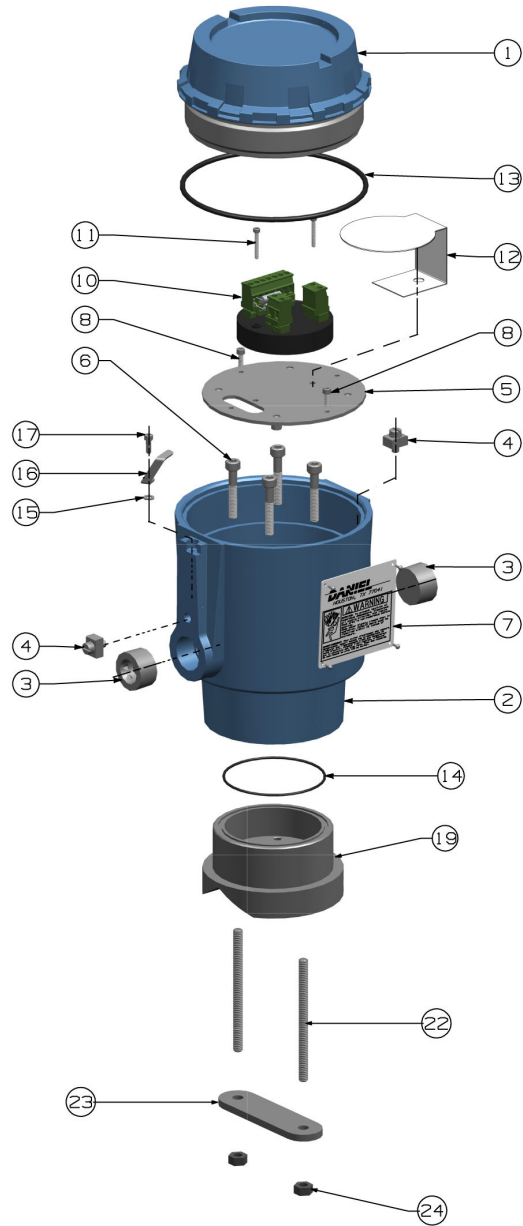

Table 1-5: Part description for an RME assembly - Pipe mount

Item number	Description	Part number	Quantity required
1 ⁽¹⁾	End cap solid	1-360-00-025	1
2 ⁽¹⁾	Electronics enclosure	899-10-110-60	1
3	Plug pipe hex socket	154717-019	2
4	Grounding clamp	B18934-004	2
5	Mounting bracket	899-10-230-50	1
6 ⁽²⁾	Socket head screw	899-10-230-52	4
7	Warning tag-Hazard	899-00-228-04	1
8	Socket head screw	899-10-230-61	2
10 ⁽³⁾	2818 Dual channel preamplifier	1-504-05-550	1
11	Socket head screw	899-10-230-65	2
12 ⁽³⁾	Wiring diagram for 2818 Dual channel preamplifier	899-10-228-07	1
13	O-ring NBR	2-4-9163-245	1
14	O-ring FKM	1500093-022	1
15	Washer plastic	1-562-01-827	1
16	Clamp cover	1-504-90-165	1
17	Socket head screw	1-555-27-001	1
19	RME base	799-10-457-60M	1
22	Pipe mount studs	799-00-453-00	2
23	Pipe mount plate	799-00-454-00	1
24	Pipe mount nuts	151544	2

(1) Enclosure housing and end cap material: stainless steel.

(2) Screw length varies on LTM sizes. The screws are not included in the part number package.

(3) 2818 Dual channel shown. For other preamplifier options refer to [Interface parameters](#).

NOTICE

The joint between the RME cover and housing is a threaded joint. The joint between the RME housing and Sensor housing is a spigot joint with a minimum axial length of 26.16 mm (1.030 in), radial length of 3.18 mm (0.125 in), and a clearance of 0.07 mm (0.0028 in).

RME assembly - Wall mount

Figure 1-6: Part identification for an RME assembly - Wall mount

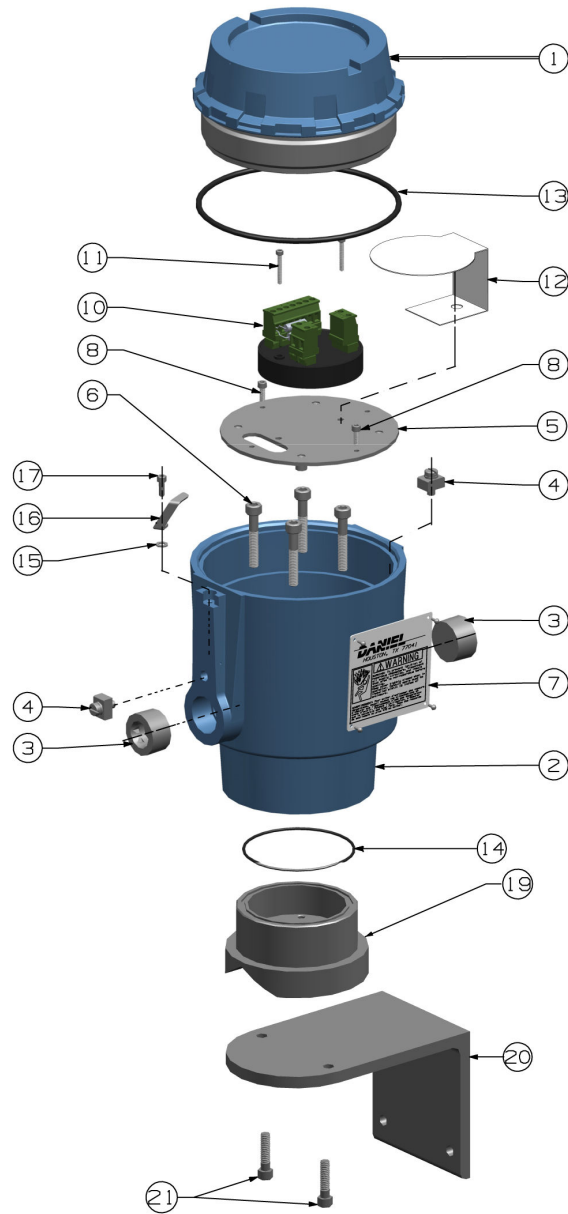

Table 1-6: Part description for an RME assembly - Wall mount

Item number	Description	Part number	Quantity required
1 ⁽¹⁾	End cap solid	1-360-00-025	1
2 ⁽¹⁾	Electronics enclosure	899-10-110-60	1
3	Plug pipe hex socket	154717-019	2
4	Grounding clamp	B18934-004	2
5	Mounting bracket	899-10-230-50	1
6 ⁽²⁾	Socket head screw	899-10-230-52	4
7	Warning tag-Hazard	899-00-228-04	1
8	Socket head screw	899-10-230-61	2
10 ⁽³⁾	2818 Dual channel preamplifier	1-504-05-550	1
11	Socket head screw	899-10-230-65	2
12 ⁽³⁾	Wiring diagram for 2818 Dual channel preamplifier	899-10-228-07	1
13	O-ring NBR	2-4-9163-245	1
14	O-ring FKM	1500093-022	1
15	Washer plastic	1-562-01-827	1
16	Clamp cover	1-504-90-165	1
17	Socket head screw	1-555-27-001	1
19	RME base	799-10-457-60M	1
20	Wall mount bracket	799-00-456-00	1
21	Wall mount screws	151497M	2

- (1) Enclosure housing and end cap material: stainless steel.
 (2) Screw length varies on LTM sizes. The screws are not included in the part number package.
 (3) 2818 Dual channel shown. For other preamplifier options refer to [Interface parameters](#).

NOTICE

The joint between the RME cover and housing is a threaded joint. The joint between the RME housing and Sensor housing is a spigot joint with a minimum axial length of 26.16 mm (1.030 in), radial length of 3.18 mm (0.125 in), and a clearance of 0.07 mm (0.0028 in).

Meter housing internal components - NPS 3 through 8 - Unidirectional

The figure below identifies and describes the NPS 3 through 8 unidirectional meter housing components.

Figure 1-7: Part identification for an NPS 3 through 8 unidirectional (blade or rimmed) LTM

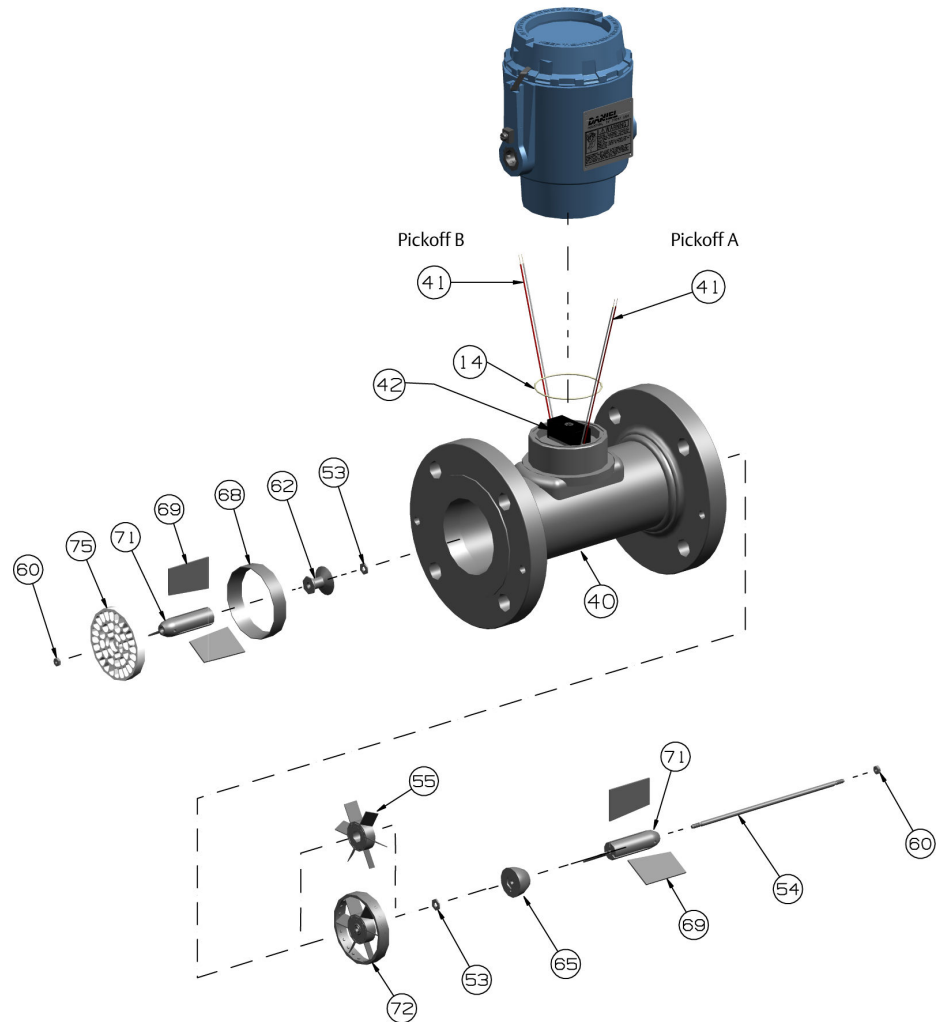

Table 1-7: Part description for an NPS 3 unidirectional LTM

Item number	Description	Part number for material 304 SS	Part number for material 316 SS	Quantity required
14	O-ring	1500093-022	1500093-022	1
40	Meter housing	Consult factory	Consult factory	1
41	Pickoff	899-00-201-00	899-00-201-00	2
42	Anti-rotation bracket clamp	899-10-230-66	899-10-230-66	1
53	Thrust washer	1-504-05-114	1-504-05-114	2
54	Shaft	1-504-05-622	1-504-05-622	1
	Shaft for FCP	1-504-05-623	1-504-05-623	1
55	Bladed rotor	1-307-11-235	1-307-11-236	1
60	Nut	1-561-76-192	1-561-76-192	2
62	Upstream cone-rimmed	1-307-10-435	1-307-10-439	1
	Upstream cone-bladed	1-307-10-437	1-307-10-438	1
65	Downstream cone	1-307-10-535	1-307-10-536	1
68	Housing insert	1-307-03-000	1-307-03-020	1
69	Hanger blades	1-307-10-735	1-307-10-736	6
71	Hanger hub	1-307-10-635	1-307-10-636	2
72	Rimmed rotor	1-307-11-237	1-307-11-238	1
75	Flow conditioning plate (FCP) (optional)	1-307-01-171	1-307-01-171	1

Table 1-8: Part description for an NPS 4 unidirectional LTM

Item number	Description	Part number for material 304 SS	Part number for material 316 SS	Quantity required
14	O-ring	1500093-022	1500093-022	1
40	Meter housing	Consult factory	Consult factory	1
41	Pickoff	899-00-201-00	899-00-201-00	2
42	Anti-rotation bracket clamp	899-10-230-66	899-10-230-66	1
53	Thrust washer	1-504-05-115	1-504-05-115	2
54	Shaft	1-504-05-627	1-504-05-627	1
	Shaft for FCP	1-504-05-628	1-504-05-628	1
55	Bladed rotor	1-307-11-300	1-307-11-301	1
60	Nut	1-561-76-155	1-561-76-155	2
62	Upstream cone-rimmed	1-307-10-440	1-307-10-444	1
	Upstream cone-bladed	1-307-10-442	1-307-10-443	1
65	Downstream cone	1-307-10-540	1-307-10-541	1

Table 1-8: Part description for an NPS 4 unidirectional LTM (continued)

Item number	Description	Part number for material 304 SS	Part number for material 316 SS	Quantity required
68	Housing insert	1-307-03-001	1-307-03-021	1
69	Hanger blades	1-307-10-740	1-307-10-741	6
71	Hanger hub	1-307-10-640	1-307-10-641	2
72	Rimmed rotor	1-307-11-302	1-307-11-303	1
75	Flow conditioning plate (FCP) (optional)	1-307-01-071	1-307-01-071	1

Table 1-9: Part description for an NPS 6 unidirectional LTM

Item number	Description	Part number for material 304 SS	Part number for material 316 SS	Quantity required
14	O-ring	1500093-022	1500093-022	1
40	Meter housing	Consult factory	Consult factory	1
41	Pickoff	899-00-201-00	899-00-201-00	2
42	Anti-rotation bracket clamp	899-10-230-66	899-10-230-66	1
53	Thrust washer	1-504-05-117	1-504-05-117	2
54	Shaft	1-504-05-632	1-504-05-632	1
	Shaft for FCP	1-504-05-633	1-504-05-633	1
55	Bladed rotor	1-307-11-400	1-307-11-401	1
60	Nut	1-561-76-163	1-561-76-163	2
62	Upstream cone-rimmed	1-307-10-445	1-307-10-446	1
	Upstream cone-bladed	1-307-10-447	1-307-10-448	1
65	Downstream cone	1-307-10-545	1-307-10-546	1
68	Housing insert	1-307-03-003	1-307-03-023	1
69	Hanger blades	1-307-10-745	1-307-10-746	6
71	Hanger hub	1-307-10-645	1-307-10-646	2
72	Rimmed rotor	1-307-11-402	1-307-11-403	1
75	Flow conditioning plate (FCP) (optional)	1-307-01-085	1-307-01-085	1

Table 1-10: Part description for an NPS 8 unidirectional LTM

Item number	Description	Part number for material 304 SS	Part number for material 316 SS	Quantity required
14	O-ring	15000093-022	15000093-022	1
40	Meter housing	Consult factory	Consult factory	1
41	Pickoff	899-00-201-00	899-00-201-00	2

Table 1-10: Part description for an NPS 8 unidirectional LTM (continued)

Item number	Description	Part number for material 304 SS	Part number for material 316 SS	Quantity required
42	Anti-rotation bracket clamp	899-10-230-66	899-10-230-66	1
53	Thrust washer	1-504-05-118	1-504-05-118	2
54	Shaft	1-504-05-637	1-504-05-637	1
60	Nut	1-561-76-171	1-561-76-171	2
62	Upstream cone-rimmed	1-307-10-450	1-307-10-451	1
65	Downstream cone	1-307-10-550	1-307-10-551	1
68	Housing insert	1-307-03-004	1-307-03-024	1
69	Hanger blades	1-307-10-750	1-307-10-751	6
71	Hanger hub	1-307-10-650	1-307-10-651	2
72	Rimmed rotor	1-307-11-404	1-307-11-405	1

Meter housing internal components - NPS 10 through 24 - Unidirectional

The figure below identifies and describes the NPS 10 through 24 unidirectional meter housing components.

Figure 1-8: Part identification for an NPS 10 through 24 unidirectional (rimmed) LTM

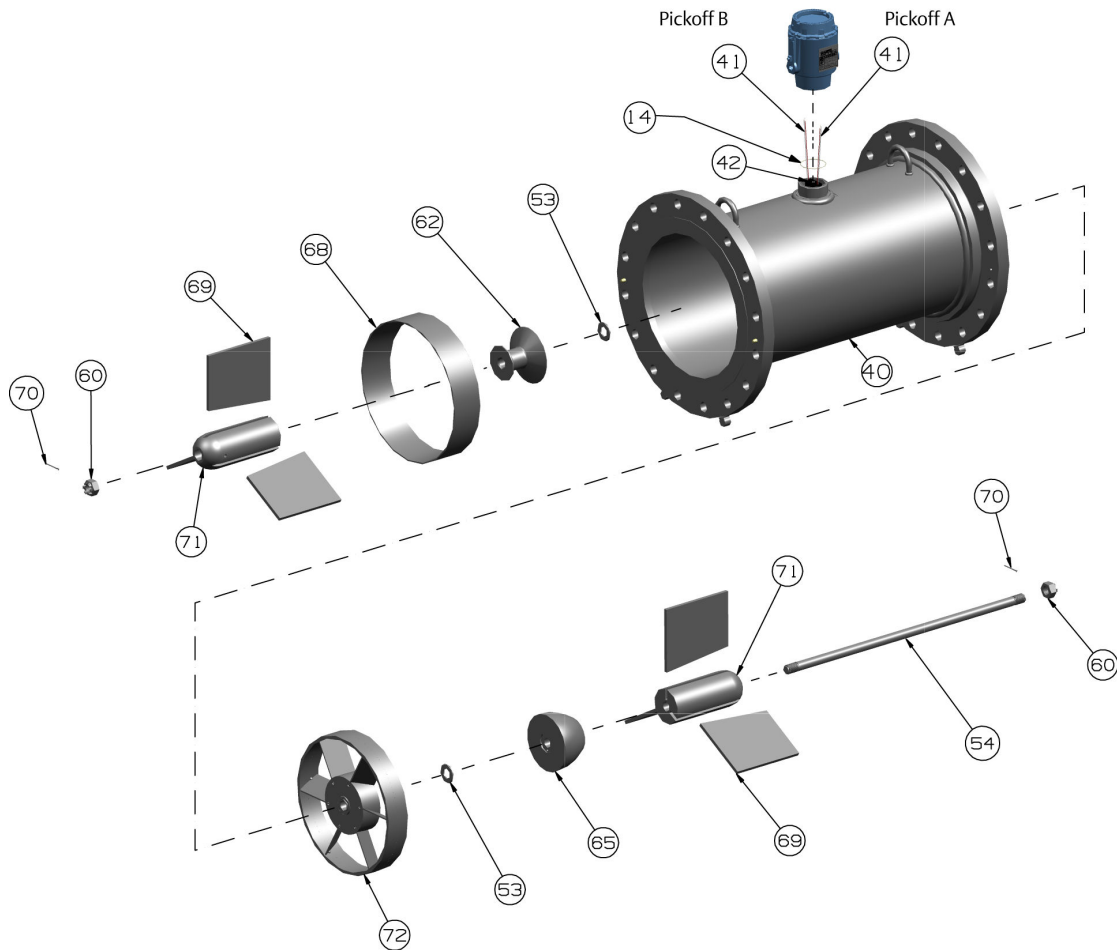

Table 1-11: Part description for an NPS 10 unidirectional LTM

Item number	Description	Part number for material 304 SS	Part number for material 316 SS	Quantity required
14	O-ring	1500093-022	1500093-022	1
40	Meter housing	Consult factory	Consult factory	1
41	Pickoff	899-00-201-00	899-00-201-00	2
42	Anti-rotation bracket clamp	899-10-230-66	899-10-230-66	1
53	Thrust washer	1-504-05-119	1-504-05-119	2
54	Shaft	1-504-05-642	1-504-05-642	1
60	Nut	1-561-76-183	1-561-76-183	2
62	Upstream cone	1-307-10-455	1-307-10-456	1
65	Downstream cone	1-307-10-555	1-307-10-556	1
68	Housing insert	1-307-03-005	1-307-03-025	1
69	Hanger blades	1-307-10-755	1-307-10-756	6
71	Hanger hub	1-307-10-655	1-307-10-656	2
72	Rotor assembly	1-307-11-406	1-307-11-407	1

Table 1-12: Part description for an NPS 12 unidirectional LTM

Item number	Description	Part number for material 304 SS	Part number for material 316 SS	Quantity required
14	O-ring	1500093-022	1500093-022	1
40	Meter housing	Consult factory	Consult factory	1
41	Pickoff	899-00-201-00	899-00-201-00	2
42	Anti-rotation bracket clamp	899-10-230-66	899-10-230-66	1
53	Thrust washer	1-504-05-120	1-504-05-120	2
54	Shaft	1-504-05-647	1-504-05-647	1
60	Nut	1-561-76-200	1-561-76-200	2
62	Upstream cone	1-307-10-460	1-307-10-461	1
65	Downstream cone	1-307-10-560	1-307-10-561	1
68	Housing insert	1-307-03-006	1-307-03-007	1
69	Hanger blades	1-307-10-760	1-307-10-761	6
71	Hanger hub	1-307-10-660	1-307-10-661	2
72	Rotor assembly	1-307-11-656	1-307-11-655	1

Table 1-13: Part description for an NPS 16 unidirectional LTM

Item number	Description	Part number for material 304 SS	Part number for material 316 SS	Quantity required
14	O-ring	1500093-022	1500093-022	1
40	Meter housing	Consult factory	Consult factory	1
41	Pickoff	899-00-201-00	899-00-201-00	2
42	Anti-rotation bracket clamp	899-10-230-66	899-10-230-66	1
53	Thrust washer	1-504-05-122	1-504-05-122	2
54	Shaft	1-504-05-652	1-504-05-652	1
60	Nut	1-561-76-083	1-561-76-083	2
62	Upstream cone	1-307-10-465	1-307-10-466	1
65	Downstream cone	1-307-10-565	1-307-10-566	1
68	Housing insert	1-307-03-008	1-307-03-018	1
69	Hanger blades	1-307-10-765	1-307-10-766	6
70	Cotter pin	1-562-05-639	1-562-05-639	2
71	Hanger hub	1-307-10-665	1-307-10-666	2
72	Rotor assembly	1-307-11-676	1-307-11-677	1

Table 1-14: Part description for an NPS 18 unidirectional LTM

Item number	Description	Part number for material 304 SS	Part number for material 316 SS	Quantity required
14	O-ring	1500093-022	1500093-022	1
40	Meter housing	Consult factory	Consult factory	1
41	Pickoff	899-00-201-00	899-00-201-00	2
42	Anti-rotation bracket clamp	899-10-230-66	899-10-230-66	1
53	Thrust washer	1-504-05-123	1-504-05-123	2
54	Shaft	1-504-05-657	1-504-05-657	1
60	Nut	1-561-76-088	1-561-76-088	2
62	Upstream cone	1-307-10-491	1-307-10-494	1
65	Downstream cone	1-307-10-591	1-307-10-594	1
68	Housing insert	1-307-03-009	1-307-03-029	1
69	Hanger blades	1-307-10-770	1-307-10-771	6
70	Cotter pin	1-562-05-656	1-562-05-656	2
71	Hanger hub	1-307-10-696	1-307-10-697	2
72	Rotor assembly	1-307-11-686	1-307-11-687	1

Table 1-15: Part description for an NPS 20 unidirectional LTM

Item number	Description	Part number for material 304 SS	Quantity required
14	O-ring	1500093-022	1
40	Meter housing	Consult factory	1
41	Pickoff	899-00-201-00	2
42	Anti-rotation bracket clamp	899-10-230-66	1
53	Thrust washer	1-504-05-124	2
54	Shaft	1-504-05-662	1
60	Nut	1-561-76-089	2
62	Upstream cone	1-307-10-492	1
65	Downstream cone	1-307-10-592	1
68	Housing insert	1-307-03-110	1
69	Hanger blades	1-307-10-775	6
70	Cotter pin	1-562-05-659	2
71	Hanger hub	1-307-10-698	2
72	Rotor assembly	1-504-05-662	1

Note

For material 316 SS part numbers, consult the factory.

Table 1-16: Part description for an NPS 24 unidirectional LTM

Item number	Description	Part number for material 304 SS	Quantity required
14	O-ring	1500093-022	1
40	Meter housing	Consult factory	1
41	Pickoff	899-00-201-00	2
42	Anti-rotation bracket clamp	899-10-230-66	1
53	Thrust washer	1-504-05-125	2
54	Shaft	1-504-05-667	1
60	Nut	1-561-76-090	2
62	Upstream cone	1-307-10-493	1
65	Downstream cone	1-307-10-593	1
68	Housing insert	1-307-03-111	1
69	Hanger blades	1-307-10-780	6
70	Cotter pin	1-562-05-665	2
71	Hanger hub	1-307-10-700	2

Table 1-16: Part description for an NPS 24 unidirectional LTM (continued)

Item number	Description	Part number for material 304 SS	Quantity required
72	Rotor assembly	1-307-11-701	1

Note

For 316 SS material part numbers, consult the factory.

Table 1-17: Part description for an NPS 3 bidirectional LTM

Item number	Description	Part number for material 304 SS	Part number for material 316 SS	Quantity required
14	O-ring	1500093-022	1500093-022	1
40	Meter housing	Consult factory	Consult factory	1
41	Pickoff	899-00-201-00	899-00-201-00	2
42	Anti-rotation bracket clamp	899-10-230-66	899-10-230-66	1
53	Thrust washer	1-504-05-114	1-504-05-114	2
54	Shaft	1-504-05-622	1-504-05-622	1
55	Bladed rotor	1-307-11-235	1-307-11-236	1
60	Nut	1-561-76-192	1-561-76-192	2
62	Upstream cone-rimmed	1-307-10-435	1-307-10-439	2
	Upstream cone-bladed	1-307-10-437	1-307-10-438	2
68	Housing insert	1-307-03-000	1-307-03-020	2
69	Hanger blades	1-307-10-735	1-307-10-736	6
71	Hanger hub	1-307-10-635	1-307-10-636	2
72	Rimmed rotor	1-307-11-237	1-307-11-238	1

Table 1-18: Part description for an NPS 4 bidirectional LTM

Item number	Description	Part number for material 304 SS	Part number for material 316 SS	Quantity required
14	O-ring	1500093-022	1500093-022	1
40	Meter housing	Consult factory	Consult factory	1
41	Pickoff	899-00-201-00	899-00-201-00	2
42	Anti-rotation bracket clamp	899-10-230-66	899-10-230-66	1
53	Thrust washer	1-504-05-115	1-504-05-115	2
54	Shaft	1-504-05-627	1-504-05-627	1
55	Bladed rotor	1-307-11-300	1-307-11-301	1
60	Nut	1-561-76-155	1-561-76-155	2
62	Upstream cone-rimmed	1-307-10-440	1-307-10-444	2
	Upstream cone-bladed	1-307-10-442	1-307-10-443	2
68	Housing insert	1-307-03-001	1-307-03-021	2
69	Hanger blades	1-307-10-740	1-307-10-741	6
71	Hanger hub	1-307-10-640	1-307-10-641	2
72	Rimmed rotor	1-307-11-302	1-307-11-303	1

Table 1-19: Part description for an NPS 6 bidirectional LTM

Item number	Description	Part number for material 304 SS	Part number for material 316 SS	Quantity required
14	O-ring	1500093-022	1500093-022	1
40	Meter housing	Consult factory	Consult factory	1
41	Pickoff	899-00-201-00	899-00-201-00	2
42	Anti-rotation bracket clamp	899-10-230-66	899-10-230-66	1
53	Thrust washer	1-504-05-117	1-504-05-117	2
54	Shaft	1-504-05-632	1-504-05-632	1
55	Bladed rotor	1-307-11-400	1-307-11-401	1
60	Nut	1-561-76-163	1-561-76-163	2
62	Upstream cone-rimmed	1-307-10-445	1-307-10-446	2
	Upstream cone-bladed	1-307-10-447	1-307-10-448	2
68	Housing insert	1-307-03-003	1-307-03-023	2
69	Hanger blades	1-307-10-745	1-307-10-746	6
71	Hanger hub	1-307-10-645	1-307-10-646	2
72	Rimmed rotor	1-307-11-402	1-307-11-403	1

Table 1-20: Part description for an NPS 8 bidirectional LTM

Item number	Description	Part number for material 304 SS	Part number for material 316 SS	Quantity required
14	O-ring	15000093-022	15000093-022	1
40	Meter housing	Consult factory	Consult factory	1
41	Pickoff	899-00-201-00	899-00-201-00	2
42	Anti-rotation bracket clamp	899-10-230-66	899-10-230-66	1
53	Thrust washer	1-504-05-118	1-504-05-118	2
54	Shaft	1-504-05-637	1-504-05-637	1
60	Nut	1-561-76-171	1-561-76-171	2
62	Upstream cone-rimmed	1-307-10-450	1-307-10-451	2
68	Housing insert	1-307-03-004	1-307-03-024	2
69	Hanger blades	1-307-10-750	1-307-10-751	6
71	Hanger hub	1-307-10-650	1-307-10-651	2
72	Rimmed rotor	1-307-11-404	1-307-11-405	1

1.7 Agency certifications for the Series 1500 LTM

Table 1-21: Agency certifications for the Series 1500 LTM

Certification type	Description	Certificate
Electrical	UL and CUL: Class I, Div. 1, Groups B, C & D	IECEX UL 11.0031X Rev. 7
	ATEX Ex db IIB T6 Gb Ex db IIC T6	DEMKO 03 ATEX 130946X Rev. 7
	IECEX Ex db IIB T6 Gb Ex db IIC T6 Gb	IECEX UL 11.0031X Rev. 7
	INMETRO (Brazil)	UL-BR 16.0354X Rev. 2016
Environmental	NEMA 4x (IP66)	DEMKO 03 ATEX 130946X Rev. 7
Pressure equipment	PED	CE 60685 (2014/68/EU Module H1)
Metrology	NMi TC7573 INMETRO (Brazil)	TC7573 Rev. 4 UL-BR 16.0354X Rev. 2016
Ambient temperature	-40 °C to 60 °C (-40 °F to 140 °F)	

2 Operating conditions and specifications

2.1 Operating conditions for the liquid turbine meter

Table 2-1: Operating conditions for the liquid turbine meter

Parameter type	Description
Fluid phase	Liquid
Fluid(s) measured	<ul style="list-style-type: none"> • Low/medium viscosity crude oils and condensates • Refined products and intermediates (e.g.: <i>gasoline, diesel, kerosene, light fuel oils, jet fuel, LPG, butanes, naphtha, alkylate, reformate, straight run gasoline, cat-cracked gasoline</i>) • Petrochemicals (e.g.: <i>benzene, toluene, xylenes, cumene, olefins, pyrolysis gasoline</i>) • Natural gas liquids
Process temperature (Carbon steel flanges)	-29 °C to 60 °C (-20 °F to 140 °F)
Optional process temperature (Carbon steel flanges)	-29 °C to 204 °C (-20 °F to 400 °F)
Process temperature (Stainless steel flanges)	-40 °C to 60 °C (-40 °F to 140 °F)
Optional process temperature (Stainless steel flanges)	-40 °C to 204 °C (-40 °F to 400 °F)
Fluid static pressure	The maximum working pressure for the Daniel Series 1500 Liquid Turbine Meter is based on the temperature/pressure rating of the ANSI B16.5 flanges. For maximum working pressures at intermediate temperatures refer to ANSI B16.5.
Fluid flow rate	100 BPH – 60000 BPH
Pressure drop	At maximum flow of normal flow range on water 4 psi.
Ambient temperature	-40 °C to 60 °C (-40 °F to 140 °F) (T_{amb} is an electrical specification)

Note

Remote mount the LME when the ambient temperature is above 60 °C (140 °F).

2.1.1 Design considerations

Some conditions to consider:

- Service operating pressure
- Service testing pressures
- Service process temperature and ambient site temperatures
- Chemical composition and fluid toxicity in operating conditions
- Traffic, wind and earthquake at loading site
- Adverse force or stress caused by inadequate supports, attachments, piping, etc.
- Corrosion, erosion, fatigue, etc.
- Decomposition of unstable fluids in operating and test conditions
- Possible damage from external fire
- Mass of fluid in process and test conditions



WARNING

FUNCTIONAL AND ENVIRONMENTAL HAZARD

Evaluate the functional and environmental conditions prior to installing a turbine meter. Install the turbine meter in a well designed piping system.

Failure to comply may result in death or serious injury.

2.1.2 Environmental conditions



WARNING

EQUIPMENT HAZARD

Never use this equipment for any purpose other than its intended use.

Failure to comply may result in death, serious injury and/or property damage.

Table 2-2: Environmental conditions

Parameter type	Description
Maximum working pressure	This is based on the temperature and pressure rating of the ANSI B16.5 flanges.
Severe service conditions	Ensure that piping or other attachments connected to the turbine meter are not under stress. The design of the turbine meter has not been assessed for the effects of wind, earthquake loading and/or other severe weather conditions.
Corrosive service	Select the material compatible with specific processes and atmospheric environments. Implement a periodic inspection and maintenance program to ensure that pressure-retaining components are free from corrosion and erosion.

Table 2-2: Environmental conditions (continued)

Parameter type	Description
Low and freezing temperatures	Low specific gravities or high viscosities reduce the flow range of the turbine meter. Refer to Operating parameters for the LTM for more information.
Populated areas	For new installations, locate the turbine meter to an area that has fewer than 10 buildings intended for human occupancy, within an area that extends 200 meters (220 yards) radially from the turbine meter. (Reference: Class 1 location. U.S. DOT, CFR Title 49: Part 192.5)
Closed, poorly ventilated areas and combustion sources	Install the turbine meter in a well ventilated area, not less than one meter (approximately 3 feet) from source of ignition or source of heat which might damage the unit.
Elevation	No limit.
Humidity	No limit.
Proximity to open flame	Provide fire prevention measures and equipment per local regulations.
Proximity to vehicular traffic	The design of the turbine meter has not been assessed for the effects of traffic loads.

2.1.3 Operating parameters for the LTM

Turbulent flow is detrimental and affects turbine meter linearity⁽¹⁾. It can cause non-homogeneous fluid cross-section and inconsistent back pressure, possibly resulting in cavitation⁽²⁾. To correct the flow characteristics, use upstream and downstream piping lengths per [Figure 2-3](#)).

Pipe fittings such as elbows and tees, and piping components such as valves and strainers should be located far enough upstream to dissipate any flow disturbance before it reaches the turbine meter. The use of flow straighteners or a flow conditioning plate greatly influences turbine meter performance.

Specific gravity

The turbine meter is affected by specific gravity which may influence performance. The effect of specific gravity on the turbine meter may be evidenced when it is below 0.7. As specific gravity decreases, the lift forces on the turbine blade decreases. Likewise as velocity decreases, lift forces decrease. These reduced lift forces are overtaken by bearing friction as low rates are approached. Subsequently, linearity deteriorates at low flow rates while measuring light fluids.

(1) Linearity is the total range of deviation of accuracy, expressed as a curve, between minimum and maximum flow rates. The ideal accuracy curve of a volumetric meter, such as the turbine, is a straight line denoting a constant meter factor.
 (2) Cavitation is the formation and collapse of vapor-filled cavities that result from a sudden decrease and increase in pressure. Refer to [Back pressure calculation](#) for more information.

Viscosity

Turbine meters are viscosity sensitive. As the metered fluid increases in viscosity, meter linearity declines. This effect on linearity is primarily due to a change in the fluid's velocity profile and skin friction between the fluid and the rotor blades.

Viscosities of 3 centipoise or less are seldom cause for concern. Consider all influential factors of higher levels. By anticipating the viscosity, maximum flow rate, flow range and desired linearity of the flow system, the user is able to determine the appropriate turbine meter for the application.

Back pressure

Maintain sufficient back pressure on the turbine meter to prevent flashing and cavitation. This is particularly important when measuring liquids with high vapor pressures, such as LPGs.

Equation 2-1: Back pressure calculation

$$P_b \geq 2\Delta p + 1.25p_e$$

P_b = Minimum back pressure, pounds per square inch gauge (psig)

Δp = Pressure drop through the meter at the maximum operating flow rate for the liquid being measured, pounds per square inch (psi).

P_e = Equilibrium vapor pressure of the liquid at the operating temperature, pounds per square inch absolute (psia), gauge pressure plus atmospheric pressure.

Figure 2-1 illustrates the effects of back pressure. Insufficient back pressure leads to measurement inaccuracy. The resulting flashing and cavitation is extremely damaging to the flow meter and pipe work.

Figure 2-1: Effects of back pressure

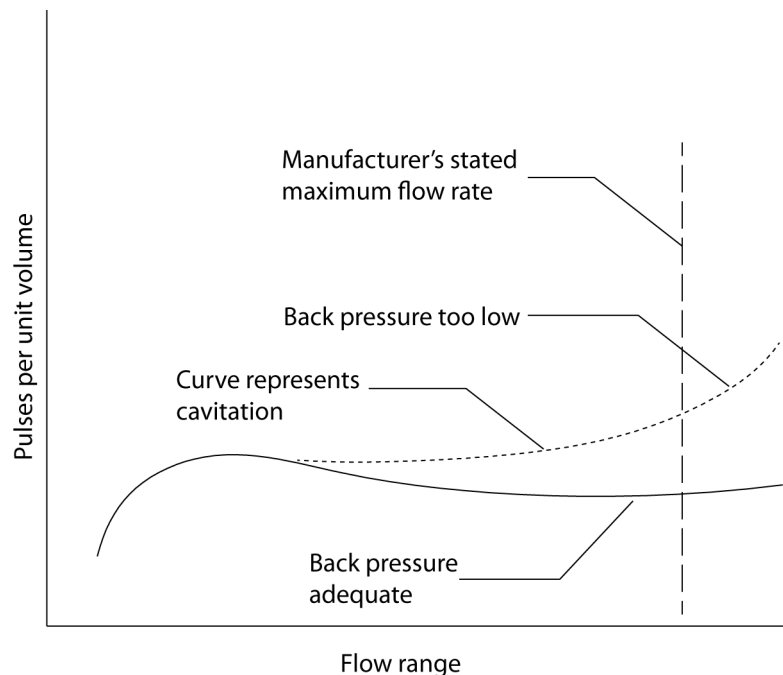

Back pressure calculation

Equation 2-2: Back pressure calculation

$$P_b \geq 2\Delta p + 1.25p_e$$

P_b = Minimum back pressure, pounds per square inch gauge (psig)

Δp = Pressure drop through the meter at the maximum operating flow rate for the liquid being measured, pounds per square inch (psi).

P_e = Equilibrium vapor pressure of the liquid at the operating temperature, pounds per square inch absolute (psia), gauge pressure plus atmospheric pressure.

Additional devices for accurate measurement

Valves

The metering system should have a flow rate control valve located at a convenient distance downstream of all measurement equipment. The function of the control valve is to limit and maintain system pressure on the meter. This avoids cavitation.

Valves should be capable of rapid, smooth opening and closing with positive shut-off.

- When used for intermittent flow, valves should be fast-acting and shock-free.
- Bypass lines should be equipped with blind or positive shutoff devices.
- Shut-off or control valves should be located downstream of the turbine meter.

Flow straightening devices

For accurate operation of the turbine meter, a flow conditioning plate, flow straightener (designed for the turbine meter), or a straight run of pipe (20 pipe diameters long) is required. All piping must be the same diameter as the turbine meter. Flow straightening devices must be installed directly upstream of the turbine meter and should not contain flow restricting devices which could cause reversal of the flow straightening effect.

Strainers

Install the correct size strainer upstream of the turbine meter to protect it from foreign material damage. Recommended mesh sizes include: 80 mesh for refined products, and 20 to 40 mesh for crude products (depending on the product being measured).

Clean the strainer basket regularly, to prevent filling and rupturing of the screen.

Pressure gauges installed on both sides of the strainer monitor differential pressure across the strainer. High pressure differential caused by filling of the basket or occlusion of foreign material can cause a strainer basket rupture, resulting in possible turbine meter damage.

2.2 Specifications for the LTM

2.2.1 Interface parameters

 **WARNING**

EXCEEDING PARAMETER HAZARD

Turbine meter parameters are set for safe equipment use. Do not exceed these parameters.

Failure to comply may result in death, serious injury and/or damage to the equipment.

Table 2-3: 2818 Dual channel preamplifier performance

Parameter type	Description
Inputs	Supply voltage: 10-30 VDC Sensor type: Reluctance Signal: Sine wave Preamplifier sensitivity: 40 mV peak to peak minimum Temperature range: -40 °C to 85 °C (-40 °F to 185 °F)
Outputs	Powered pulse output: <ul style="list-style-type: none">• Type: Square wave• Frequency range: 0 to 5 kHz• Amplitude: 0 to 5 V• 1000 Ohm internal pull-ups, 20 mA, max.
	Variable voltage output: <ul style="list-style-type: none">• Type: Square wave• Frequency range: 0 to 5 kHz• Amplitude: 0 to Supply voltage• 1000 Ohm internal pull-ups, 70 mA, max.
Construction	Delrin housing Solid epoxy encapsulation

Table 2-4: 2415 Intrinsically safe preamplifier performance

Parameter type	Description
Inputs	Supply voltage: 13-25 Vdc @ ≤ 12 mA Sensor type: Reluctance Signal: Sine wave Preamplifier sensitivity: <ul style="list-style-type: none"> • 60 mVpp • 10Hz - 1KHz (60mVpp) • 10Hz - 3KHz (115mVpp) • 10Hz - 5KHz (200mVpp) Temperature range: -40 °C to 85 °C (-40 °F to 185 °F)
Outputs	Powered pulse output: <ul style="list-style-type: none"> • Type: Square wave • Frequency range: ~5 Hz to 5 kHz • Amplitude: 0 to 5 V
Construction	Delrin housing Solid epoxy encapsulation

Table 2-5: 1815B Zero crossing preamplifier performance

Parameter type	Description
Inputs	Supply voltage: 14-30 VDC Sensor type: Reluctance Signal: Sine wave Preamplifier sensitivity: 40 mVpp Temperature range: -40 °C to 85 °C (-40 °F to 185 °F)
Outputs	Powered pulse output: <ul style="list-style-type: none"> • Type: Square wave • Frequency range: ≤ 5 kHz • Amplitude: 0-12 V
Construction	Delrin housing Solid epoxy encapsulation

Table 2-6: 1817X Bi-directional preamplifier performance

Parameter type	Description
Inputs	Supply voltage: 11.5-36 VDC Sensor type: Reluctance Signal: Sine wave Preamplifier sensitivity: 40 mVpp Temperature range: -40 °C to 85 °C (-40 °F to 185 °F)

Table 2-6: 1817X Bi-directional preamplifier performance (continued)

Parameter type	Description
Outputs	Powered pulse output: <ul style="list-style-type: none"> Type: Square wave Frequency range: ≤ 5 kHz Amplitude: 0-Vs
Construction	Delrin housing Solid epoxy encapsulation

Wiring and cable connections

The pickoff input signal connections are made at terminal strip connection TB2 for Channel A, and TB3 for Channel B. Power supply and output signal connections are made at terminal strip TB1. Refer to [Table 2-7](#), [Table 2-8](#), [Table 2-9](#) and [Table 2-10](#).

Important

- For single channel wiring use multi-conductor control and instrumentation cable (18AWG), or equivalent.
- Earth ground shield at one end only.
- Insulate the shield at the other end.
- For dual channel wiring use multi-conductor control and instrumentation cable (18AWG), or equivalent.
- Connect both shields to earth ground at one end of the cables and insulate the shields at the other end.
- The LME housing should be at earth ground.

Table 2-7: 2818 Dual channel preamplifier configuration

Plug component designator	Terminal connections	Description
TB1 - Customer connection	1	+10 to 30 Vdc
	2	Common
	3	Common
	4	Channel A output
	5	Channel B output
	6	TTL out A
	7	TTL out B
TB2 - Channel A pickoff (1)	1	White
	2	Red
TB3 - Channel B pickoff (1)	1	White
	2	Red

Table 2-8: 2415 Intrinsically safe preamplifier configuration

Designator	Terminal connections	Description
Customer connection	1	Supply voltage
	2	Common
	3	Output signal (half frequency)
	4	Output signal
Pickoff (1)	5	White
	6	Red

Table 2-9: 1815B Zero crossing preamplifier configuration

Designator	Terminal connections	Description
Customer connection	1	Supply voltage
	2	Common
	3	Output signal (x1)
	4	Output signal (x2)
Pickoff (1)	5	White
	6	Red

Table 2-10: 1817X Bi-directional preamplifier configuration

Designator	Terminal connections	Description	
Customer connection	1	Supply voltage	
	2	Common	
	3 Direction	Forward (A before B): OVDC, OC	
		Reverse (B before A): Vs, OC	
	4	Channel A output	
	5	Channel B output	
6	Optional (X2)		
Pickoff (2)	7	White	
	8	Red	
	9	White	
	10	Red	

Pickoff coils

The Series 1500 LTM has the capacity for dual pickoff coils mounted 90° electrically out of phase. Each pickoff produces a low level sine wave signal which varies in amplitude (mV) and frequency (Hz) proportional to the velocity of the turbine blades. This signal information is coupled to the input terminals of the preamplifier.

The optional dual LME LTM can be configured with four pickoff coils, each pair mounted 90° electrically out of phase.

Induced interference

The LTM should be located as far as possible from any electrical equipment such as motors, solenoids or relays which could induce an interference signal into the turbine meter pickoff coil. High amplitude interference introduced into the preamplifier can result in interference with the flow signal. Proper shielding and an earth grounded LME housing will greatly reduce the possibility of induced interference.

Accessory hookup

It is important that the correct service manual be referenced before attempting to use accessories or instrumentation with the Series 1500 LTM. Contact the factory or nearest Emerson service office if service manuals for were not received at the time of purchase or delivery.

LTM flange type

The mechanical connections for a Series 1500 LTM NPS 3 through 24 are standard class 150, 300, 600 and 900 ANSI S.O. R.F. flanges, which are available in stainless steel and carbon. For class ratings 1500 and 2500 Daniel offers weld neck RTJ Daniel type flanges as standard. Other types of flange connections are available per customer request. For other ANSI ratings or flanges consult the factory engineers. For maximum working pressures at intermediate temperatures refer to ANSI B16.5.



WARNING

HIGH PRESSURE HAZARD

Choose the appropriate size and material of the flange for their piping requirements. Choosing an incorrect flange may cause a pressure leak, resulting in death or serious injury.

2.2.2 Requirements and limitations for installation

Figure 2-2: Typical installation for a Series 1500 LTM

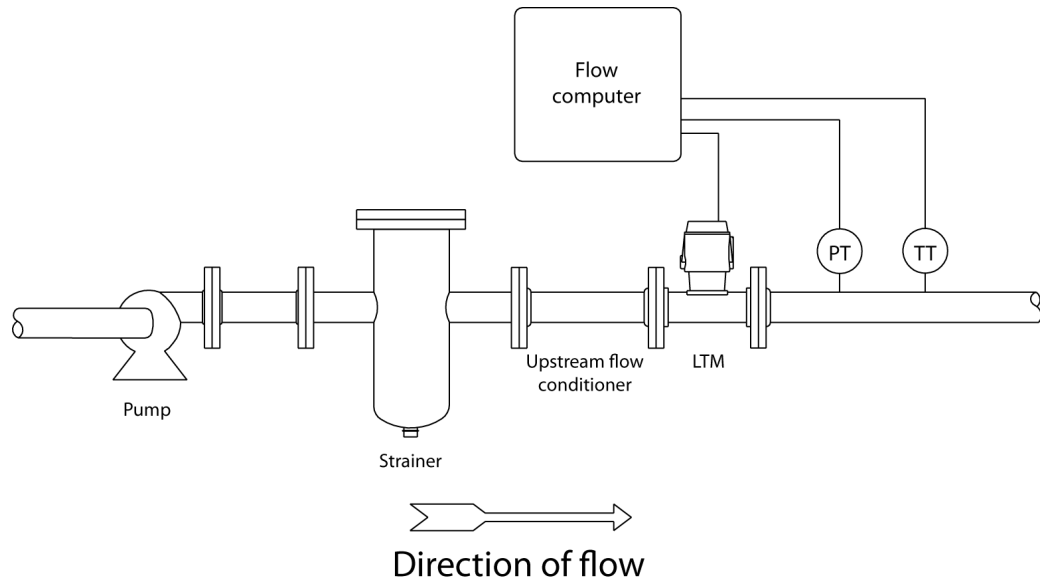

- Note the direction of flow indicated on the plate near the inlet flange and install accordingly.
- New installations: Flush lines thoroughly to rid piping of potentially damaging foreign material such as welding bead, pipe scale, etc. before the turbine meter is placed into service.

Important

A spool piece installed in place of the turbine meter is recommended for this procedure.

NOTICE

Comply with local government regulations and company requirements.

Minimum clearances for installation, operation and maintenance

Below is the approximate shipping dimensions and weight for the Series 1500 LTM NPS 3-24. Consult the factory for certified dimension prints.

Figure 2-3: Dimensions for the Series 1500 LTM NPS 3-24

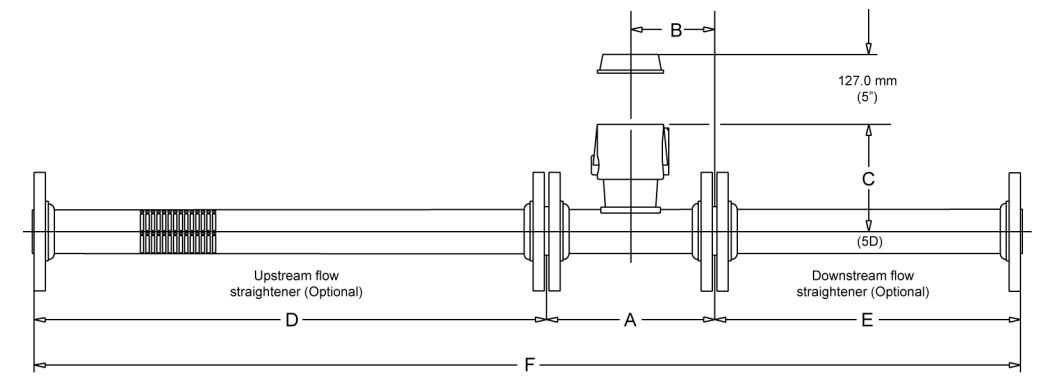

Table 2-11: Flow meter and flow straightening section dimensions for the Series 1500 LTM NPS 3-24

Size	A		B		C	
	Inches	mm	Inches	mm	Inches	mm
3	10	254.0	5	127.0	11	278.6
4	12	304.8	6	152.4	12	297.7
6	14	355.6	7	177.8	13	324.7
8	16	406.4	8	203.2	14	350.1
10	20	508.0	10	254.0	15	377.1
12	24	609.6	12	304.8	16	402.5
16	32	812.8	16	406.4	17	443.7
18	36	914.4	18	457.2	18	469.1
20	40	1016	20	508	19	494.5
24	48	1219	24	610	21	545.3

Table 2-12: Flow meter and flow straightening section dimensions for the Series 1500 LTM NPS 3-24

Size	D		E		F	
	Inches	mm	Inches	mm	Inches	mm
3	30	762	15	381	55	1397.0
4	40	1016	20	508	72	1828.8
6	60	1524	30	762	104	2641.6

Table 2-12: Flow meter and flow straightening section dimensions for the Series 1500 LTM NPS 3-24 (continued)

Size	D		E		F	
	Inches	mm	Inches	mm	Inches	mm
8	80	2032	40	1016	136	3454.4
10	100	2540	50	1270	170	4318.0
12	120	3048	60	1524	204	5181.6
16	160	4064	80	2032	272	6908.8
18	180	4572	90	2286	306	7772.4
20	200	5080	100	2540	340	8636.0
24	240	6096	120	3048	408	10363.2

Table 2-13: Weight table for the stainless steel LME

Size	ANSI class 150		ANSI class 300		ANSI class 600	
	Lbs	Kg	Lbs	Kg	Lbs	Kg
3	42	19.1	52	23.6	56	25.6
4	56	25.6	78	35.6	97	44.1
6	89	40.6	122	55.6	180	81.6
8	131	59.6	191	86.6	285	129.6
10	217	98.6	290	131.6	468	212.6
12	331	150.6	444	201.6	598	271.6
16	736	334.6	846	384.6	1264	574.6
18	1104	501.6	1165	529.6	1662	755.6
20 ⁽¹⁾	CF	CF	CF	CF	CF	CF
24 ⁽¹⁾	CF	CF	CF	CF	CF	CF

(1) CF: Consult factory

3 Turbine meter handling

3.1 Receive the turbine meter

 **WARNING**

EQUIPMENT HANDLING AND OPERATING HAZARD

Wear personal protective equipment appropriate to the situation when working with the turbine meter. Adhere to all safety standards and best practices for operating the equipment.

Failure to comply may result in death or serious injury.

3.1.1 Unpack and inspect the turbine meter

Inspect the turbine meter upon receiving at the customer facility.

Procedure

1. Remove the turbine meter from the shipping container.
2. Inspect the turbine meter for damage.
3. See [Installation procedure](#) for Installation procedure.

3.2 Store the turbine meter

3.2.1 Rust inhibitor

Apply light oil or rust inhibitor on surfaces that are in contact with the environment only if the turbine meter body is carbon steel.

3.2.2 Pack the turbine meter

Procedure

1. Use stretch wrap (not adhesive) to attach the correct size flange cover to the turbine meter end flanges. This protects the unpainted surfaces of the flange sealing.
2. A flush contact between the flange cover and the flange sealing face is important.

3.2.3 Storage conditions

Store the turbine meter in a safe area to avoid damage.

 **WARNING**
CRUSHING HAZARD

During turbine meter installation or removal, always place the unit on a stable platform or surface that supports its assembled weight.

Failure to comply could allow the turbine meter to roll, resulting in death, serious injury or equipment damage.

Table 3-1: Meter storage conditions

Parameter type	Description
Storage environment	For long term storage, it is recommended that the complete meter housing assembly be stored under cover in a controlled environmental atmosphere in the original packaging. The storage temperature limits are -40 °C to 60 °C (-40 °F to 140 °F).
Shelf life for elastomers	Elastomers are only installed in a flameproof pad and a threaded top cover. These parts are not considered to be under pressure in normal conditions. O-rings must be inspected for wear or damage during disassembly of the cover or housing and right before assembling the unit. If any elastomer is damaged, it must be replaced. FKM elastomers have an unlimited shelf life.
Lubrication	The LME is offered in stainless steel. Use petroleum jelly lubrication when assembling the cover to the LME housing. Other components, except O-rings do not require lubrication.
Inspect stored equipment	Examine the internal surfaces and flange faces of the turbine meter at least once every three months. Repack the turbine meter per original conditions.
Labels and nameplates	Do not remove nameplates or labels. Doing so will void the turbine meter warranty.
Stacking	When stacking equipment, follow all safety standards, taking into account the type of box used, the maximum height of the equipment, the maximum number of boxes stacked, etc.

4 Prepare the turbine meter for use

4.1 Lifting conditions

 **WARNING**

CRUSHING HAZARD

During turbine meter installation or removal, always place the unit on a stable platform or surface that supports its assembled weight.

Failure to comply could allow the turbine meter to roll, resulting in death, serious injury or equipment damage.

 **WARNING**

LIFTING HAZARD

The lifting instructions are for installation and removal of the Daniel Liquid Turbine Meter only and do not address lifting the turbine meter while it is attached or bolted to piping.

Failure to comply with these instructions may result in death, serious injury, or equipment damage.

 **CAUTION**

FORKLIFT HAZARD

Do not insert the forks of a forklift into the bore when moving the turbine meter.

Inserting the forks may cause the meter to become unstable, resulting in serious injury or equipment damage.

Table 4-1: Lifting and installation conditions

Conditions	Description
Lighting and ventilation	Install the turbine meter in a well lit and ventilated location, not less than one meter (approximately three feet) from source of ignition or source of heat which might damage the unit.
Work area clearances and installation height restrictions	Refer to Minimum clearances for installation, operation and maintenance .
Surface considerations	Stable surface.
Soil/floor loadings and product/piping support	Follow local procedures that meet the standards for soil/floor loading and product/piping support.

4.2 Lifting requirements for personnel

WARNING

EQUIPMENT HANDLING AND OPERATING HAZARD

Wear personal protective equipment appropriate to the situation when working with the turbine meter. Adhere to all safety standards and best practices for operating the equipment.

Failure to comply may result in death or serious injury.

Best lifting practices

WARNING

LIFTING HAZARD

The lifting instructions are for installation and removal of the Daniel Liquid Turbine Meter only and do not address lifting the turbine meter while it is attached or bolted to piping.

Failure to comply with these instructions may result in death, serious injury, or equipment damage.

4.2.1 Equipment required to lift the turbine meter

WARNING

CRUSHING HAZARD

During turbine meter installation or removal, always place the unit on a stable platform or surface that supports its assembled weight.

Failure to comply could allow the turbine meter to roll, resulting in death, serious injury or equipment damage.

Important

Prior to lifting the unit refer to [Minimum clearances for installation, operation and maintenance](#) for the assemble weight.

The following instructions provide general guidelines using lifting slings only on the Daniel turbine meter. Use appropriately rated lifting slings when lifting the turbine meter.

Safety precautions using appropriately rated lifting slings

When lifting a liquid turbine meter by itself, Emerson recommends using lifting slings appropriately positioned at designated areas of the turbine meter.

! **WARNING**
LIFTING HAZARD

The lifting instructions are for installation and removal of the Daniel Liquid Turbine Meter only and do not address lifting the turbine meter while it is attached or bolted to piping.

Failure to comply with these instructions may result in death, serious injury, or equipment damage.

Read and follow the safety precautions listed below.

- Never attempt to lift the turbine meter by wrapping slings around the electronics enclosure.
- Never attempt to lift the turbine meter using only one sling around the turbine meter. Always use two slings wrapped around each end of the body (refer to [Figure 4-1](#)). A choker style sling with a spreader bar is recommended.

Figure 4-1: Correct sling attachment

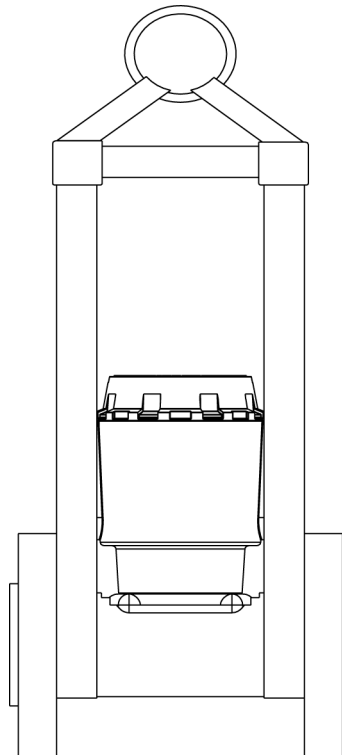

- Prior to use, visually inspect the slings for any signs of abrasion or other damage. Refer to the sling manufacturer for inspection procedure specific to the sling you are using.

- Only use slings with ratings that exceed the weight to be lifted. Reference your company's standards for safety factors that must be included when calculating the load rating.
- If the slings do come in contact with the electronics, use a spreader bar on the sling to prevent contact with the electronics.

Important

Never allow the slings to come in contact with the electronics enclosure. Damage to the enclosure may occur.

Figure 4-2: Incorrect sling attachment

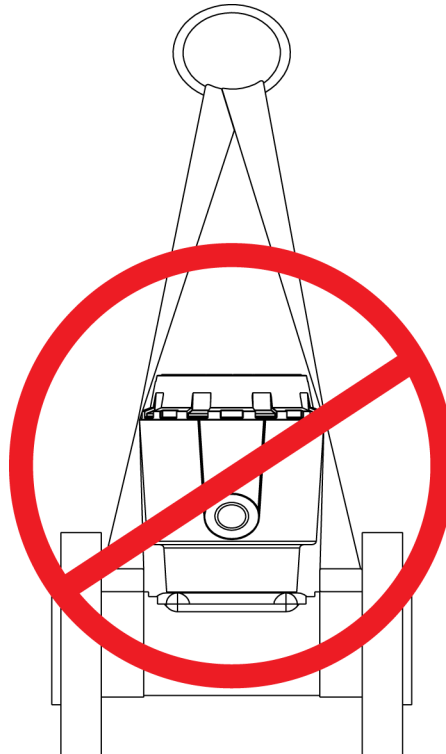

! CAUTION
LIFTING HAZARD

Lifting the turbine meter with the upper enclosure installed but without the bolts installed, may cause the electronics to fall.

Doing this may cause injury and/or damage the equipment.

- Never apply shock loads to the turbine meter. Always lift the turbine meter gradually. If shock loading occurs, inspect the slings per manufacturer's recommendations prior to further use.

4.3 Configuration of the turbine meter

The Emerson factory configures the turbine meter internal components. Inspect the internal components before installation.

4.3.1 Orientation and position of the turbine meter

Flow direction

Turbine meters can be used for uni-directional or bi-directional flows. The design of the internal features of the meter housing and the internal components depend on the desired configuration. Install the LTM carefully so it complies with the correct inlet and outlet sides (See label on the turbine meter for inlet direction).

Flow conditioning

The flow stream must be free of swirl for a turbine meter to perform consistently and accurately. The internal assembly supports of a turbine meter offer a slight straightening effect. If additional flow conditioning is required, use straightening vanes or tube bundles. Refer to API MPMS, Chapter 5, Section 3.

A flow conditioning plate is available for all standard series 1500 LTM, NPS 3 through 8. It is designed to eliminate product flow characteristics such as liquid swirl and non-uniform velocity profiles (induced by piping configurations and other elements of the system) that may impede accurate measurement within the turbine meter run.

The plate is installed directly into the inlet of the turbine meter. Due to the flow conditioning influence on the incoming product, the need for upstream flow straightening piping is reduced. It is recommended that a minimum of five pipe diameters be maintained upstream and downstream of the turbine meter to ensure accurate operation. Actual length is determined by piping requirements specific to the application.

4.3.2 Piping recommendations

Figure 4-3: Typical installation for a Series 1500 LTM

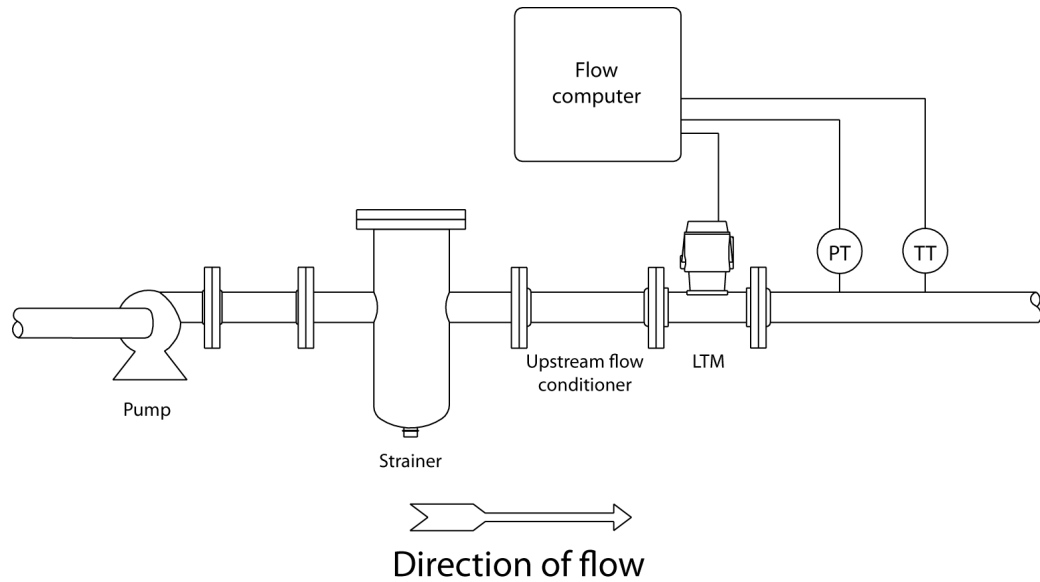

- Note the direction of flow indicated on the plate near the inlet flange and install accordingly.
- New installations: Flush lines thoroughly to rid piping of potentially damaging foreign material such as welding bead, pipe scale, etc. before the turbine meter is placed into service.

Important

A spool piece installed in place of the turbine meter is recommended for this procedure.

NOTICE

Comply with local government regulations and company requirements.

Important

Ensure that piping or other attachments connected to the turbine meter are not under stress.

Important

Provide fire prevention measures and equipment per local regulations.

4.3.3 Calibration options for the turbine meter

Daniel offers a standard six-point calibration (from 10% to 100%); or can provide other customer requested calibration data.

Table 4-2: Standard calibration for a Daniel Liquid Turbine Meter

Calibration type	Description
Linearity	NPS 3-24 ± 0.15%: Standard NPS 3-24 ± 0.10%: Premium NPS 3-24 ±0.07%: Premium
Repeatability	± 0.02%

4.3.4 Preampifier power requirements

Table 4-3: Preampifier power requirements

Power requirement type	Description	
Pickoff	<ul style="list-style-type: none"> Type: 2-wire reluctance Resistance: 600-900 Ohms Inductance: 250 mH max Output: Sinusoidal 40mV p-p minimum @ minimum flow with preamplifier load Optional: 2, 3* or 4* pickoff coils *with dual LME 	
Dual channel preamplifier	Inputs	Supply voltage: 10-30 VDC Sensor type: Reluctance Signal: Sine wave Preamplifier sensitivity: 40 mV peak to peak minimum Temperature range: -40 °C to 85 °C (-40 °F to 185 °F)
	Outputs	Powered pulse output: <ul style="list-style-type: none"> Type: Square wave Frequency range: 0 to 5 kHz Amplitude: 0 to 5 V 1000 Ohm internal pull-ups, 20 mA, max. Variable voltage output: <ul style="list-style-type: none"> Type: Square wave Frequency range: 0 to 5 kHz Amplitude: 0 to Supply voltage 1000 Ohm internal pull-ups, 70 mA, max.

Table 4-3: Preamplifier power requirements (continued)

Power requirement type	Description	
Intrinsically safe preamplifier	Inputs	Supply voltage: 13-25 Vdc @ ≤12 mA Sensor type: Reluctance Signal: Sine wave Preamplifier sensitivity: <ul style="list-style-type: none"> • 60 mVpp • 10Hz - 1KHz (60mVpp) • 10Hz - 3KHz (115mVpp) • 10Hz - 5KHz (200mVpp) Temperature range: -40 °C to 85 °C (-40 °F to 185 °F)
	Outputs	Powered pulse output: <ul style="list-style-type: none"> • Type: Square wave • Frequency range: ~5 Hz to 5 kHz • Amplitude: 0 to 5 V
Zero crossing preamplifier	Inputs	Supply voltage: 14-30 VDC Sensor type: Reluctance Signal: Sine wave Preamplifier sensitivity: 40 mVpp Temperature range: -40 °C to 85 °C (-40 °F to 185 °F)
	Outputs	Powered pulse output: <ul style="list-style-type: none"> • Type: Square wave • Frequency range: ≤ 5 kHz • Amplitude: 0-12 V
Bi-directional preamplifier	Inputs	Supply voltage: 11.5-36 VDC Sensor type: Reluctance Signal: Sine wave Preamplifier sensitivity: 40 mVpp Temperature range: -40 °C to 85 °C (-40 °F to 185 °F)
	Outputs	Powered pulse output: <ul style="list-style-type: none"> • Type: Square wave • Frequency range: ≤ 5 kHz • Amplitude: 0-Vs

4.3.5 Grounding

Ground the turbine meter electronics internally for safe operation. Connect a wire to the chassis ground lug located inside the LME as the primary ground. A secondary ground is located outside of the LME. Refer to [Figure 4-4](#) and [Figure 4-5](#). Digital grounds should never be connected to chassis ground.

Figure 4-4: External ground lug

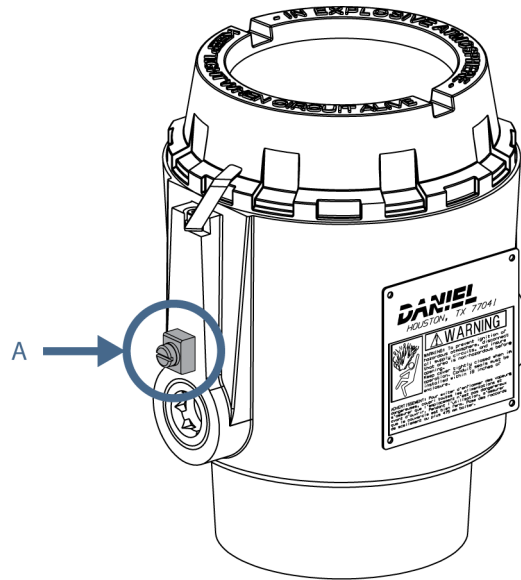

A. External ground lug

Figure 4-5: Internal ground lug

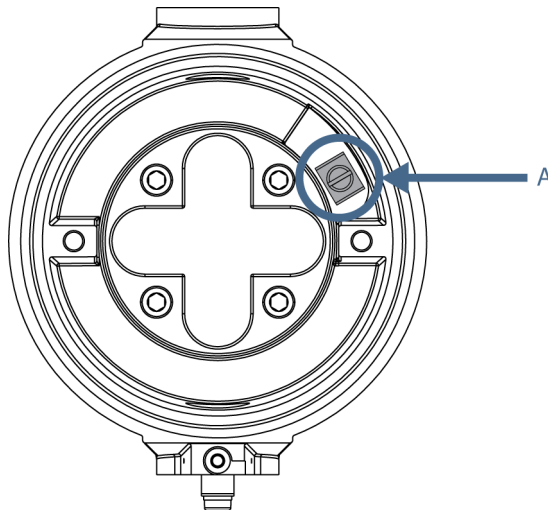

A. Internal ground lug

Important

Use the internal grounding terminal as the primary equipment ground. The external terminal is only a supplemental bonding connection where local authorities permit or require such a connection.

4.3.6 LME communication connectivity restrictions

The pickoff input signal connections are made at terminal strip connection TB2 for Channel A, and TB3 for Channel B. Power supply and output signal connections are made at terminal strip TB1. Refer to [Table 2-7](#), [Table 2-8](#), [Table 2-9](#) and [Table 2-10](#).

Important

- For single channel wiring use multi-conductor control and instrumentation cable (18AWG), or equivalent.
 - Earth ground shield at one end only.
 - Insulate the shield at the other end.
 - For dual channel wiring use multi-conductor control and instrumentation cable (18AWG), or equivalent.
 - Connect both shields to earth ground at one end of the cables and insulate the shields at the other end.
 - The LME housing should be at earth ground.
-

4.3.7 RME communication connectivity restrictions

The RME must follow all the connectivity restrictions that are applicable to the LME as well as the transmission distance restrictions listed on [Table 4-4](#).

Table 4-4: Installation dimensions for the RME

Device	Transmission distance
Pickoff to RME	6.1 meters (20 ft.) maximum from RME dual channel
Preamplifier to receiver	1525 meters (5,000 ft.) maximum

Figure 4-6: Typical installation for the RME

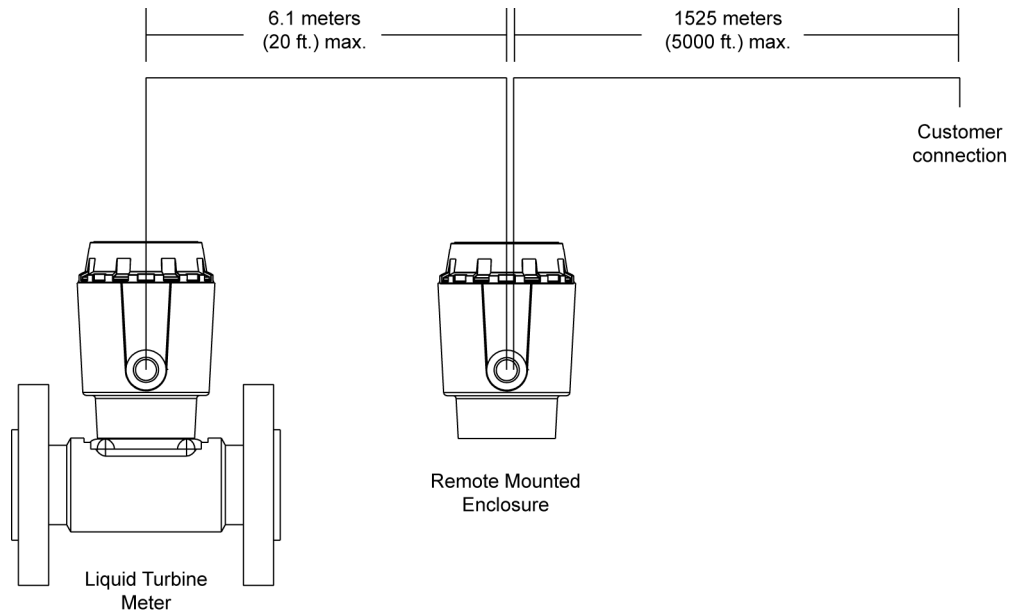

4.3.8 Install the security seal

Security seals protect the integrity of the turbine meter metrology and prevent preamplifier and pickoff tampering. Follow the steps below to seal the electronics enclosure of the Daniel 1500 LTM after commissioning. The security seal wires are commercially available.

! **CAUTION**
CUTTING HAZARD

Sharp edges may be present on the band shrouds. Wear appropriate personal protective equipment when working on the turbine meter.

Failure to comply may cause serious injury.

Figure 4-7: Security seal wire

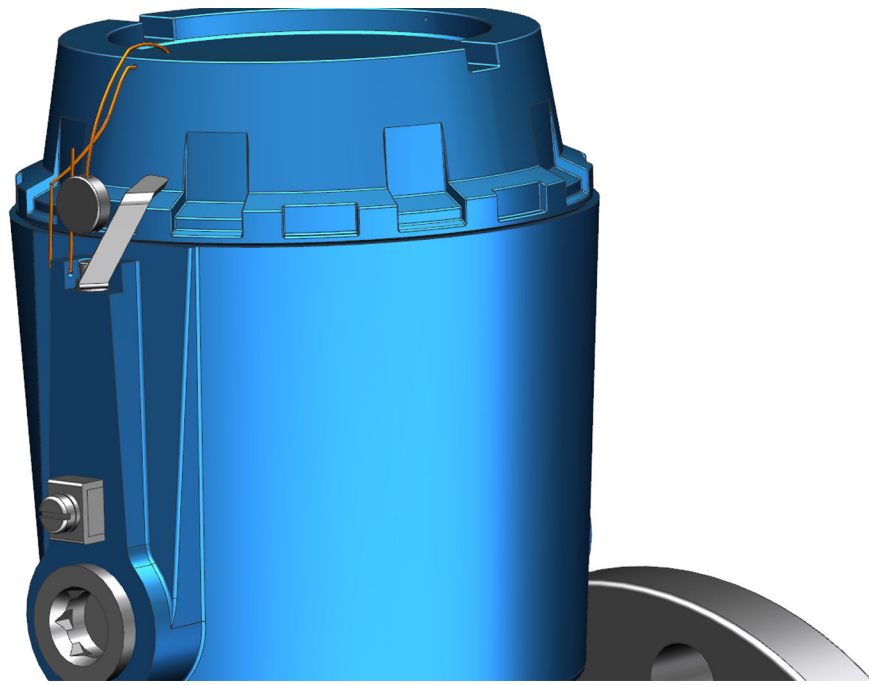

Follow the steps below to seal the electronics enclosure.

Procedure

1. Rotate the end cap clockwise, fully closing and compressing the end cap seal. Install the security latch using a 3mm Allen wrench.
2. Install the security seal wire into and through one of the two holes in the end cap and the housing. Choose holes that minimize counterclockwise rotation of the end cap when the security wire is taut (maximum wire diameter 2.0 mm, .078 inch).
3. Adjust the security wire, removing all slack and thread into the lead seal.
4. Cut the ends of the wire to remove any excess wire.

Part II

Install

5 Installation prerequisites

5.1 Pre-start checks

Procedure

1. Inspect all electrical connections to ensure compliance to electrical codes and safety regulations.
2. Inspect all bolts used to secure the turbine meter in line to ensure that correct mounting procedures have been followed and that flange connections are leak-free.
3. Evaluate the system setup to ensure that all components are in the correct sequence for accurate product measurement: isolation valve, strainer, flow straightener, turbine meter, downstream section, control valve, etc.
4. Ensure that the supply voltage to the preamplifier is within the 10-30 VDC range.

5.2 Torque information

NOTICE

When installing this equipment, bolting must conform to the requirements of ASME B16.5 paragraph 5.3 and to the material requirements of ASME B16.5 Table 1B. Gaskets must conform to the requirements of ASME B16.20. This is applicable for class 150 to 2500. Consult factory for higher nominal pressure.

Important

When installing flange, follow the customer's best internal practice procedures.

5.3 Tools required for LME disassembly/assembly

Use the following tools for disassembly/assembly of the turbine meter electronics (LME):

- 6 mm Allen key
- 3 mm Allen key
- 2.5 mm Allen key
- 3/32 Allen key
- 10 mm Allen key
- Phillips screwdriver
- 3.5 mm Flathead screwdriver
- 10 mm Flathead screwdriver

6 Installation procedure

6.1 Cathodic protection

Table 6-1: Standards for cathodic protection

Material	Daniel standard cathodic protection ⁽¹⁾
Carbon steel	Zinc Phosphate

(1) Consult the factory for other protection.

6.2 Mechanical components assembly

Install the meter housing (e.g., flanges) onto the pipeline.

The meter housing internal components are assembled by the factory. The components do not need to be uninstalled or reinstalled unless maintenance is required.

6.2.1 Fasteners

Property class of the fastener is in accordance with ASME B16.5.

Stud bolt and nut types

All fasteners (nuts and studs) used in assembling Daniel turbine meters are made of one of the materials listed in the table below.

Table 6-2: Bolt material selection

Bolt material selection	Description
ASTM SA 193 Grade B7 <63.5 mm (<2.5 in.)	High strength low alloy steel
ASTM SA 193 Grade B7M <63.5 mm (<2.5 in.)	Controlled strength low alloy steel
ASTM SA 320 Grade L7 <63.5 mm (<2.5 in.)	High strength low alloy low temperature steel
ASTM SA 320 Grade L7M <63.5 mm (<2.5 in.)	Controlled hardness low temperature steel
ASTM SA 449 <25.4 mm (<1.0 in.)	Quenched and tempered steel
ASTM SA 453 Grade 660	High temperature stainless steel

Selection of flange stud bolts and nuts

- Select all fasteners (nuts and studs) used in a hydrostatic test according to the flange size and quantity listed in ASME ANSI B16.5.
- Use the shortest stud bolt that permits full engagement of the thread through the nut by hand-tightening.
- Use only clean, rust-free nuts and stud bolts.

Important

Ensure that once the nut is tightened, two threads outside the nut are exposed. The only exception is when a flange requires hydraulic bolt tensioning. The manufacturer of the hydraulic bolt tensioning equipment will specify number of exposed threads outside the nut.

- Do not use damaged or worn stud bolts or nuts.
- Do not use nuts or stud bolts that do not fit correctly together.
- Do not use nuts or stud bolts without grade or type identification.
- Do not mix nuts or stud bolts of different coatings. Different nut and stud bolt coatings require different torques to achieve the same bolt tension.
- Do not assemble nuts with the identification hard stamp against the back face of the flange

Flange stud bolt and nut storage

Remove each nut and bolt as a pair. Thread the matching nut back onto the bolt. Stack them in a fashion that will not cause thread damage.

Reuse of flange stud bolts and nuts

Daniel Quality Control permits the reuse of threaded fasteners under the following conditions:

- Fasteners are clean, free of corrosion, paint, thread damage, cracks, teeth marks (caused by wrenches) or other signs of damage.
- Fasteners are not tightened to or beyond their yield strength.
- Fasteners have not lost their coating.

Compare the threads of a used stud bolt with the thread of a new stud bolt. Finger-tighten the nut over the entire length of the bolt.

6.3 Assemble the electronic components

Follow the procedure below to install the LME and/or the RME electronics.

Prerequisites

 **WARNING**
VOLTAGE HAZARD

Disconnect equipment from power before opening the LME and/or RME. Do not open them while power is on and an explosive gas atmosphere is present.

Failure to comply may result in death or serious injury.

Procedure

1. Remove the security seal wire.
2. Remove the security latch using the 3 mm Allen key.

Important

The security latch prevents the removal of the LME cover in a flameproof environment.

3. Unscrew the end cap and remove it from the housing.
4. Unplug one or two $\frac{3}{4}$ -14 NPT ports (as required) and install the conduit (provided by the customer) to the enclosure and tighten.
5. Install the electronics according to [Wiring and cable connections](#). Consult with Emerson if the preamplifier acquired is other than a dual channel preamplifier.



WARNING

SHOCK AND EXPLOSION HAZARD

Verify that the LME and/or RME is grounded.

Failure to comply may cause death, serious injury and/or equipment damage.

6. Screw the end cap to the housing. Hand-tighten, only if required.
7. Install the security latch.

7 Testing

7.1 Test the turbine meter

7.1.1 Commission the turbine meter

After installation, commission the turbine meter to ensure that the equipment is working properly.

Procedure

1. Inspect all electrical connections to ensure compliance with electrical codes and safety regulations.
2. Inspect all flange bolts used to secure the turbine meter in-line to ensure that correct mounting procedures are followed and that flange connections are leak-free.
3. Evaluate the system setup to ensure that all components are in the correct sequence for accurate product measurement: isolation valve, strainer, flow straightener, turbine meter, downstream section, control valve, etc.
4. Ensure that the supply voltage to the preamplifier is within the 10-30 VDC range.

Part III

Operate

8 Operation parameters

8.1 Operation overview

The Daniel Series 1500 LTM is a volumetric flow measuring and transmitting device that produces an output signal proportional to the rate-of-flow of the liquid being measured. The primary output is a single or dual high resolution signal that is amplified and shaped by an integral preamplifier mounted within an explosion-proof housing. This square wave pulse can be fed directly to remote totalizers, digital readout devices or control instrumentation.



WARNING

EXCEEDING PARAMETER HAZARD

Turbine meter parameters are set for safe equipment use. Do not exceed these parameters.

Failure to comply may result in death, serious injury and/or damage to the equipment.

8.2 Turbine meter normal operation

After any reparation or installation of a new turbine meter, calibrate it to confirm the meter factor or establish a new meter factor for the turbine meter as it is installed at the site.

The customer has various options to calibrate their turbine meter. Either by their on site stationary small volume bidirectional - unidirectional or master meter. This calibration service is also available from Daniel.

During operation, the customer data center will download to the terminal automated system (TAS) the orders to be schedule to the pipeline to various customers. TAS and turbine meter flow computer electronics monitor, control and collect batch volumes on each order and return all information as if it occurs to the TAS or invoicing.

8.3 Back pressure calculation for the LTM

Flow and pressure information is stamped on the nameplate located on the outside of the meter.

- Back pressure at the outlet of the turbine meter must be sufficient for accurate operation.
- Consider the following equation when determining back pressure for the turbine meter.

$$P_b \geq 2 \Delta p + 1.25p_e$$

P_b Minimum back pressure, pounds per square inch gauge (psig)

Δp Pressure drop through the meter at the maximum operating flow rate for the liquid being measured, pounds per square inch (psi).

P_e Equilibrium vapor pressure of the liquid at the operating temperature, pounds per square inch absolute (psia), gauge pressure plus atmospheric pressure.

- Open valves slowly to prevent system shock.
- Protect the Series 1500 housing and components from external impact of any kind. Note temperature limitations when selecting turbine meter location.

Important

Always use a flushing medium that is compatible with the metallurgy of the meter, internal components. Using water as a flushing medium may result in damage to the internal components of the turbine meter.

8.4 LME remote operation

Note

LME should be remote mounted when the ambient temperature is above 60 °C (140 °F).

The primary output is a single or dual high resolution signal that is amplified and shaped by an integral amplifier mounted within an explosion-proof housing. This wave pulse can be fed directly to remote totalizing counters, digital readout devices, presets, or control instrumentation.

NOTICE

Inspect all electrical connections to ensure compliance to electrical codes and safety regulations.

Part IV

Maintain

9 Planned maintenance

9.1 Maintenance considerations

Read and understand all instructions and operating procedures before performing maintenance procedure, internal component inspections or field requirement changes.

To ensure safe and accurate performance, only informed and trained personnel should install, operate, repair and maintain this product.

Important

Follow the disassembly and the assembly procedure for internal component inspection or field requirement changes.

Follow the recommendations below before servicing the turbine meter:

- Label all parts or place parts in labeled containers during disassembly.
- Do not use metal clamping devices in direct contact with any turbine meter part or surface.
- Rotor blades determine accurate flow measurement and should be handled with extreme care. Bending or altering the blades in any way can affect turbine meter accuracy.

9.2 Tools required for mechanical components

The turbine meter requires a set of tools for assembly or disassembly.

Flange installation tools

Follow all best practice procedures when installing or removing flanges.

Internal component tools

Use the following tools for turbine meter disassembly:

- Needle nose pliers
- Torque wrench (dependant on size)
- Ratchet with correspondent hex socket (dependant on size), or screwdriver with hexagonal tip
- 3 mm Allen key
- 3.5 mm flathead screwdriver
- Mallet

9.3 Prepare for mechanical disassembly

Protect the rotor blades from rough handling. Blade position is critical to turbine meter performance. Before removing the turbine meter from the system, consider the following precautions.

Prerequisites

WARNING

EQUIPMENT HANDLING AND OPERATING HAZARD

Wear personal protective equipment appropriate to the situation when working with the turbine meter. Adhere to all safety standards and best practices for operating the equipment.

Failure to comply may result in death or serious injury.

WARNING

PRESSURE HAZARD

The turbine meter is subject to pressurized fluids. Depressurize the turbine meter before disassembly.

Failure to comply may cause high pressure fluids to leak, resulting in death or serious injury.

WARNING

VOLTAGE HAZARD

Disconnect equipment from power before opening the LME and/or RME. Do not open them while power is on and an explosive gas atmosphere is present.

Failure to comply may result in death or serious injury.

Procedure

1. Disconnect all power to the turbine meter and vent all line pressure.
2. Remove security wire.
3. Remove screws and top cover of the LME.
4. Disconnect wire connections from the LME.
5. Disconnect the grounding cables.
6. Disconnect conduit connections to the turbine meter.
7. Remove turbine meter from line. Refer to Lifting equipment [Lifting conditions](#), [Lifting requirements for personnel](#), and [Safety precautions using appropriately rated lifting slings](#) for instructions on lifting the turbine meter.

9.3.1 Disassemble internal meter housing components - NPS 3 through 24

Procedure

1. Remove the downstream shaft nut, simultaneously holding the upstream shaft nut to prevent the shaft from turning.

Figure 9-1: Downstream shaft nut removal

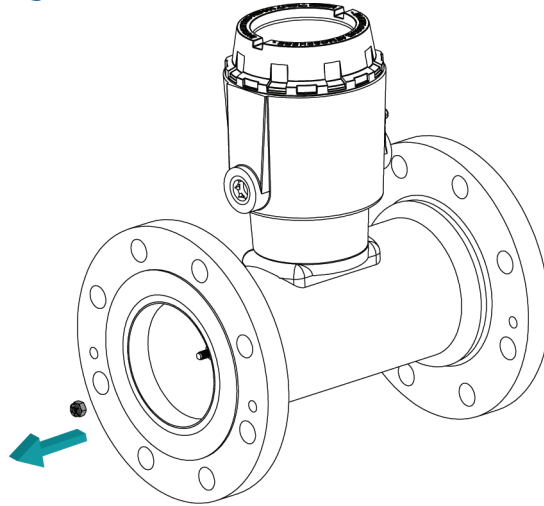

Important

The shaft nut can only be reused up to five times. Replace as needed.

2. Remove the downstream hanger assembly from the shaft.
 - a) Remove the shaft in the upstream direction to allow the insertion of a pin into the hole in the downstream hanger hub.
 - b) Push the shaft back against the pin and tap the shaft lightly to free the downstream hanger assembly.

Figure 9-2: Downstream hanger assembly removal

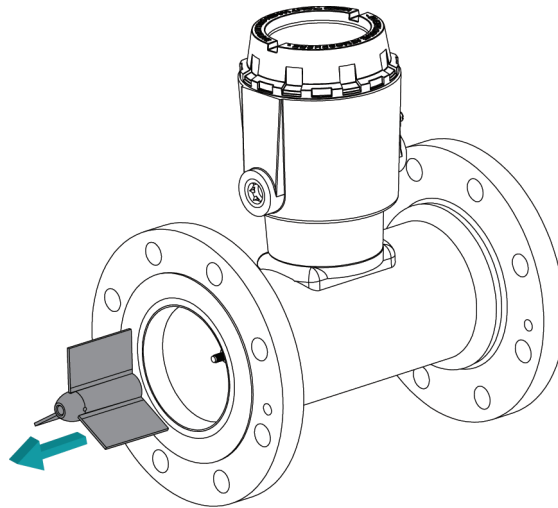

-
3. Remove the downstream cone from the shaft. The thrust washer should remain in the cone.

Figure 9-3: Downstream cone removal

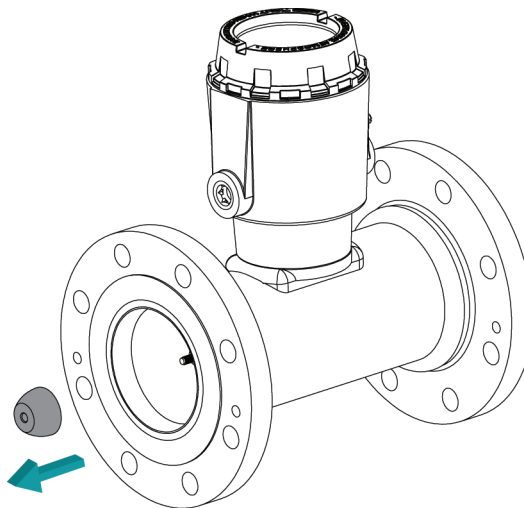

-
4. Remove the rotor from the shaft.
Depending on the turbine meter option, the rotor could be just a blade type or a rim type. The rim is not removable from the rotor assembly.

Figure 9-4: Rotor removal

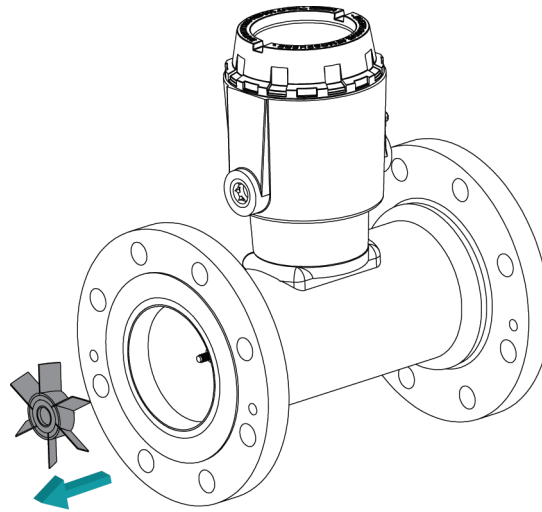

-
5. Remove the journal bearing.

Figure 9-5: Journal bearing removal

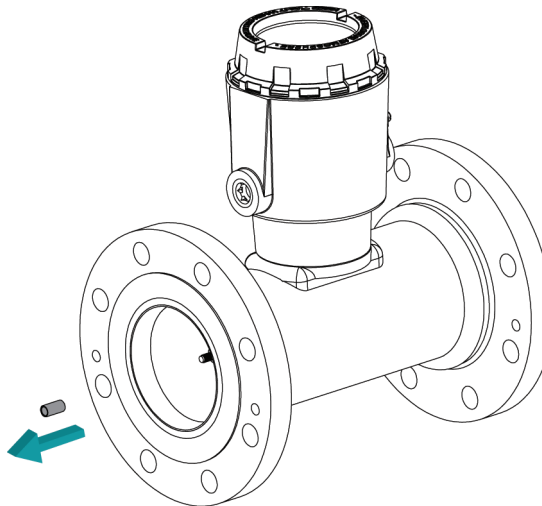

-
6. Remove the upstream cone from the shaft. The thrust washer should remain in the cone.

Figure 9-6: Upstream cone removal

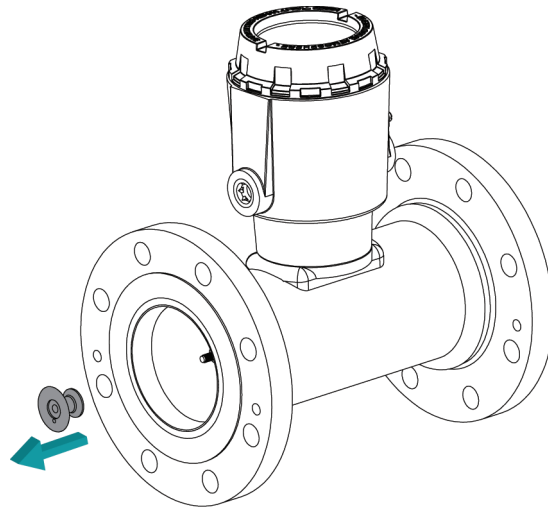

7. Remove the upstream hanger assembly from the opposite end.
 - a) To do this you must insert a pin into the hole in the upstream hanger hub.
 - b) Insert the shaft from the downstream end and push the shaft against the pin.
 - c) Tap the shaft lightly to free the downstream hanger assembly.

Figure 9-7: Upstream hanger assembly removal

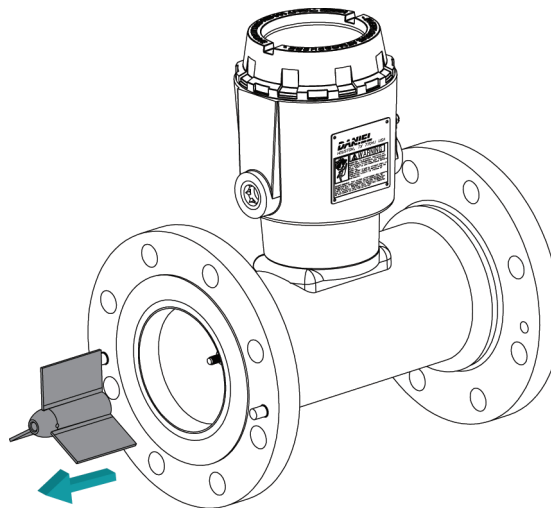

9.4 Mechanical assembly

Protection for rotor blades from rough handling as blade position is critical to turbine meter performance.

Use appropriate torque values to reinstall the shaft nut and to avoid equipment damage or inaccurate turbine meter operation.

Important

The shaft nut can only be reused up to five times. Replace as needed.

Table 9-1: Torque requirements for shaft nut reinstallation

Turbine meter size	Torque requirement
3	7.9 n-m (70 in-lbs)
4	11.3 n-m (100 in-lbs)
6	67.7-81.3 n-m (50-60 ft-lbs)
8	67.7-81.3 n-m (50-60 ft-lbs)
10	81.3-95 n-m (60-70 ft-lbs)
12	95-122 n-m (70-90 ft-lbs)
16	108-135 n-m(80-100 ft-lbs)
18	108-135 n-m (80-100 ft-lbs)
20	108-135 n-m (80-100 ft-lbs)
24	108-135 n-m (80-100 ft-lbs)

9.4.1 Assemble internal meter housing components -NPS 3 through 24

Procedure

1. Install the upstream hanger assembly in the inlet side. Secure the upstream hanger by tapping the hanger assembly with a plastic hammer.

Figure 9-8: Upstream hanger assembly installation

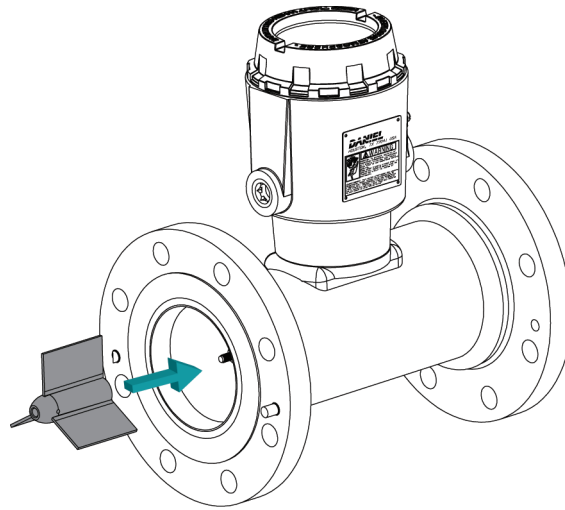

-
2. Thread the nut into the shaft end and insert the shaft through the upstream hanger assembly on the inlet side.
 3. Insert the upstream cone to the shaft. The thrust washer should remain in the cone.

Figure 9-9: Upstream cone installation

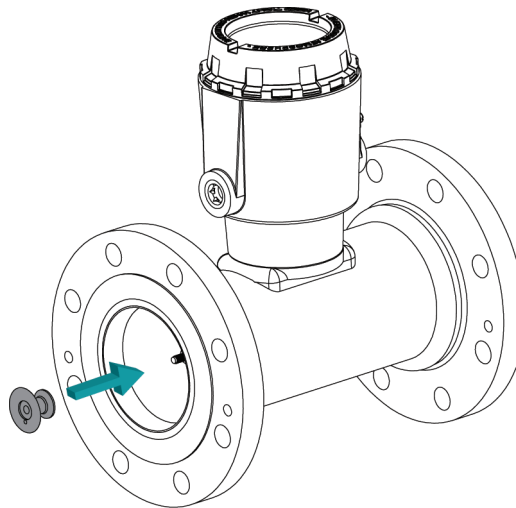

-
4. Insert the journal bearing in to the rotor assembly.

Figure 9-10: Journal bearing installation

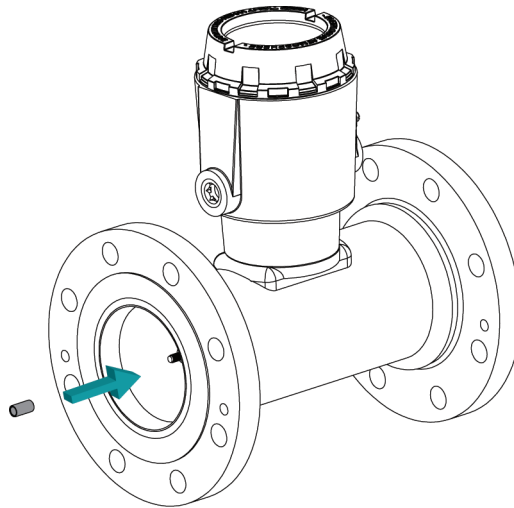

5. Install the rotor to the shaft.

Figure 9-11: Rotor installation

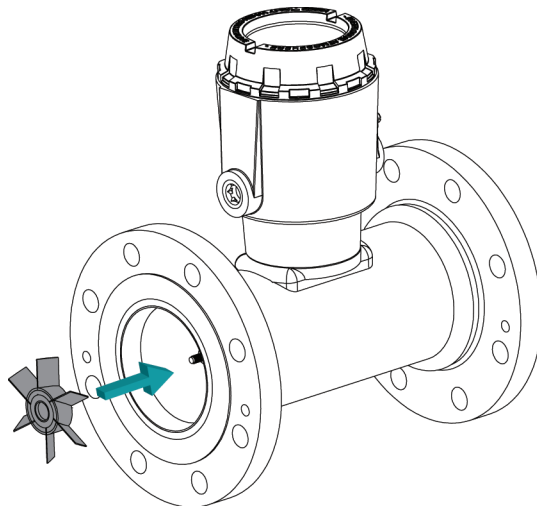

6. Install the downstream cone to the shaft. The thrust washer should remain in the cone.

Figure 9-12: Downstream cone installation

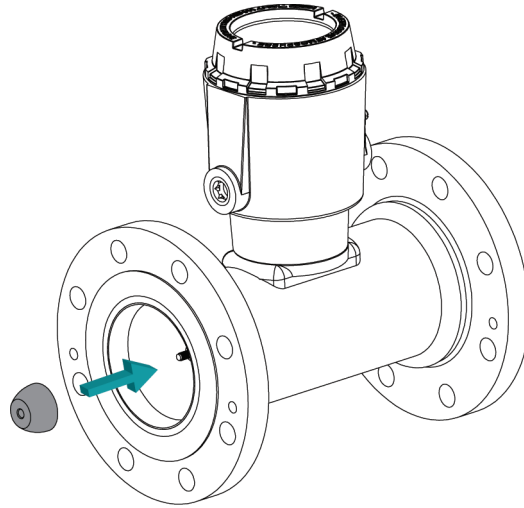

-
7. Install the downstream hanger assembly to the shaft.

Figure 9-13: Downstream hanger assembly installation

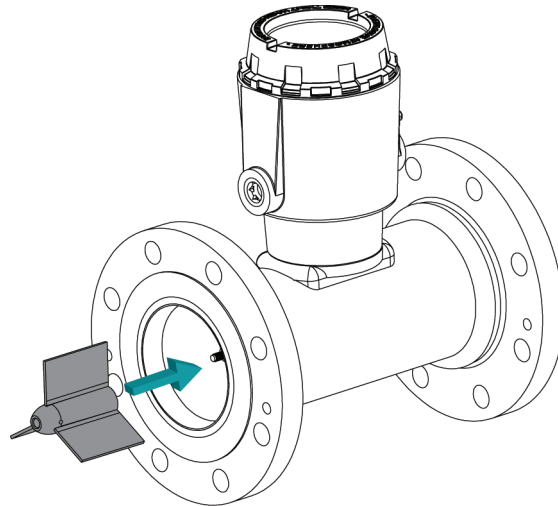

-
8. Install the downstream shaft nut, simultaneously holding the upstream shaft nut to prevent the shaft from turning.

Figure 9-14: Downstream shaft nut installation

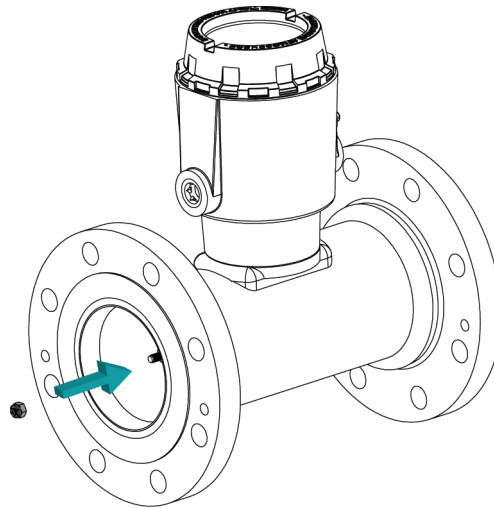

Important

The shaft nut can only be reused up to five times. Replace as needed.

9.5 Electronics enclosure disassembly

! WARNING

ELECTRONIC HAZARD

Power off the electronics after every use.

Servicing the turbine meter while powered may result in death or serious injury.

Important

Do not use a hammer to assemble the housing.

9.5.1 Disassemble the LME/RME - Standard enclosure

Procedure

1. Uninstall the security seal wire.
2. Uninstall the security wire.
3. Uninstall the security latch.
4. Uninstall the solid end cap.
5. Uninstall the wiring connections from the preamplifier.
6. Loosen and remove the socket screws from the plate bracket to the housing.
7. Loosen and remove the preamplifier socket screw to the bracket plate.
8. Loosen the grounding lugs and remove the cable.
9. Uninstall the conduit.

10. For LME only - Remove the anti-rotation bracket and pickoffs.
11. Uninstall the four socket head screws placed at the bottom of the housing.
12. Remove the housing from the flameproof pad.
13. Uninstall the O-ring from the pad.

9.5.2 Disassemble the LME - High temperature enclosure

Procedure

1. Uninstall the security seal wire.
2. Uninstall the security latch.
3. Uninstall the solid end cap.
4. Uninstall the wiring connections from the terminal block.
5. Loosen and remove the socket screws from the plate to the housing.
6. Loosen and remove the socket screws from the bracket plate.
7. Loosen the grounding lugs and remove cable.
8. Uninstall the conduit.
9. Remove the anti-rotation bracket and the pickoffs.
10. Uninstall the four socket screws placed at the bottom of the housing.
11. Remove the housing from the flameproof pad.
12. Uninstall the O-ring from the pad.

9.6 Electronics enclosure assembly



WARNING

ELECTRONIC HAZARD

Power off the electronics after every use.

Servicing the turbine meter while powered may result in death or serious injury.

Important

Do not use a hammer to assemble the housing.

NOTICE

The joint between the LME cover and housing is a threaded joint. The joint between the LME housing and Sensor housing is a spigot joint with a minimum axial length of 26.16 mm (1.030 in), radial length of 3.18 mm (0.125 in), and a clearance of 0.07 mm (0.0028 in).

9.6.1 Assemble the LME/RME - Standard enclosure

Procedure

1. Install the O-ring on the pad.

2. Install the housing on the turbine meter body or remote mounting pad. Use four screws with a torque value of 74.5 Nm (55 lbs-ft) (Capacity to be installed: each at 90°).
3. For LME only - Insert pickoffs and anti-rotation bracket.
4. Install the conduit.
5. Install the internal and external grounding cable to lug.
6. Tighten the preamplifier socket screw to the bracket plate.
7. Follow the applicable diagram for the wiring configuration. The preamplifier connectors can be removed by pulling each connector. Refer to [Interface parameters](#) for the preamplifier designator. Ensure the torque is less than 4 lbs-in.
8. Tighten the socket screws from the plate bracket to the housing.
9. Install the solid end cap.
10. Install the security seals.
11. Install the security seal wire.

9.6.2 Assemble the LME - High temperature enclosure

Procedure

1. Install the O-ring to the pad.
2. Install the housing on the turbine meter body. Use four screws with a torque value of 55 lbs-ft. (Capacity to be installed: each at 90°).
3. Insert the pickoffs and anti-rotation bracket.
4. Install the conduit.
5. Install the internal and external grounding cable to lug.
6. Tighten the terminal blocks socket screws to the bracket plate.
7. Install the pickoff cables and opt out the signal connections to the terminal blocks.
8. Tighten the socket screws from the plate to the housing.
9. Install the solid end cap.
10. Install the security seals.
11. Install the security seal wire.

9.7 Replace the preamplifier

Procedure

1. Disconnect all power to the turbine meter.
2. Remove cover of the RME.
3. Loosen screws of preamplifier bracket and lift out of the enclosure.
4. Disconnect terminal connects at TB1, TB2, and TB3.
5. Loosen screws of preamplifier and lift out.
6. Mount the replacement preamplifier board in its original position and secure using screws.

7. Attach electrical output wiring from both pickoffs to terminal connection TB2 and TB3.
8. Attach electrical output wiring from electrical accessories (conduit wiring) to terminal connection TB1, number 3 for channel A, and number 5 for channel B.
9. Secure all electrical wiring.
10. Secure screws of preamplifier bracket in to the enclosure.
11. Return cover and secure.

9.8 Planned maintenance tasks

Table 9-2: Planned maintenance tasks

Task	Recommended action
Inspect	<p>Implement a periodic inspection program to ensure all parts are free from damage due to process, ambient or other abnormal conditions.</p> <ul style="list-style-type: none"> • Internal components: rotor, upstream to downstream cone, etc. • Meter body housing, external flanges, flamepath. • Bolting • Electrical connections.
Clean	<p>Use a non-toxic metal cleaning solvent. Do not use common petrochemical solvents like Benzene, Toluene or Xylene as they can pose potential health hazards.</p>
Monitor corrosion / erosion / wear	<p>A careful review of turbine meter proving history, such as turbine meter factor control charts, can reveal potential problems with turbine meter measurements. Examples include bearing drag due to wear or an increased internal cross-sectional area due to erosion.</p>

10 Corrective maintenance

10.1 Turbine meter troubleshooting

Use the table below to troubleshoot the turbine meter. Contact the nearest Emerson service office for repairs. It is important that servicing be performed by trained and qualified service personnel.

Table 10-1: Troubleshooting

Condition	Probable cause	Correction ⁽¹⁾
No output pulses from amplifier module	Input voltage to amplifier below minimum required for operation	Apply correct voltage (10 - 30 VDC)
	Damaged or shorted pickoff (Resistance across leads should be 600-900 Ohm)	Replace pickoff
	Damaged amplifier module	Replace amplifier module
	Customer receiver unit not operating	Contact Emerson Flow customer service
	Meter rotor not turning	Troubleshoot internal assembly
Turbine meter rotor not turning	Defective rotor bearing	Return rotor assembly to factory for replacement or repair
	Rotor damaged by foreign material passing through turbine meter	Return rotor assembly to factory for replacement or repair
Inaccurate readout	Foreign material on rotor blades	Check and clean blades
	Rotor blades are bent	Return to factory for replacement or repair
	Defective accessory equipment	Troubleshoot equipment

(1) * Refer to [Prepare for mechanical disassembly](#) for disassembly procedures.

10.2 Verify the return to operational condition

After correcting maintenance issues, verify that the turbine meter is working properly by following the steps below.

Procedure

1. Inspect all electrical connections to ensure compliance with electrical codes and safety regulations.
2. Inspect all flange bolts used to secure the turbine meter in-line to ensure that correct mounting procedures are followed and that flange connections are leak-free.

3. Evaluate the system setup to ensure that all components are in the correct sequence for accurate product measurement: isolation valve, strainer, flow straightener, turbine meter, downstream section, control valve, etc.
4. Ensure that the supply voltage to the preamplifier is within the 10-30 VDC range.

11 Spare parts

11.1 Recommended spare parts

The figure below identifies the spare parts for an LME assembly.

Figure 11-1: Part identification for a standard enclosure

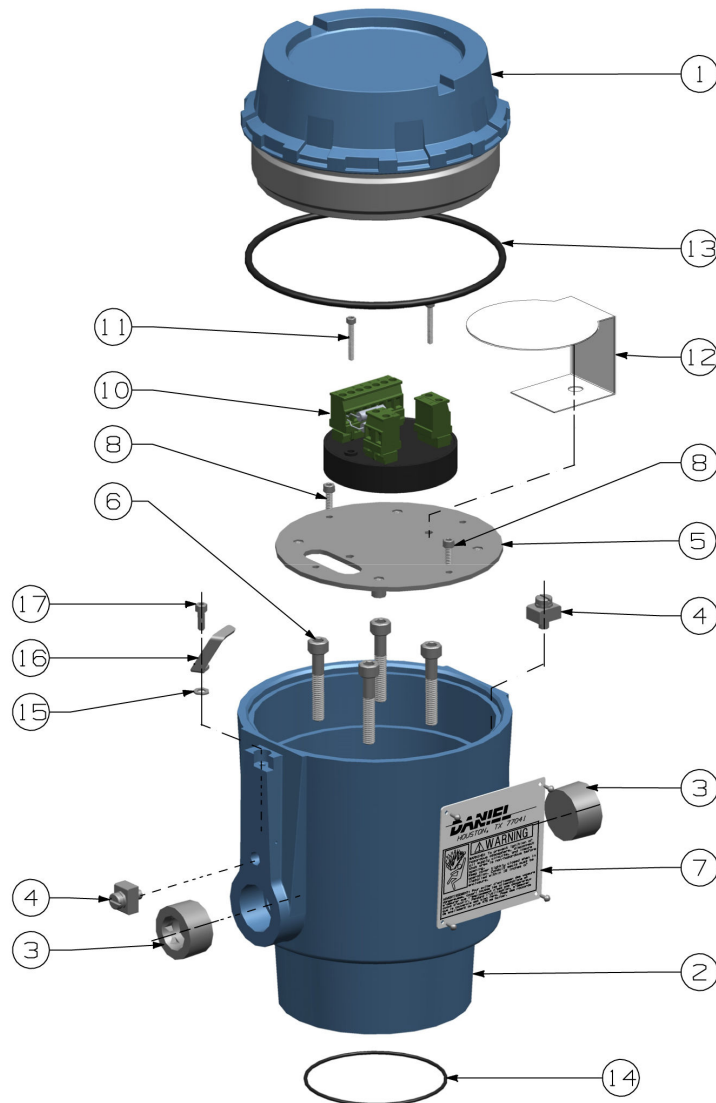

Table 11-1: Recommended spare parts for an LME assembly (standard)

Item number	Description	Part number	Quantity required
10 ⁽¹⁾	2818 Dual channel preamplifier	1-504-05-550	1
10 ⁽¹⁾	2415 Intrinsically safe preamplifier	1-504-05-449	1
10 ⁽¹⁾	1815B Zero crossing preamplifier	1-504-05-510	1
10 ⁽¹⁾	1817X Bidirectional preamplifier	1-504-05-442	1
13	O-ring FKM	2-4-9163-245	1
14	O-ring FKM	1500093-022	1
41	Pickoff	899-00-201-00	2

(1) Refer to [Interface parameters](#) for detailed preamplifier information.

Refer to [LME assembly - Standard enclosure](#), [LME assembly - High temperature](#) for other part numbers, [RME assembly - Pipe mount](#) and [RME assembly - Wall mount](#).

Order spare parts

Contact Emerson Flow customer service and provide the following information when ordering spare parts:

- Turbine meter serial number
- Part number
- Part description
- Quantity

12 Decommission the turbine meter

12.1 Shut down the turbine meter

Follow the steps below to shut down and disassemble the turbine meter for storage or shipment.



WARNING

PRESSURE HAZARD

The turbine meter is subject to pressurized fluids. Depressurize the turbine meter before disassembly.

Failure to comply may cause high pressure fluids to leak, resulting in death or serious injury.

Procedure

1. Disconnect all power to the turbine meter and vent all line pressure.
2. Remove security wire.
3. Remove screws and top cover of the LME.
4. Disconnect wire connections from LME.
5. Disconnect the grounding cables.
6. Disconnect conduit connections to the turbine meter.
7. Remove turbine meter from line. Refer to [Lifting conditions](#), [Lifting requirements for personnel](#), and [Safety precautions using appropriately rated lifting slings](#) for instructions on how to lift the turbine meter.

12.2 Turbine meter disassembly/assembly

Follow the recommendations below before disassembling the turbine meter for storage or assembling it for shipment.

- Label all parts or place parts in labeled containers during disassembly.
- Do not use metal clamping devices in direct contact with any turbine meter part or surface.
- Rotor blades determine accurate flow measurement and should be handled with extreme care. Bending or altering the blades in any way can affect turbine meter accuracy.

Thoroughly clean the turbine meter inside the housing components and store or ship as it was received. Refer to [Pack the turbine meter](#).

After the meter is shut down, refer to [Electronics enclosure disassembly](#) and [Electronics enclosure assembly](#) for the detailed disassembly/assembly procedures.

12.3 Shipment of the meter

Refer to the Emerson Flow customer service information in the preface of this document.

Emerson Automation Solutions

7070 Winchester Circle
Boulder, Colorado USA 80301
T: +1 800-522-6277
F: +1 303-530-8459
Mexico: +52 55 5809 5300
Argentina: +54 11 4837 7000
Brazil: +55 15 3413 8000
Chile: +56 2 2928 4800
Peru: +51 15190130
www.emerson.com

Emerson Automation Solutions

Central Europe: +41 41 7686 111
Eastern Europe: +41 41 7686 111
Dubai: +971 4 811 8100
Abu Dhabi: +971 2 697 2000
Austria: +43 2236 607-0
France: +33 (0) 800 917 901
Germany: +49 (0) 2173 3348 0
Italy: +39 8008 77334
The Netherlands: +31 318 495 555
Belgium: +32 2 716 77 11
Spain: 900 901 983
U.K. and Ireland: 0870 240 1978
Russian/CIS: +7 495 995 9559

Emerson Automation Solutions

Australia: (61) 3 9721 0200
China: (86) 21 2892 9000
India: (91) 22 6662 0566
Japan: (81) 3 5769 6803
South Korea: (82) 31 8034 0000
Singapore: (65) 6 363 7766

©2020 Daniel. All rights reserved. Unauthorized duplication in whole or part is prohibited. Printed in the USA.

Daniel™ ("Daniel") is an Emerson Automation Solutions brand. The Daniel name and logo are trademarks of Emerson. The Emerson logo is a trademark and service mark of Emerson Electric Co. All other trademarks are the property of their respective companies.